



Z 9 6 0 0

Project \_\_\_\_\_ Quantity \_\_\_\_\_ Length \_\_\_\_\_ Item No \_\_\_\_\_



PORTABLE  
MARKET  
Z9600

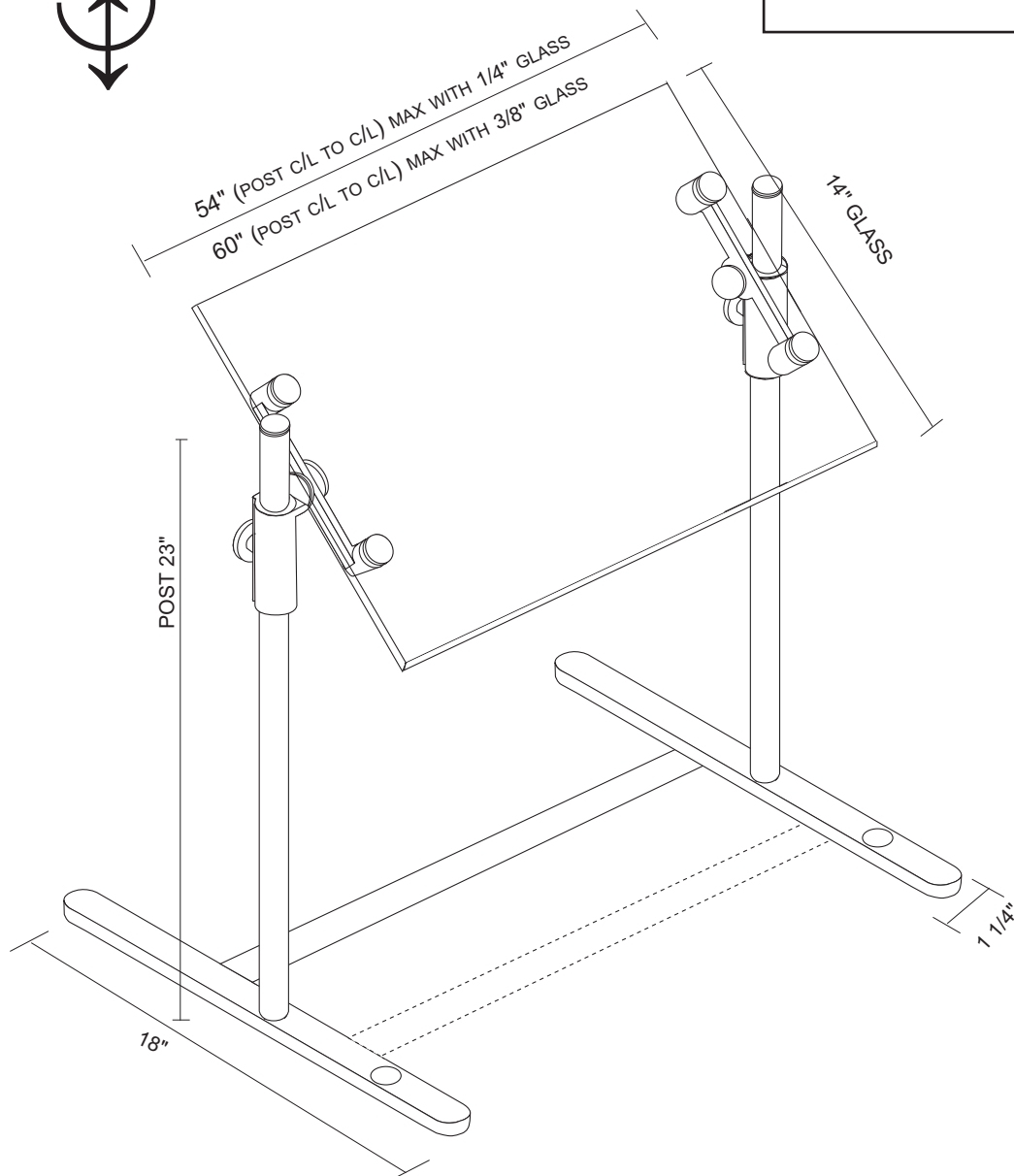

FOR A COMPLETE LIBRARY OF ISOMETRIC DRAWINGS GO TO [WWW.BRASSSMITH.COM/PROFILES](http://WWW.BRASSSMITH.COM/PROFILES)

PATENT NUMBER 6,588,863



Brass Smith, Inc.  
3880 Holly Street  
Denver CO 80207

Phone: 1-800-662-9595  
Fax: 303-331-8444  
[www.brasssmith.com](http://www.brasssmith.com)





Z 9 6 0 0

Project \_\_\_\_\_ Quantity \_\_\_\_\_ Length \_\_\_\_\_ Item No \_\_\_\_\_

<p><b>NSF LISTED FINISH OPTIONS</b></p> <p>Brushed Aluminum <input type="checkbox"/></p> <p>Black <input type="checkbox"/></p> <p>Polished Brass <input type="checkbox"/></p> <p>Polished Chrome <input type="checkbox"/></p> <p>Smoked Copper <input type="checkbox"/></p> <p><b>NSF LISTED LUSTER RAIL™ POWDER COATED FINISH OR CUSTOM COLORS</b></p> <p>Call your local sales representative for a complete list of Luster Rail™ colors or custom Color Ordering Details</p>	<p><b>OTHER OPTIONS</b></p> <p><input type="checkbox"/> End Panels</p> <p style="padding-left: 40px;"><input type="checkbox"/> Right <input type="checkbox"/> Left <input type="checkbox"/> Both</p> <p><b>GLASS OPTIONS</b></p> <p><input type="checkbox"/> 1" Radius Corner (STANDARD) <input type="checkbox"/> Square Corner</p> <p><input type="checkbox"/> 1/4" Tempered Glass (not for shelves) <input type="checkbox"/> 3/8" Tempered Glass (standard for shelves)</p>
---	---

**ITEM SPECIFICATION**

Item No.: \_\_\_\_\_

Quantity: \_\_\_\_\_

Description: Adjustable Food Shield

Model No.: Z9600

Accessories\Options\Modifications: Provide all necessary components for a fully functional, adjustable (horizontal/vertical) food guard to include:

- Overall Length (Post C/L to C/L): \_\_\_\_\_" Maximum span is post C/L to C/L: 54" (1/4" glass) or 60" (3/8" glass).

Note: Add 1 1/4" to Centerline Dimension to calculate overall length

- Glass Panel to be 1/4" thick by 14" wide.

Consult factory for custom glass.

- Glass Corners to be \_\_\_\_ Standard: 1" radius or square

Consult factory for custom glass corners.

- Finish to be \_\_\_\_\_.
- 1/4" thick glass end panel on \_\_\_\_\_ end(s). (Define: Left, Right or Both)

**CONSULT FACTORY FOR ADDITIONAL CUSTOM MODIFICATIONS AT 1-800-662-9595.**

For complete General Food Shield Performance Specifications see the *General Specification* page of this manual or go to [WWW.BRASSSMITH.COM/GENSPEC.HTM](http://WWW.BRASSSMITH.COM/GENSPEC.HTM)

Design subject to change without notice

PATENT NUMBER 6,588,863  
PRINTED 3.15.04



Brass Smith, Inc. PH: 1-800-662-9595  
3880 Holly Street Fax: 303-331-8444  
Denver CO 80207 brasssmith.com

