

Majestic HEAVY DUTY OVENS

American Range presents a new series of heavy duty majestic convection ovens. All stainless steel exterior construction for robust durability. Unique oven cavity baffle system provides maximum efficiency. Large size oven cavity is designed to accommodate full size sheet pans front to back or side to side. 5 racks with 12 positions allow for maximum capacity along with enhanced flexibility. S.S. burners w/ 75,000 & 90,000 BTU/hr. provide rapid heat and recovery. Two 40 watt oven lights provide improved visibility of the interior. Designed and built to provide superior performance and durability.



M-1-GG



STANDARD FEATURES

- 3/4" gas connection.
- All stainless steel front, sides and top.
- 50/50 double door, swings open 135°.
- Stainless steel, air-tight, door gaskets.
- 75,000 & 90,000 BTU/hr. total heat input per oven
- M-Series cavity width and depth will accommodate full size sheet pans, front to back or side to side.
- 5 chrome racks with 12 position chrome rack guides.
- Pull-out control panel for easy access to control system.

OPTIONS

- Draft hood.
- Stacking kit for double oven.
- Cook-N-hold computer control.
- Single or double door glass window.
- Heavy duty swivel casters, 5" wheel.
- 208/240 V motor and/or transformer.

MAJESTIC HEAVY DUTY MAJESTIC OVEN

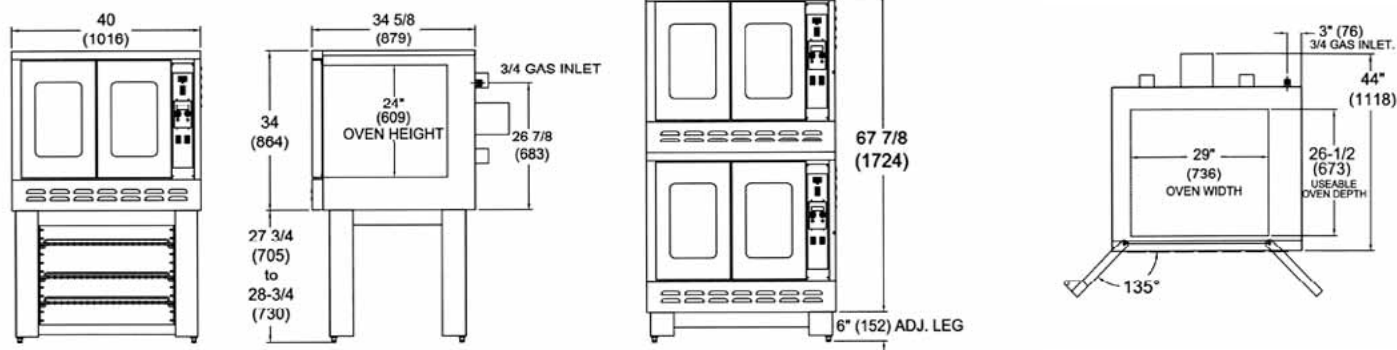

MAJESTIC HEAVY DUTY BAKERY DEPTH

MODEL	WIDTH	DEPTH	HEIGHT	BURNERS	TOTAL BTU	KW	WT. Lbs.	kg.
M-1	40"	44"	61 3/4"	2	90,000	26.38	580	26
MA-1	40"	44"	61 3/4"	2	90,000	26.38	580	26
M-2	40"	44"	68 1/8"	4	180,000	52.75	1100	499
MA-2	40"	44"	68 1/8"	4	180,000	52.75	1100	499
MA-3	40"	44"	68 1/8"	4	180,000	52.25	1100	499

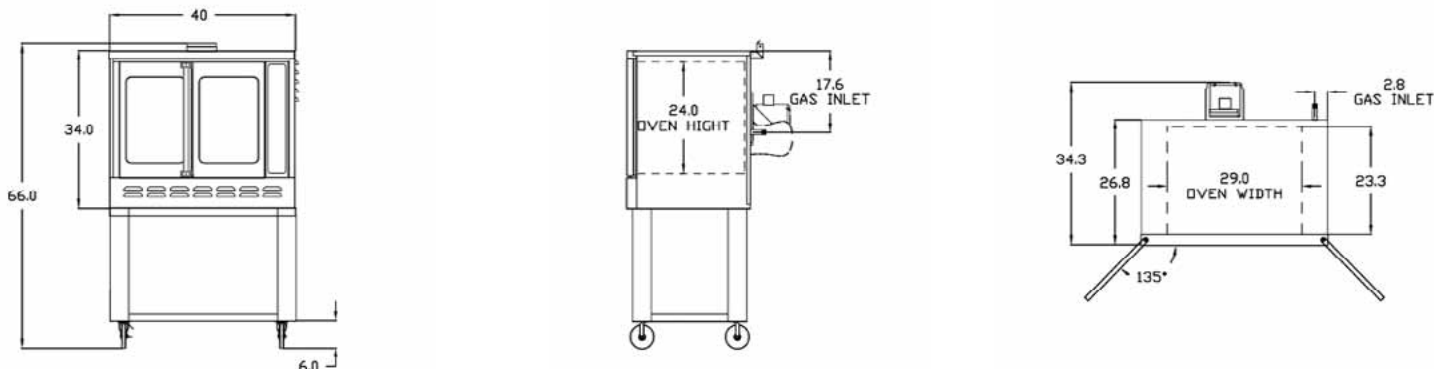

MAJESTIC HEAVY DUTY STANDARD DEPTH

MODEL	WIDTH	DEPTH	HEIGHT	BURNERS	TOTAL BTU	KW	WT. Lbs.	kg.
MSD-1	40"	34.3"	61 3/4"	2	75,000	26.38	570	25.5

STANDARD FEATURE

- All stainless steel front, sides and top.
- 50/50 double door, swings open 135°.
- Stainless steel, air-tight, door gaskets.
- 75,000 & 90,000 BTU/hr. total heat input per oven.
- 3/4" gas connection.
- 5 chrome racks with 12 position chrome rack guides,
- Pull-out control panel for easy access to control system.
- Cavity width and depth will accommodate full size sheet pan, front to back or side to side
- Oven interior with removable baffle makes cleaning the interior very easy.
- Non-mercury, direct spark ignition for convenience in start-up, durability and maintenance.
- Engineered to reduce energy costs and improve performance, reliability and serviceability.
- 2 speed 1/2" H.P. motor, 1725/1140 rpm, 120 VAC, 1ph 60 Hz, 9 amp max.
- Cook and cool down feature
- Burner "ON" light.

- Manual timer (2hrs.)
- Thermostat control-150-500F.
- Electronic ignition with 100% safety.
- Provided with 6 foot, 3 prong grounded power cord.

OPTIONS

- Single or double door glass window.
- Stacking kit for double oven.
- Cook-N-hold computer control.
- Draft hood.
- 208/240 V motor and/or transformer.
- Heavy duty swivel casters.

OPERATING GAS PRESSURE

Manifold pressure is 5.0" W.C. for natural gas or 10.0" W.C. for propane gas. Specify type of gas and altitude if over 2000 feet. 3/4" NPT Gas inlet.

CLEARANCES

For use only on non-combustible floors. Legs or casters are required, or 2" (51) overhang is required when curb mounted. Clearance from non-combustible walls is 0". When unit is placed next to combustible walls, clearances must exceed 12" (305) on sides, and 4" (102) from rear. Radiant broilers for non-combustible locations only! American Range is a quality manufacturer of commercial cooking equipment. Due to continuing product improvements, these specifications are subject to change without prior notice.

