



Item No. \_\_\_\_\_

Project \_\_\_\_\_

Quantity \_\_\_\_\_

### 30" Electric Range with Convection Oven Base

### Model: R30C Series



Model R30C-APD shown

#### SHORT/BID SPECIFICATION

Range shall be a **LANG Manufacturing Model R30C**\_\_\_\_ [Specify one]:

- APA**, with 4 ea. 8" diameter French Plates;
- APB**, with 1 ea. 12" x 24" x 1/4" thick Hot Plate and 2 ea. 8" diameter French Plates;
- APC**, with 2 ea. 12" x 24" x 3/4" thick Hot Plate;
- APD**, with 18" wide Griddle and 2 ea. 8" diameter French Plates;
- APE** with 18" wide Griddle and 1 ea. 12" x 24" x 3/4" thick Hot Plate;

A 30" wide heavy duty electric heated unit with five half size pan capacity convection oven base and 15.6-16.8-kW total power input; all stainless steel exterior; fully insulated oven with stainless steel interior, heavy duty door hinged left, with double pane viewing window and five chrome plated oven rack standard; choice of: -AP [solid state knob-set] or -PT [touch-pad programmable] oven controls, with individual cook-top component controls; plus all the features listed and options/accessories checked:

#### STANDARD PRODUCT WARRANTY

- One year, parts & labor
- Lifetime warranty on oven door mechanism

#### CONSTRUCTION FEATURES

- One piece heavy duty 430 Series stainless steel exterior, with attractive No. 4 finish
- Cooking compartment is 430 Series stainless steel
- 2" insulation on six sides of cooking compartment
- Heavy duty compartment door, with large double pane tempered glass window
- Powerful blower centered on side of compartment
- Nine position oven rack slide supports
- Five chrome-plated oven racks provided
- 4" swivel casters standard
- 1" high range-top back stop
- 2-3/4" wide full width front grease trough
- Grease drain in trough with full width & depth spillage drawers
- Griddle configurations include a one piece splash guard, back & sides

#### PERFORMANCE FEATURES

- Compact 30" wide range incorporates half-size convection oven with five 13 X 18" pan capacity
- 150 to 450 F oven operating temperature range
- Solid state oven temperature control accurate to 4 F
- Two speed fan with fan pulse capability
- Door interlock switch cuts power to fan
- Choice of cook top configurations, to include:
  - 4 ea. 8" diameter French Plates
  - 2 ea. 8" diameter French Plates and 1 ea. 12" wide Hot Top
  - 2 ea. 12" wide Hot Tops
  - 18" wide 1/2" thick Griddle and 2 ea. 8" diameter French Plates
  - 18" wide 1/2" thick Griddle and 1 ea. 12" wide Hot Plate
- Full front grease trough, grease drain & spillage drawers speed cleanup
- Separate, independent controls allows simultaneous multi-function cooking

#### CONTROLS [For Oven] CHOICE OF:

- Accu-Plus™ Control [-AP]**
  - Simple knob-set time and temperature controls
  - 1-hour timer with non-stop buzzer
  - Pulse-fan switch
  - HIGH-LOW speed fan switch
  - Power-ON switch
- Platinum Control [-PT]**
  - Solid state, icon driven, one-touch programmable controls
  - Up to 99 product programs, with multiple baking tiers
  - Time, temperature, heat loss and adjustable shelf compensation
  - Cook-n-Hold programming
  - 2-speed fan & variable-rate pulse-fan control
  - PC link programming
  - Power-ON switch
- Range controls vary by top configuration and will include:**
  - [-APA] Four 6-heat level switches [ea. French Plate]
  - [-APB] One thermostat for Hot Plate & Two 6-heat level switches [ea. French Plate]
  - [-APC] Two thermostats, one for each Hot Plate
  - [-APD] One thermostat for 18" Griddle & two 6-heat level switches [ea. French Plate]
  - [-APE] One thermostat for 18" Griddle & one thermostat for the Hot Plate







Sheet No. LSP-R8 (rev. 06/07)

# 30" Electric Range with Convection Oven Base

# Model: R30C Series

## CONFIGURATION GUIDE

Model Has:	R30C-APA	R30C-APB	R30C-APC	R30C-APD	R30C-APE
Oven Base:	Convection	Convection	Convection	Convection	Convection
Griddle:	-	-	-	18" wide	18" wide
French Plates:	4 each	2 each	-	2 each	
Hot Plates:	-	1 each	2 each		1 each
Pictogram: [Unit Top View]					

## INSTALLATION REQUIREMENTS

- Unit is shipped in one piece
- Ⓔ Single 208/240V, 1/ 3-Phase; or 480V, 3-phase electrical connection
- Installation under approved vent hood required. Consult local codes. [Power connection from bottom. See below]

## OPTIONS & ACCESSORIES

- Grooving on [1" thick ONLY] Range Griddle Plate
- 480 Volt, 3-phase model
- Extra wire pan rack [Five provided as std.]

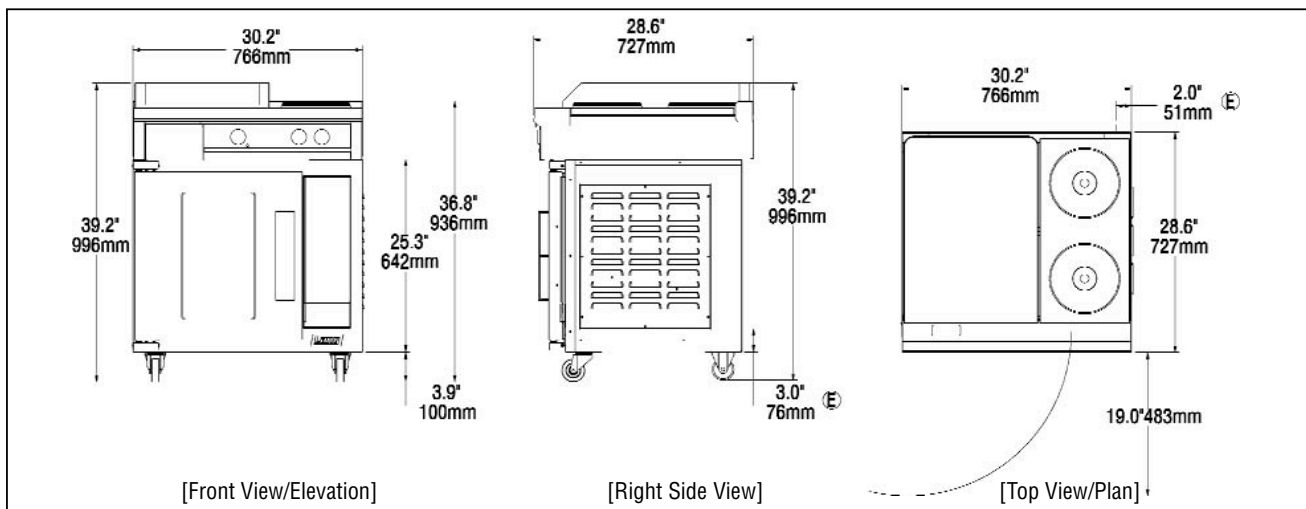

Model	Height x Width x Depth (With standard legs)	Clearance from combustible surface	Weight		Freight Class
			Actual	Shipping	
R30C_	32" x 30.2" x 30" 812.8mm x 766mm x 762mm	Sides: 3" (77mm) Back: 3" (77mm)	362* lbs. 165 kg	412* lbs. 187 kg	85

\* Depending on configuration.

Model	Ⓔ Electrical Requirements			
	Voltage	Total kW	Phase	Amps/Line
R30C_	208V/60Hz	19.8	1	95.2
	240V/60Hz	19.8	1	82.5
	208V/60Hz	19.8	3	57.6
	240V/60Hz	19.8	3	50.0
	480V/60Hz	19.8	3	25.0

## CAD SYMBOLS & PRICING



Due to continuous improvements, specifications subject to change without notice.



Sheet No. LSP-RS (rev. 06/07)

**LANG MANUFACTURING - A DIVISION OF STAR MANUFACTURING INT'L, INC. • 10 SUNNEN DR. ST. LOUIS, MO 63143**  
**TOLL FREE: 800.264-7827 • FAX: 314-781-3636 • www.langworld.com**