



"Your Solutions Partner"

Specifications

F.O.B. Sedalia, Missouri 65301



E304SW

OPTIONS:

- 3-phase wiring
- 1000 watt elements
- Stainless steel heat compartment liner - **FMOD-SS-LINER**
- Hardwood cutting board in lieu of poly
- Stainless steel cutting board in lieu of poly
- Drop type brackets for cutting board
- Casters - **EPxxx**
- Stainless steel feet - **SS-FEET**
- Serving shelves - **656-xS/656-460-xS/956-xS/956-460-xS**
- Glass display shelves - **98x**
- Shelves/Carving boards - **441-xS/442-xS/445-xS**
- Buffet shelves - **63x/73xFL/73xBL/73xHT/83x/93xFL/83xBL/93xHT**
- Adapter plates - **31, 32, 33**
- Insets/Inset Covers - **521, 522, 523**
- Telescope covers - **546, 548**
- Tubular tray slides - **3BTS-FX-x/HD-x**
- Spillage pans - **576, 676**

AGENCY LISTINGS:



DUKE MANUFACTURING CO.
2305 N. Broadway
St. Louis, MO 63102

800.735.3853 Toll Free
314.231.1130 In Missouri
314.231.5074 Fax
www.dukemfg.com

Approval Stamp(s):

PROJECT INFORMATION:

PROJECT: _____
ITEM: _____
QUANTITY: _____

MODEL:

Aerohot Steamtables Hot Food Units - Electric - Sealed Wells

- E302SW/EP302SW** 2 top openings
- E303SW/EP303SW** 3 top openings
- E304SW/EP304SW** 4 top openings
- E305SW/EP305SW** 5 top openings

TOP:

- 20 gauge, 300 Series stainless steel
- Die-stamped openings - 12" x 20"
- Poly carving board - 7"W x 1/2" thick with 18 gauge stainless steel support base and die-stamped brackets

HEAT COMPARTMENTS:

- Stainless steel die-formed 6-1/2" deep sealed well
- Individual well drains and drain valves
- Wet or dry use
- Single phase standard

BODY, UNDERSHELF AND LEGS:

- 20 gauge, 430 Series stainless steel body
- 18 gauge, 430 Series stainless steel undershelf
- 430 Series stainless steel tubular legs with adjustable plastic feet

ELECTRICAL INFORMATION:

- 750 watt element under each compartment
- Wired to operate on 120, 208 or 240 volt
- Single or three phase
- AC current
- Each section with infinite switch
- Permanently wired, 6' long cord with plug provided

SHORT FORM SPECIFICATIONS:

Duke Aerohot Steamtables - Hot Food - Electric - Sealed Wells. Top shall be heavy gauge, 300 Series stainless steel, with body, undershelf and legs formed of heavy gauge 430 Series stainless steel. Top to have die-stamped openings measuring 12-1/16" x 20-1/16", with 6-1/2" deep sealed well with 1/2" drain. Single phase standard. Each compartment to have 750 watt element fitted under warming compartment. Each sealed hot food well to have individual drain valve. Wired to operate on 120, 208 or 240 volt, single or 3-phase. AC current, as ordered. Each section to be controlled by infinite switch. Permanently wired, 6' long cord with plug provided. Units to be furnished with poly carbonate carving board measuring 7" x 1/2" thick with 18 gauge stainless steel support base and die-stamped brackets. Portable units to have NSF listed casters, 5" diameter, rubber, swivel-type, two with locks, all non-marking tires, with 9"L pusher bar attached to end panel on operator's right.

"P" - prefix on model number denotes portable unit.



**AEROHOT STEAMTABLES
HOT FOOD UNITS - ELECTRIC - SEALED WELLS**

- E302SW/EP302SW** 2 top openings
- E303SW/EP303SW** 3 top openings
- E304SW/EP304SW** 4 top openings
- E305SW/EP305SW** 5 top openings

A.I.A. File No. 35-C-13

Catalog No. AFS-ELECSW

AEROHOT STEAMTABLES - HOT FOOD UNITS - ELECTRIC - SEALED WELLS

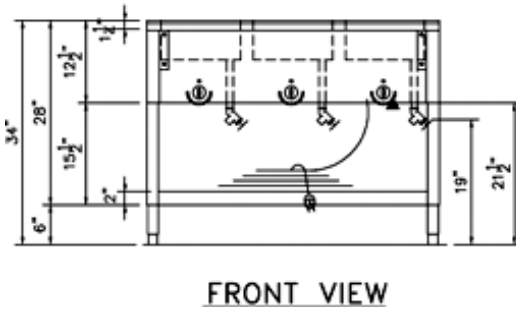
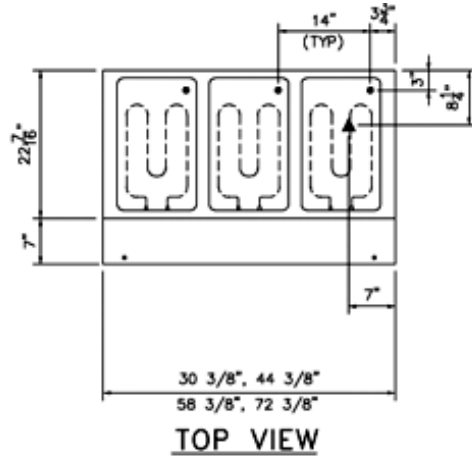

LEGEND	
▲	ELECTRICAL CONNECTION
"P" = prefix on model number denotes portable unit	

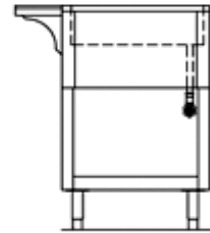

DIMENSIONS: (Consult factory for 3-phase electrical requirements and other options.)

Freight Class: 85

Model	Length		Width		Height		Top Openings	Cube ft. crated	Weight	
	in.	cm	in.	cm	in.	cm			lbs.	kg
E302/EP302	30-3/8	77.2	22-7/16	57.1	34	86.4	2	23.4	81/90	36.8/40.9
E303/EP303	44-3/8	112.8	22-7/16	57.1	34	86.4	3	32.5	107/114	48.6/51.8
E304/EP304	58-3/8	148.3	22-7/16	57.1	34	86.4	4	41.5	138/144	62.7/65.5
E305/EP305	72-3/8	183.9	22-7/16	57.1	34	86.4	5	50.5	165/172	75.0/78.2

ELECTRICAL SPECIFICATIONS:

Model	120 Volt - 750 watt elements			208 Volt - 750 watt elements			240 Volt - 750 watt elements		
	Watts	Amps	NEMA	Watts	Amps	NEMA	Watts	Amps	NEMA
E302/EP302	1500	12.5	5-15	1500	7.2	6-20	1500	6.3	6-20
E303/EP303	2250	18.8	L5-30	2250	10.8	6-20	2250	9.4	6-20
E304/EP304	3000	25.0	5-50	3000	14.4	6-20	3000	12.5	6-20
E305/EP305	3750	31.3	5-50	3750	18.0	L6-30	3750	15.6	6-20

Cord and NEMA plug included.



"Your Solutions Partner"

DUKE MANUFACTURING CO.
2305 N. Broadway
St. Louis, MO 63102

800.735.3853 Toll Free
314.231.1130 In Missouri
314.231.5074 Fax
www.dukemfg.com