

Panasonic

STEAMERS

Connectionless Steamer

NE-2180

Powered by
Microwave Technology

**SONIC
STEAMER®**



**SONIC
STEAMER®**

- 2100 Watts* of cooking power
- Holds two full-size 4" tall steam table pans with covers
- Top and bottom energy feed with 4 magnetrons (Heating elements)
- "Grab & Go" door handle

Ideal for heavy volume steaming and microwave applications in restaurants, supermarkets, delicatessens, school food service, health care and banquet catering

* I.E.C. 705-83 Test Procedure



<http://www.panasonic.com/cmo>

Pro



NE-1021



NE-1051



NE-1056

Pro I



NE-1257/NE-1258



NE-1757



NE-2157

SONIC STEAMER



NE-2180



NE-3280



SONIC STEAMER



Steaming Rack Available

- 2100 Watts* of power
- 4 magnetrons (heating elements)
- Top and bottom energy feed
- Large oven capacity: 1.6 ft³
- Holds two 4" tall, full-size steam table pans with covers
- Chef technical support
- 8 programmable memory pads
- 16 memory capability
- Shift key (AM-PM)
- Programmable or dial timer
- 3-stage cooking
- 5 power levels
- Drop down counter style door
- Self diagnostics
- Digital display
- Program list/Cycle counter
- Removable center shelf
- Tone control
- Stainless steel cabinet & cavity
- Easy to clean air filters
- See-through oven door
- Easy to change interior oven light

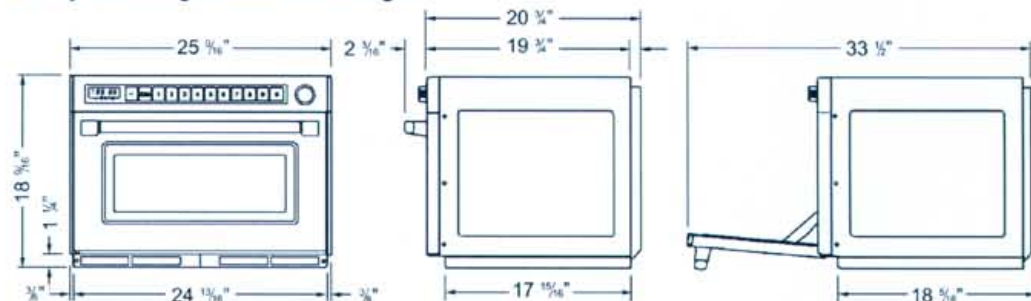

NE-2180

2100 Watt* Commercial Microwave Oven

Technical Specifications

Power source: 208/230-240 V, 60 Hz, Single phase

Receptacle required: 30 Amp, NEMA 6-30R 

Frequency: 2,450MHz

Required power: 208V (20.0A) 230-240V (18.0A)

Output*: 2100 watts

Outer dimensions: 25 3/16" w x 20 3/8" d x 18 3/8" h

Cavity dimensions: 21 3/8" w x 13" d x 9 1/2" h

Net weight: 117 lbs.

Shipping weight: 128 lbs.

Shipping box size: 29 7/8" w x 26 1/2" d x 22 1/2" h, 9.9 ft³

Timer: Maximum times for each stage of cooking

— Hi and Med. power=15 minutes

— Low, Defrost and Hold power=60 minutes

Memory capability: 16 programs

To specify a Panasonic Connectionless Steamer:

The NE-2180 Commercial Microwave Oven meets or exceeds all safety performance and sanitation standards set for commercial food service microwave ovens by: UL, HHS, FCC and NSF.

Plus, oven shall have output power 2100 Watts*, equipped with four magnetrons, top and bottom energy feed, able to accommodate two 4" tall full-size pans, drop down counter style door, Grab & Go door handle, removable center shelf, 8 programmable pads, 16 memory, shift key (AM-PM), 3-stage cooking, 5 power levels (HI, MED., LOW, DEF., HOLD), programmable lock, cycle counter, tone control, self diagnostics, dial timer to select cooking time, video training and Chef/Test kitchen technical support.

* I.E.C. 705-88 Test Procedure. Specifications subject to change without notice.

Panasonic

Panasonic Home and Commercial Products Company
Commercial Foodservice Division
One Panasonic Way, Panazip 4A-4, Secaucus, NJ 07094
TEL: (201) 348-5377 FAX: (800) 553-0384
<http://www.panasonic.com/cmo>