

**EM-60 63 Qt.
Planetary Mixer**

ITEM # _____

MODEL # _____

PROJECT NAME # _____

SIS # _____

AIA # _____



**EM-60 63 Qt.
Planetary Mixer**

- 601434 (EM60)** 63 Qt. Floor Model Planetary Mixer 208 V/1p/60Hz
- 601435 (EM603)** 63 Qt. Floor Model Planetary Mixer 208 V/3p/60Hz

Short Form Specification

Item No. _____

Unit to be Electrolux-Dito 63 Qt. Planetary Mixer with features that include: Stainless steel bowl. One-piece alloy head containing the self-lubricating planetary gears and the transmission. Powerful motor with mechanical speed variation with 8 speeds. A single lever is used to raise and lower the bowl. A safety device will automatically stop the machine when the bowl is lowered. Supplied with 3 tools: Beater, Dough Hook and Whisk.

Main features

- Power: 3 HP—Single phase and Three phase.
- Variable speed: 25-160 rpm.
- 2.2 kW.
- Red OFF, Green ON Buttons, and Timer
- Compact Design
- 8 speeds that permit exceptional results.
- The “V” belt speed variator protects the mechanism and the motor against incorrect use.
- Stainless steel bowl - 63 Qt. capacities.
- Raising and lowering of the bowl controlled by lever with an automatic locking of the bowl when in the raised position.
- Safety device will automatically stop the machine when the bowl is lowered.
- Powerful motor with high start-up torque.
- Planetary gearing with self-lubricating gears eliminating any risk of leaks.
- Sturdy construction with mechanically welded strong metal frame.
- Easily disassembled accessory drive hub.
- Delivered with :
 - Beater, Dough Hook, Whire Whisk and Mixing Bowl for 63 Qt.
- Dimensions: (LxWxH): 42.5” x 27” x 56.5”
- Approx. shipping weight—838 lbs
- ETL electrical and sanitation listed/CETL (Canada).
- NEMA # : 6-20P (single phase only)
- 2 year parts warranty, 1 year labor.

Accessories

- Beater for 63 Qt. Mixer
- Dough Hook for 63 Qt. Mixer
- Wire Whisk for 63 Qt. Mixer
- Mixing Bowl for 63 Qt. Mixer

Optional Accessories

- Beater for 63 Qt. Mixer (PNC 653083)
- Dough Hook for 63 Qt. Mixer (PNC 653084)
- Wire Whisk for 63 Qt. Mixer (PNC 653086)
- Mixing Bowl for 63 Qt. Mixer (PNC 653087)
- 42 Qt. Bowl Kit with 3 Attachments (PNC 653034)
- Bowl Scraper 63 Qt. (PNC 653442)
- Trolley for 63 Qt. Mixing Bowl (PNC 653035)
- Electric Heater for 63/84 Qt. Mixers (PNC 653433)
- Gas Heater for 63/84 Qt. Mixers (PNC 653432)
- Heavy Duty Dough Hook for 63 Qt. Mixer (PNC 653481)
- Reinforced Wire Whisk for 63 Qt. (PNC 653097)
- Puree/Mashed Potato Attachment with 3 grids (PNC 653187)



NEMA #: 5-15P (single phase)
Without plug (three phase)

Approval: _____

Front View

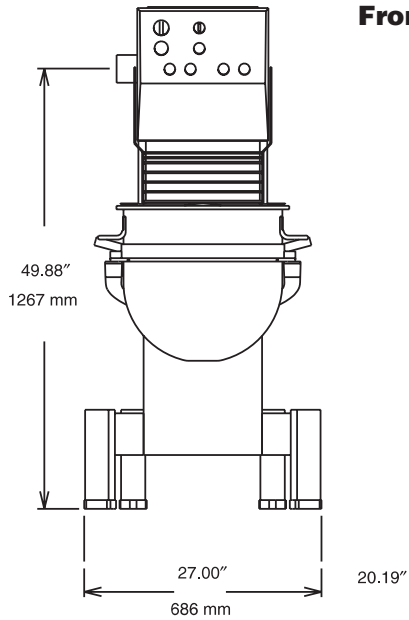

Electric

Supply voltage:

601434 (EM60)

208 V/1p/60Hz - 15.4 A

601435 (EM603)

208 V/3p/60Hz - 9.3 A

Key Information

Working capacity – lbs. of flour

Shortcrust pastry: 33

Cold water paste: 44

Sweet pastry: 33

Croissant: 40

Brioche: 40

Meat: 66

Potato Puree: 66

Top View

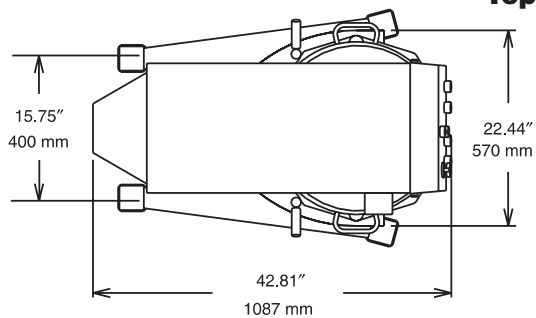

EC = Electrical connection

Side View

