

Carts & Kiosks - Bar Cart

Contact Your Vollrath Sales Representative for Custom Carts & Kiosks!

Carts & Kiosks—Bar Cart 75501

Options for canopy for bar:

- Pendant lights including 20A electrical service
- Plexiglass letters
- Custom signage

Black polyform countertops (NSF Certified) are durable and easy to clean.

Option: Base Options to match any décor

- Custom paint
- Custom laminate covered base (3 sides standard)

1" (2.5 cm) black bumper molding protects walls and prolongs life of condiment cart.



Four heavy-duty non-marking swivel casters for smooth and easy movement without leaving scuff marks- 2 swivel and 2 swivel with brakes.

Prepainted black or silver ACM constructed base and toe kick

- Lightweight and durable
- Safe for outdoor use
- Incredibly strong and allows for unique shapes

2 24" (60.9 cm) stainless steel speed rail – Single



Option: Insulate stainless steel ice bin w/drain, 45 lb. capacity, includes cover. 21.25" x 15.25"

7-1/2 gallon waste water tank

Option: Bottle opener and cap catcher

Optional Features (Not Shown)

- 15, 20, or 30 amp electrical service
- Stainless steel insulated ice bin with sliding cover (60 lb. capacity) 27" x 20" x 8" deep
- Bag-in-box system



Setting the Standard™

Carts & Kiosks - Bar Cart

75501 Bar Cart

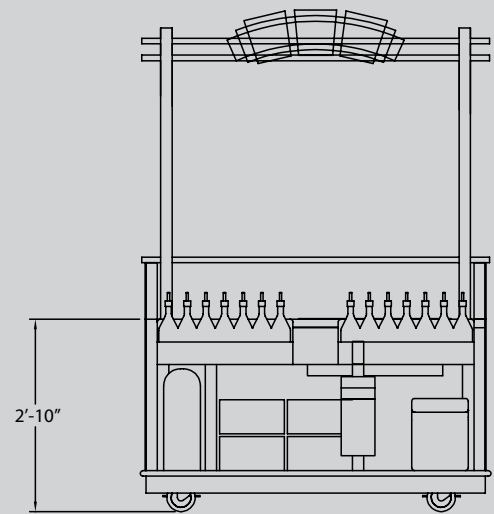
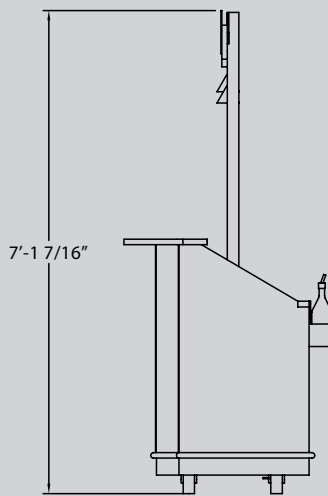
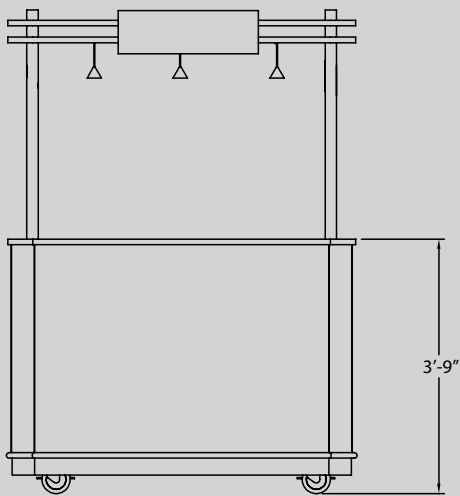
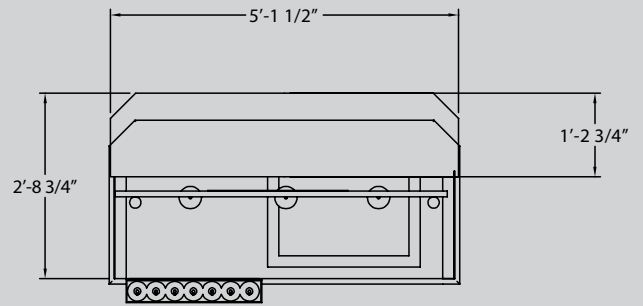

The Vollrath Company, L.L.C.
1236 North 18th Street
Sheboygan, WI 53082-0611 USA
Customer Service: 800.628.0830
Equipment Service: 800.628.0832
Main PH: 920.457.4851
Fax: 920.459.6573
Form L35624 Rev. 8/06



Setting
the *Standard*[™]