

**ANVIL**

MEAT GRINDER ELECTRIC

NO.12 & NO.22

MEAT GRINDER ELECTRIC



MIN0012



MIN0022

"Anvil's meat grinders are noted for their exceptional reliability and attractive, compact design."

APPLICATION

- IDEAL FOR BUTCHERIES, SUPERMARKETS, DELIS, AND PIZZA SHOPS
- RELIABLE UNDER THE MOST DEMANDING CONDITIONS
- ATTRACTIVE DESIGN SUITABLE FOR ANY OPEN KITCHEN OR SUPERMARKET

CONSTRUCTION

- COMPLETE STAINLESS STEEL BODY, HEAD AND TRAY
- THE No. 12 FEATURES A 3/4 HP MOTOR, ENABLING 220lbs OF MEAT TO BE GROUND PER HOUR
- THE No. 22 IS INTENDED FOR MORE HEAVY-DUTY FOOD PROCESSING APPLICATIONS. THE 1.5HP MOTOR GRINDS 440lbs OF MEAT PER HOUR
- GRINDER KNIVES AND PLATES ARE ALSO AVAILABLE AS ACCESSORIES
- STRICT COMPLIANCE WITH HYGIENE AND SAFETY STANDARDS
- ENERGY EFFICIENT MOTOR AND PRECISION GEAR DRIVE
- COMPACT SIZE; NO SHARP CORNERS OR SEAMS
- FORWARD AND REVERSE SWITCH

Anvil reserves the right, without notice, to make changes and revisions to product specifications, materials and design, which in our opinion, will provide better performance, durability and efficiency.

QUALITY  GUARANTEE

ALL ANVIL EQUIPMENT COMES WITH A ONE YEAR WARRANTY ON COMPONENTS AND DEFECTIVE WORKMANSHIP

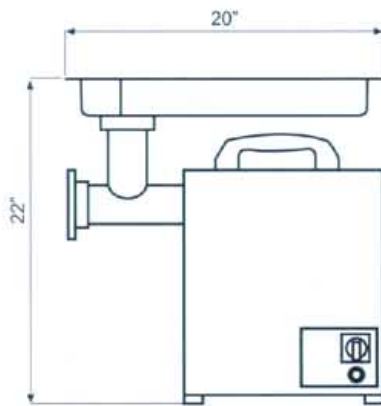
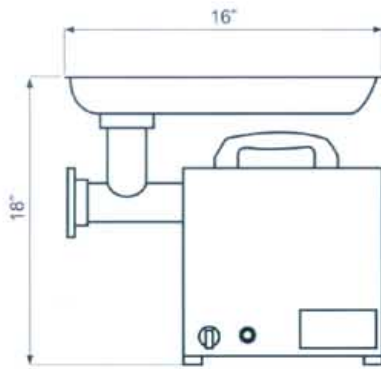

MEAT GRINDER ELECTRIC

MODELS:
MIN0012
MIN0022

NOTE:

When viewing the appliance from the front in its usual operating position, the width (W) of the product is the total distance from left to right; the depth (D) of the product is the total distance from front to back; the height (H) is the total distance from the bottom of the product to the top



GRINDER PLATES

NB: ALL ANVIL GRINDER PARTS ARE MADE OF HIGH GRADE STAINLESS STEEL



GRINDER KNIVES

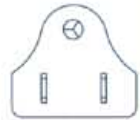

NEMA 5015P
110V

DESCRIPTION	MEAT GRINDER NO.12	MEAT GRINDER NO.22	ACCESSORY CODES	DESCRIPTION
MODELS	MIN0012	MIN0022	XMIN1206	GRINDER KNIFE NO.12
POWER (HP)	0.75	1.5	XMIN1207	GRINDER PLATE 1/8
VOLTAGE (V)	110	110	XMIN1208	GRINDER PLATE 1/4
DIMENSIONS (in) (W x D x H)	9 x 16 x 18	11 x 20 x 22	XMIN1209	GRINDER PLATE 1/2
BOX DIMNS (in) (W x D x H)	13 x 17 x 19	16 x 25 x 23	XMIN2206	GRINDER KNIFE NO.22
PRODUCTION (lbs/Hr)	220	440	XMIN2207	GRINDER PLATE 1/8
BLADE SPEED (RPM)	170	170	XMIN2208	GRINDER PLATE 1/4
WEIGHT (lbs)	66	110	XMIN2209	GRINDER PLATE 1/2

Note: Output performance figures quoted are dependant on various factors.

Manufactured by:
Scientific Engineering (Pty) Ltd
South Africa
Website: www.anvilworld.com

