



Project:

Item Number:

Quantity:

SERVEWELL® HOT FOOD TABLE



ServeWell® 3 Well Hot Food Table

DESCRIPTION

We build each ServeWell® unit with heavy-gauge steel, and engineer the body, legs, and base for strength and durability. The complete line of ServeWell® food tables are designed to eliminate the frustrations you have had with traditional food service units.

Vollrath offers the first truly innovative design in value-priced mobile serving equipment. The heart of this revolutionary line is the Hot Food Table, available in 2-, 3-, 4-, and 5-well configurations.

Each well will accept full-size or fractional pans to 6 inch (150 mm) deep, and can be used with standard adaptor plates and insets for serving flexibility.

FEATURES

- Thermoset Fiber-Reinforced Resin Wells – self-insulating and maximum energy efficiency.
- Thermoset Wells – will not rust or pit.
- Thermoset Wells – clean easily by wiping off water deposits from the non-metallic surface.
- Thermostatic Heat Controls – automatically adjust for water temperature and food volume changes to reduce food waste.
- Capillary Tube Thermostats control supply power only when needed for maximum power efficiency.
- Dome Heating Elements use up to 25% less energy and concentrate energy into the wells.
- Non-stick Surface on Elements prevent scale build-up for easy cleaning and longer operating life.
- Elements are cast-in for longer service life and greater energy transfer.
- Wide No-Drip Lips on wells keep top surface dry.
- Wells are equipped with individual brass drain valves.
- Recommend using up to 4" (10.2 cm) deep food pans – standard and fractional sizes.
- 7-1/2" wide plate shelf standard.
- 8" wide x 3/8" thick polyethylene NSF-approved cutting board standard.
- Mechanical guards on all controls and power switch for safety and reliability.
- 10ft. power cord bottom-mounted to stay out of they way.
- Stainless steel construction includes legs and undershelf.
- Standard adjustable stationary legs or optional caster set.
- Optional 38099 Caster Set – 4" (10.2 cm) swivel wheels with brakes.
- Shipped knocked down.
- 38003 plugs into standard 15A household or commercial receptacle (no special wiring required).

MODELS:

38102	700W/120V 2 Well	38004	480W/120V 4 Well
38103	700W/120V 3 Well	38005	480W/120V 5 Well
38104	700W/120V 4 Well	38116	600-800W/208-240V 2 Well
38105	700W/120V 5 Well	38117	600-800W/208-240V 3 Well
38002	480W/120V 2 Well	38118	600-800W/208-240V 4 Well
38003	480W/120V 3 Well	38119	600-800W/208-240V 5 Well

PERFORMANCE CRITERIA

ServeWell® Hot Food Tables are designed to hold heated prepared foods at temperatures above the HACCP "danger zone" of 140° F (60° C). The performance standard is measured using the NSF mixture preheated to 165° F (73.9° C). The electric unit will hold the temperature of this product above 150° F (65.6° C). The temperature will be maintained when the food product and inset are used with a standard inset cover, the proper water level is maintained in the well, and the food product is stirred regularly.

ACCESSORIES

Work/Overshelf

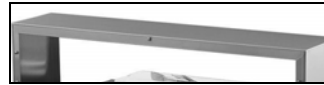

Item	Length/Height
38042	31½" x 13" (80 cm x 33 cm)
38043	46" x 13" (117 cm x 33 cm)
38044	60¾" x 13" (154 cm x 33 cm)
38045	72½" x 13" (192 cm x 13 cm)

Tray Slide

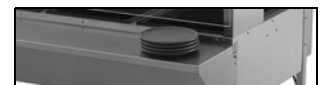

Item	Length/Width
38092	31½" x 10" (80 cm x 25 cm)
38093	46" x 10" (117 cm x 25 cm)
38094	60¾" x 10" (154 cm x 25 cm)
38095	72½" x 10" (192 cm x 25 cm)

Single Deck Cafeteria Guard



Item	Length/Height
38052	31½" x 13" (80 cm x 33 cm)
38053	46" x 13" (117 cm x 33 cm)
38054	60¾" x 13" (154 cm x 33 cm)
38055	72½" x 13" (192 cm x 13 cm)

Caster Set



Item	Description
38099	Caster Kit-two with brakes

Agency Certifications



Approvals

--

Date:



Setting the Standard™

www.vollrathco.com

The Vollrath Company, L.L.C.
 1236 North 18th Street
 Sheboygan, WI 53082-0611
 U.S.A.
 Main Tel: 800.624.2051
 Service Tel: 800.628.0832
 FAX: 800.752.5620

Vollrath of Canada, Ltd.
 6320 Danville Road, Unit 1
 Mississauga, Ontario L5T 2L7
 Canada
 Tel: 905.565.1167
 Tel: 800.695.8560
 FAX: 905.565.1168

SERVEWELL® HOT FOOD TABLE

DIMENSIONS

- Overall Dimensions:
- Dimensions shown in inches (cm).

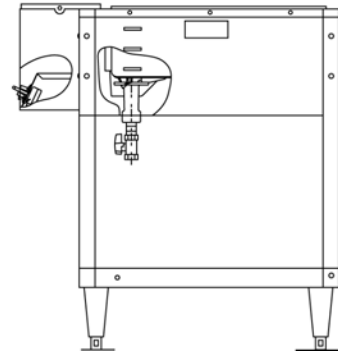
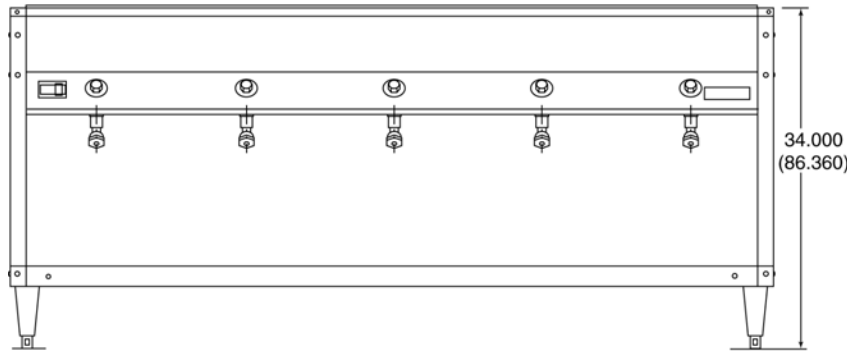
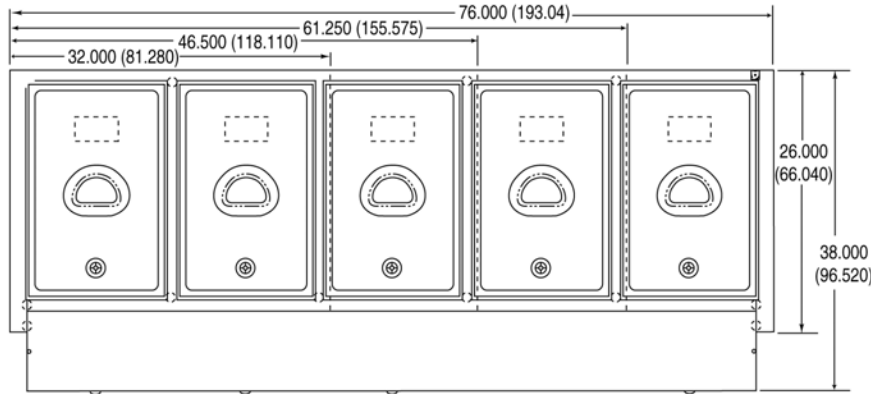

ELECTRICAL SPECIFICATIONS

Item	Description	Dimensions: IN(CM)	Volts	Watts Per Well	Watts Total	Electrical Service (A)	Amps	Plug
700W/120V								
38102	2-well	32 x 32 x 34 (81.3 x 81 x 86)	120V	700	1400	15	11.7	5-15P
38103	3-well	46½ x 32 x 34 (118.1 x 81 x 86)	120V	700	2100	30	17.5	5-30P
38104	4-well	61¼ x 32 x 34 (155.6 x 81 x 86)	120V	700	2800	30	23.3	5-30P
38105	5-well	76 x 32 x 34 (193 x 81 x 86)	120V	700	3500	50	29.2	5-50P
480W/120V								
38002	2-well	32 x 32 x 34 (81.3 x 81 x 86)	120V	480	960	15	8	5-15P
38003	3-well	46½ x 32 x 34 (118.1 x 81 x 86)	120V	480	1440	15	12	5-15P
38004	4-well	61¼ x 32 x 34 (155.6 x 81 x 86)	120V	480	1920	20	16	5-20P
38005	5-well	76 x 32 x 34 (193 x 81 x 86)	120V	480	2400	30	20	5-30P
600-800W/208-240V								
38116	2-well	32 x 32 x 34 (81.3 x 81 x 86)	208-240V	600-800	1200-1600	15	5.8-6.7	6-15P
38117	3-well	46½ x 32 x 34 (118.1 x 81 x 86)	208-240V	600-800	1800-2400	15	8.7-10	6-15P
38118	4-well	61¼ x 32 x 34 (155.6 x 81 x 86)	208-240V	600-800	2400-3200	20	11.5-13.3	6-20P
38119	5-well	76 x 32 x 34 (193 x 81 x 86)	208-240V	600-800	3000-4000	30	14.4-16.6	6-30P

Receptacle Configurations

120V

208-240V



5-15R



5-20R



5-30R



5-50R



6-15R



6-20R



6-30R



www.vollrathco.com

The Vollrath Company, L.L.C.
 1236 North 18th Street
 Sheboygan, WI 53082-0611
 U.S.A.
 Main Tel: 800.624.2051
 Service Tel: 800.628.0832
 FAX: 800.752.5620

Vollrath of Canada, Ltd.
 6320 Danville Road, Unit 1
 Mississauga, Ontario L5T 2L7
 Canada
 Tel: 905.565.1167
 Tel: 800.695.8560
 FAX: 905.565.1168