



Project:

Item Number:

Quantity:

Modular Drop-In: Single Well Hot

The Vollrath Company, L.L.C.

MODULAR DROP-IN: SINGLE WELL HOT



Modular Drop-In: Single Well Hot

DESCRIPTION

The modular drop-in is designed for top-mount installation and does not require hard-wiring. The drop-in comes complete with a six-foot power cord with plug and a four-foot control cord for remote installation.

Full perimeter drip-edge contains spills and condensation within the stainless countertop area of the drop-in. Drip-edge adds additional strength to the flange area.

High-density glass fiber insulation allows use of 625W elements for lower energy consumption and reduced costs while meeting NSF4 performance standards. Also available with 1000W elements. High-density glass fiber insulation and internal design allow the hot well drop-ins to be installed with zero clearance.

Drop-ins can operate wet or dry, however, moist operation is recommended for even heating of the food product.

Stainless wells are 6-3/8" deep to allow use of full-size and fractional pans up to six inches deep while still providing moist heat. Adaptor bars are recommended when using fractional pans.

Agency Listings



MODELS:

	1000W Models	625W Models	Description
120V Infinite Control	36466-01 36466-61	36466 36466-60	Standard Drain Manifold Drain, Auto-Fill
120V Thermostatic Control	36466-11 36466-81	36466-10 36466-80	Standard Drain Manifold Drain, Auto-Fill
208-240V Infinite Control	36467-01 36467-61	36467 36467-60	Standard Drain Manifold Drain, Auto-Fill
208-240V Thermostatic Control	36467-11 36467-81	36467-10 36467-80	Standard Drain Manifold Drain, Auto-Fill

FEATURES

- Top is 18-gauge stainless steel, 18-8 Type 304, with 3/8" overhang on all sides with full perimeter drip-edge, and 19-7/8" x 11-7/8" opening.
- Breaker gasket included for installation under drip-edge.
- Flat work surface around opening.
- Deep drawn stainless steel well is 20-gauge 18-8 stainless, 6-3/8" deep.
- Standard 1000W or 625W heating element.
- Infinite or thermostatic control.
- Power indicator light.
- Standard drain is 1/2" stainless fitting welded to pan with ball valve shutoff below exterior housing.
- Unit insulated on sides, ends and below element assembly with high-density glass fiber insulation.
- Exterior housing is 20-gauge galvanized steel.
- Drop-in is supplied with stainless steel control panel connected to bottom of unit for shipping.
- Control panel may remain on unit or be remote mounted.
- Control wires contained in a 4-ft. flexible rubber cord.
- Unit comes with a 6-ft. cord and plug and does not require hard-wiring installation.
- Positioning clips provided to center drop-in within cutout.
- Standard mounting clips adjustable for up to 3" thick counters.
- Full one-year parts and labor warranty.

Approvals	Date:



Setting the Standard™

www.vollrathco.com

The Vollrath Company, L.L.C.
 1236 North 18th Street
 Sheboygan, WI 53082-0611
 U.S.A.
 Main Tel: 800.624.2051
 Service Tel: 800.628.0832
 FAX: 800.752.5620

Vollrath of Canada, Ltd.
 6320 Danville Road, Unit 1
 Mississauga, Ontario L5T 2L7
 Canada
 Tel: 905.565.1167
 Tel: 800.695.8560
 FAX: 905.565.1168

MODULAR DROP-IN: SINGLE WELL HOT

AUTO-FILL OPTION

Field-installed option that maintains constant water level efficiency. Eliminates the need to monitor wells and add water, reducing operating and labor costs. Attaches easily to manifold drain assembly using simple tools. The check valve/siphon prevents cross contamination of drain and potable water lines.



DIMENSIONS

- ❑ Overall Dimension: 15.00" x 26.00" (38.1 cm x 66.04 cm)
- ❑ Cutout Dimensions: 14.25" x 25.25" (36.195 cm x 64.135 cm)
- ❑ Opening cutout must have a 7/8" (2.222 cm) corner radius.

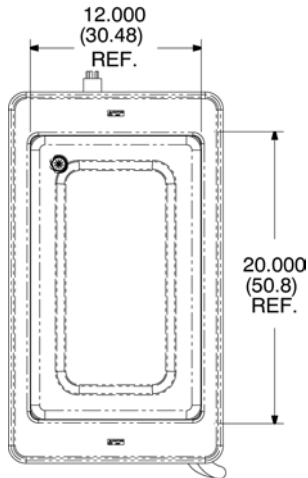

Dimensions shown in inches (centimeters).

Control Panel Cutout +.063/-0 (+.160/-0) Tolerance

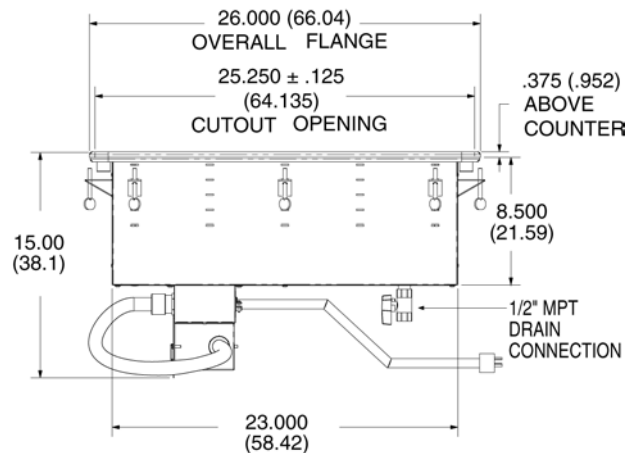
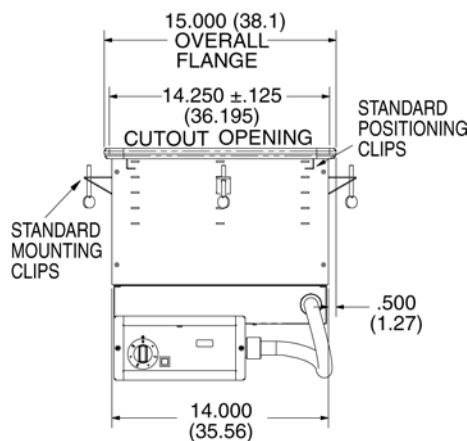
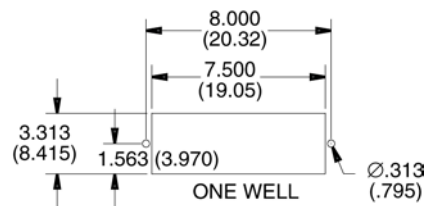

ELECTRICAL SPECIFICATIONS

Model	Total Watts	Volts	Nominal Amps	NEMA Plug
36466, -60, -10, -80	625	120V AC	5.2	5-15P
36466-01, -61, -11, -81	1000	120V AC	8.3	5-15P
36467, -60, -10, -80	470 - 625	208 - 240V AC	2.3 - 2.6	6-15P
36467-01, -61, -11, -81	750 - 1000	208 - 240V AC	3.6 - 4.2	6-15P

Receptacles

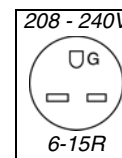
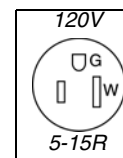

www.vollrathco.com

The Vollrath Company, L.L.C.
1236 North 18th Street
Sheboygan, WI 53082-0611
U.S.A.
Main Tel: 800.624.2051
Service Tel: 800.628.0832
FAX: 800.752.5620

Vollrath of Canada, Ltd.
6320 Danville Road, Unit 1
Mississauga, Ontario L5T 2L7
Canada
Tel: 905.565.1167
Tel: 800.695.8560
FAX: 905.565.1168