



HyPerSteam Pressureless Steamer models HY-5E/EF

Description

Steamer shall be a Groen Model HY-5E stainless steel pressureless steamer with a self-contained atmospheric 15.5 KW electric steam generator, per Bulletin 140807, as follows:

Construction

Steamer cavity and cabinet shall be all stainless steel construction, with removable right and left-side panels, providing access to internal components.

Steamer door is all stainless steel with a strong continuous hinge and is field-reversible for left or right-swing, door shall be provided with a one-piece, replaceable seal. Easy-open handle and latch shall provide positive lock and seal when door is pushed or slammed shut.

Hidden magnetic door switch cuts power to blower and cuts power to generator when the door is opened. Pan support racks shall be polished stainless steel and removable for easy cleaning. A stainless steel condensate collection tray is positioned under cavity door.

Finish

Cabinet exterior, including door, shall be finished to a No. 4 uniform finish. Cavity interiors are polished stainless steel. Control panel face plates shall be smudge-resistant polyester film, ensuring maximum ease in cleaning and maintaining an attractive appearance.

UL Listing

Steamer shall be UL-listed and Canadian UL-listed.

Sanitation

Unit shall be designed and manufactured to meet NSF requirements and be NSF-listed. Unit shall allow operator to delime steam generator through access port on top without tools or service call. Push button auto-delime feature is standard.

Controls

Steamer controls shall include an ON-OFF power button; 60-minute electro-mechanical timer, with continuous steam setting; and READY light which indicates when cavity is ready for steaming. Auto-Delime button initiates deliming cycle.

Performance Features

Steamer cavity shall have a powerful side-mounted blower, which increases steam velocity and provides efficient steam distribution throughout cavity and between loaded pans. Steam generator delivers 3.1 KW power input per 2 1/2" deep steam pan.

Heat-up time to READY shall be 8-10 minutes or less, under normal conditions. Cavity is kept warm and ready for instant steam between loads. No cavity warm up required, after READY light comes on.

DELIME indicator light warns operator of need to delime steam generator. Unit will shut off if water level is low. When power is turned "off", unit automatically blows down the steam generator to reduce sediment build-up.

Model HY-5E Shown



Atmospheric Steam Generator

Unit shall have an electric-heated, rear-mounted steam generator to provide atmospheric steam to the chamber at a temperature of approximately 212°F. Steam generator has an electric water sensor. Electric heating elements are replaceable from the side.

Pan Capacity

Pan Size / Type	Number
12 x 20 x 1"	10
12 x 20 x 2 1/2"	5
12 x 20 x 4"	3

Installation

Unit requires 208, 240 or 480 Volt, single or three-phase electric service. Unit requires dual 3/4" NH cold water supply lines and 2" free venting drain.

Water Supply Requirements

All steam systems are subject to contamination and failure due to mineral content found in all water supplies. To minimize service problems, a Groen PureSteam™ Water Treatment System is recommended.

Options/Accessories

- Groen PureSteam™ Water Treatment System
- Factory stacking kit (See Bulletin 75A)
- Stainless steel support stand
- Pan racks for support stand
- Single water connection (cold water)

Origin of Manufacture

Steamer shall be designed and manufactured in the United States.

5-Pan Capacity
Stainless Steel
Pressureless Steamer

Table Top
Self-Contained
Electric-Heated

Short Form

Unit shall be a Groen HyPerSteam pressureless steamer Model HY-5E with self-contained, atmospheric electric-heated steam generator, per Bulletin 140807. All stainless steel construction, with powerful blower to circulate steam within cavity. Standard operating controls including: 60-minute electro-mechanical timer, constant steam setting, ready light and Delime cycle button to initiate deliming. Simple generator deliming through port on top. Door is field-reversible, with easy-open latch and hidden magnetic door switch. The atmospheric steam generator requires no pressure gauge or switches, has automatic drain and 15.5 KW power input. Unit shall come up to steam in 8-10 minutes from a cold start, and provide warm cavity-instant steam capability. See other side for required electric, water and drain connections. Made in the U.S.A.



Applications

- Pasta
- Rice
- Vegetables (Fresh & Frozen)
- Seafood (Fresh & Frozen)
- Poultry
- Potatoes
- Eggs
- Meats
- Reheat Cook-Chill & Prepared Foods

SERVICE CONNECTIONS & NOTES:

- ① DRAIN CONNECTION: 2" [50.8] TUBE (DRAIN FREE VENTING).
- ② COLD WATER SUPPLY AT 30 TO 60 PSIG WITH A FLOW RATE OF 0.75 - 1.50 GPM AND WITH A 3/4" NH CONNECTION.
- ③ ONE ELECTRICAL CONNECTION: 1" [25.4] CONDUIT FITTING.
- ④ MINIMUM REAR AND SIDE CLEARANCE: REAR = 6" [152.4] LEFT SIDE = 2" [50.8] RIGHT SIDE = 2" [50.8]
- ⑤ DIMENSIONS IN BRACKETS [] ARE MM.

ELECTRICAL REQUIREMENTS			
VOLTAGE	PHASE	AMPS	MAX. KW
208	1	74.5	15.5
	3	44.0	15.5
240	1	64.6	15.5
	3	38.2	15.5
480	3	19.1	15.5

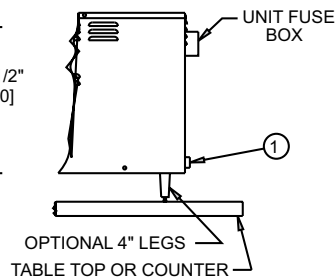
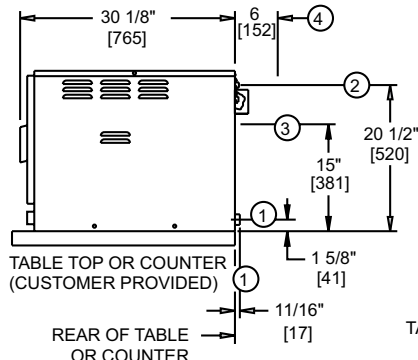
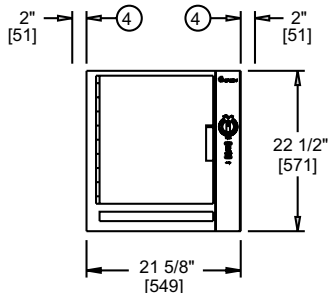
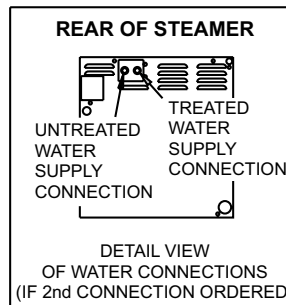
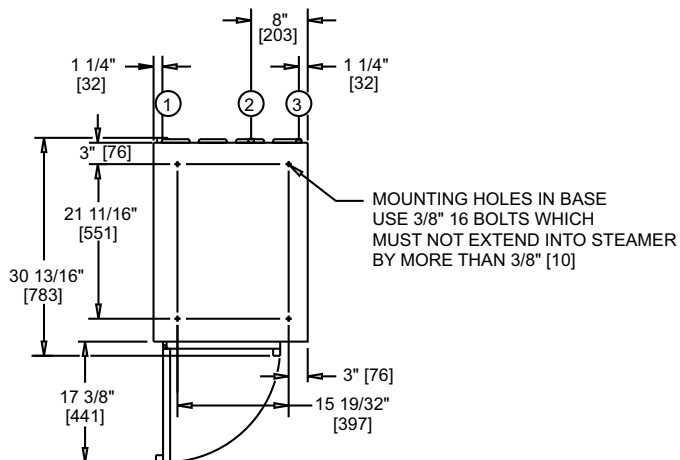

OPTIONAL SUPPORT STAND

