



Direct Steam Kettle model D

Description

Kettle shall be a Groen Model D (Specify 20, 40 or 60-gallon) stainless steel, 2/3 steam jacketed unit operating from a direct steam.

Construction

Kettle interior shall be of 18.8 - 316 type stainless steel with, solid one-piece welded construction. Kettle jacket shall be 304 stainless steel, solid one piece construction. Unit shall be furnished with a heavy reinforced bar rim with a heavy-duty, butterfly-shaped pouring lip for maximum sanitation, pouring control, and durability.

Kettle body shall be supported by a stainless steel yoke stand with pedestal base. Self-locking work gear tilt mechanism and rotary steam joint are completely enclosed in stainless steel housing, mounted on the right kettle support arm. Large hand crank provides easy operator tilting and precise pouring control. Faucet mounting bracket is standard.

Finish

Kettle interior shall be polished to a 180 emery grit finish. Exterior of kettle shall be finished to a semi-deluxe buff finish, ensuring maximum ease in cleaning and maintaining brilliant appearance.

ASME Code

Unit shall be ASME shop-inspected, stamped and registered with the National Board for operation up to a maximum working pressure of 25 PSI.

Sanitation

Unit shall be designed and constructed to be NSF-listed, meeting NSF and all known health department and sanitation codes.

Steam Pressure

Kettle shall operate dependably at any steam pressure between 5 and 25 PSI. Higher working pressures available.

Mounting

Outer circumference of pedestal base is flanged down vertically to ensure proper sealing and easy mounting to floor or deck.

Installation

Remote steam source required. Steam trap assembly is required and not provided unless ordered as an option. (See below) See dimension T on other side for steam inlet size and number.

Model D shown



Options/Accessories

- Basket Inserts
- Water fill faucets (single or double pantry)
- No. 31 lift-off cover or No. 51 counter balanced hinged cover
- 2" or 3" tangent draw-off valve (20 & 40-gal. only)
- Cold water cooling
- Steam trap assemblies
- Kettle brush kit

Origin of Manufacture

Kettle, shall be designed and manufactured in the United States.

**Stainless Steel
2/3 Steam Jacketed Kettle**

**Pedestal Mounted
Tilting
Direct Steam
40 to 60-Gallon
Capacities**

Short Form

GROEN Model D (Specify gallons) stainless steel, 2/3 jacketed tilting, direct steam kettle. Solid one-piece welded construction of type 316 stainless steel liner and 304 stainless steel jacket with heavy reinforced bar rim and pouring lip welded to top rim of kettle, mounted on pedestal and yoke stand. Quick-action self-locking worm gear tilt mechanism standard. NSF-listed. ASME code-constructed and National Board registered for operation up to 25 PSI. Made in USA.



Applications

Stews
Soups
Poultry
Sauces
Gravies
Pie Fillings
Pasta
Rice

	TABLE OF DIMENSIONS					
	CAPACITY (GALLONS/LITRES)			CAPACITY (GALLONS/LITRES)		
	20 GAL/76 LTRS. INCHES	40 GAL/152 LTRS. MM	60 GAL/228 LTRS. INCHES	40 GAL/152 LTRS. MM	60 GAL/228 LTRS. INCHES	MM
A	20	508	26	660	30	762
B	16-1/8	410	19-1/4	489	21-1/4	540
C	20-1/8	511	23-3/4	603	25-3/4	654
D	36-1/4	921	43	1092	47	1194
E	23	584	30	762	34	864
F	13	330	17	432	19	483
G	18-1/2	470	22	559	25	635
H	36	914	38-1/2	978	43	1054
J	24-1/2	622	26	660	28-1/2	679
K	10-5/8	270	9	229	7-3/4	197
L	36	914	38	965	42	1067
M	11-1/2	292	12-1/2	318	14-1/2	368
N	12	305	15	381	16	406
P	14-3/4	375	13-3/4	349	N/A	N/A
Q	11-1/2	292	12-1/2	318	N/A	N/A
R	16	406	16	406	18	457
S	14-1/2	368	14-1/2	368	16-1/2	419
T	3/4	13	3/4	19	3/4	19

NOTES:

1. 2" TANGENT DRAWOFF AND VALVE FURNISHED WHEN SPECIFIED AT EXTRA COST.
2. FOR KETTLES WITH 2" TANGENT DRAWOFF, ADD 5" (20 GAL.) & 7" (40 GAL.) TO DIMENSIONS H, J AND K.
3. APPROX. 5 PSI REQ'D TO PUSH CONDENSATE UP DRAIN TUBE.
4. PEDESTAL MUST BE SECURELY ANCHORED AND SEALED TO THE FLOOR.
5. IF TANGENT DRAWOFF IS REQD. ON 60 GAL. KETTLE, ORDER MODEL DLT (TRIP-LEG KETTLE).

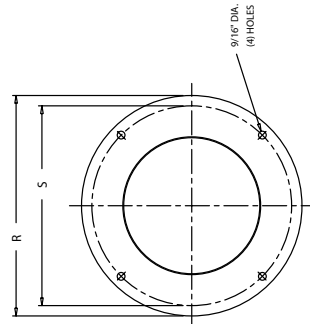

SECTION A-A
FLOOR MOUNTING LAYOUT

