

BPP-30G/40G



Model BPP-30G Shown

Description

Braising pan shall be a Groen Eclipse™ Ergonomic Tilting Braising Pan Model BPP-30G or BPP-40G, gas-heated, power tilting (specify 30 gallon) model BPP-30G or (specify 40 gallon) model BPP-40G with 10" deep pan on a rounded leg stand.

Construction

The pan body shall be of type 304 stainless steel, solid one-piece welded heavy-duty construction, with 10" pan depth. All exposed surfaces shall be of stainless steel.

The cooking surface is a heavy 5/8" thick stainless steel clad plate with specially designed welded heat transfer fins, heated by the gas burner/combustion chamber. This combination delivers more uniform heat transfer over the entire cooking surface. The heavy plate prevents warping or distortion. (SEE OPERATOR'S MANUAL FOR PROPER WARM UP SETTINGS).

Controls and tilt mechanism are mounted in stainless steel housings, on the pan body sides. Braising pan shall come standard with a mounting bracket for either right-side, left-side or rear faucet mounting.

Finish

Interior of braising pan shall be polished to a 100 emery grit finish. Exterior of braising pan shall be finished to a bright high buff semi-deluxe finish, ensuring maximum ease in cleaning and maintaining brilliant appearance.

C.S.A. Design Certification

Braising Pan shall be design-certified by CSA International (formerly AGA) for use with Natural Gas or LP Gas.

Sanitation and NSF Listing

Braising pan shall be designed and constructed to be NSF- listed, meeting all known health department and sanitation codes. True rounded leg tubular stand design and 3" radius pan interiors make cleaning easier.

Power Tilt

The braising pan shall have a smooth-action quick-tilting body with motorized crank tilt mechanism, which provides

precise control during pouring of pan contents for easy operation. A powerful reversing DC motor is activated by a 3-position control switch. Unit shall have an easy access, manual override capability to tilt the pan in case of power failure. Pan body shall tilt past vertical to assist in cleaning.

Vented Cover

A heavy-gauge fully adjustable one-piece cover is standard with torsion bar type counterbalance designed to maintain the selected cover position. A vent is provided in the cover top to regulate condensate buildup and a rear condensate drip shield is located under the cover to prevent condensate from dripping on floor when cover is opened.

Controls

Operating controls include console-mounted ON power switch, ON power indicator light, HEAT indicator light, temperature control and motor tilt switch.

Performance Features

Braising pan shall be equipped with controls that allow operation at 7 degree angle to facilitate griddling. Braising pan shall be thermostatically-controlled for automatic shut-off when desired temperature is reached and automatic power ON when temperature falls below desired setting. Model BPP-30G has a firing rate of 104,000 BTU/hr. Model BPP-40G has a firing rate of 144,000 BTU/hr. Electronic intermittent pilot ignition system is standard.

Installation

Unit requires 1/2" NPT gas connection. Requires one 115 Volt, single-phase, 60 HZ, 5 AMP supply.

Options/Accessories

- Single pantry water fill faucet
- Double pantry water fill faucet
- Steamer pan carrier (Model BPC)
- 2" tangent drawoff valve (option: must be ordered with unit)
- Etch Marks (option: must be ordered with unit)
- Gas Quick Disconnect
- Flanged feet
- Strainer for tangent draw-off valve
- Pouring lip strainer
- Steamer pan inserts
- Single or Double pantry faucet with spray hose assembly (48" or 60")
- Casters

Origin of Manufacture

Braising pan shall be designed and manufactured in the United States.

Narrow Width
Stainless Steel
Power Tilting
Braising Pan

Rounded Leg
Gas-Heated
30- and 40-Gallon
Capacity

Short Form

Braising Pan shall be Groen Eclipse™ Ergonomic Tilting Braising Pan stainless steel gas-heated thermostatically controlled Model BPP- 30G or BPP-40G, on a rounded tubular leg stand. Heavy 5/8" thick stainless steel clad pan bottom with specially designed gas burner/combustion chamber and specially-designed welded heat transfer fins. Electronic ignition is standard; 30 gallon pan is 39" wide and 40 gallon pan is 48" wide both with a 10" deep pan. Smooth-action, motorized tilt mechanism, heavy-duty fully adjustable counter balanced cover with condensate drip shield and cover vent. NSF listed and CSA design-certified. 1/2" NPT gas connection required and standard electric spark ignition requires 115 Volt, single-phase, 60 Hertz, 5 AMP supply. Specify Natural Gas or LP Gas. Made in U S A.



Applications

Braising meat
Pan frying chicken
Asian stir-fry
Steaming vegetables
Frying short order items
Sauteing
Sauces/Roux
Roasting turkeys
Boiling
Simmering
Thawing
Reheating prepared foods



Stainless Steel
Power Tilting
Braising Pan

BPP-30G/40G

| GAS FEED RATE: INCHES WATER COLUMN -RECOMMENDED INCOMING- | |
|---|---------------------------------|
| NATURAL GAS | 4.5" W.C. MIN. 14" W.C. MAX. |
| PROPANE GAS | 11" W.C. MIN. 14" W.C. MAX. |

| TABLE OF DIMENSIONS | | | | | |
|---------------------|---------|---------|-------|------|--|
| MODEL | BPP-30G | BPP-40G | | | |
| DIMS. | INCH | MM | INCH | MM | |
| A | 26.25 | 667 | 35.75 | 908 | |
| B | 32.00 | 813 | 41.5 | 1054 | |
| C | 38.50 | 984 | 48.00 | 1226 | |
| D | 8.75 | 222 | 13.50 | 343 | |

| PERFORMANCE DATA | | |
|-----------------------|---------|---------|
| MODEL | BPP-30G | BPP-40G |
| FIRING RATE BTU/HR | 104,000 | 144,000 |
| CAPACITY | GALLONS | 30 |
| | LITERS | 114 |
| | | 152 |

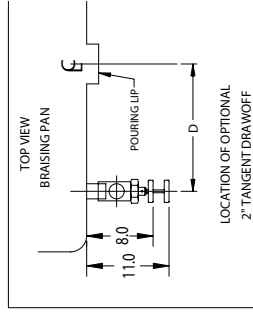

146527 REV C

- NOTES:
1. DIMENSIONS IN BRACKETS [] ARE MM.
 2. CASTERS OR FLANGED FEET AVAILABLE AT AN EXTRA COST.
 3. ELECTRICAL CONNECTION: 0.875" DIA. (22) HOLE
115 V, 1 PH, 60 HZ, 5 AMPS.
 4. GAS CONNECTION: 1/2" NPT.
 5. FAUCET BRACKET MAY BE INSTALLED ON LEFT OR RIGHT SIDE.
 6. FAUCET MAY BE INSTALLED ON FAUCET BRACKET OR ON REAR AS SHOWN.

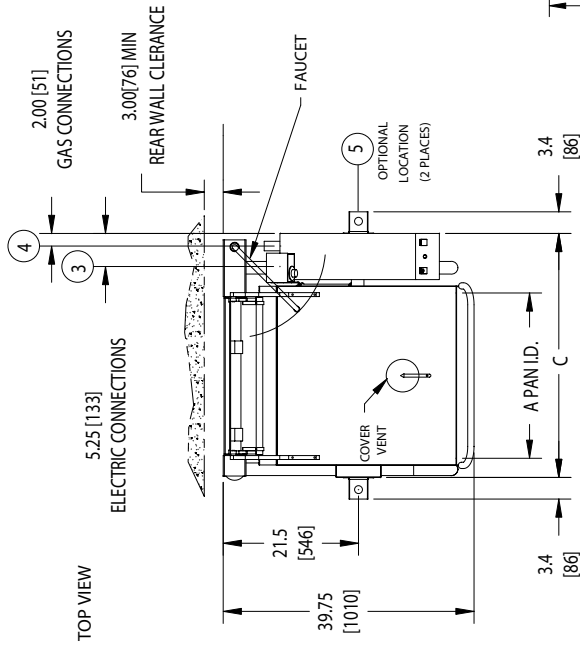

RIGHT SIDE VIEW

