

Spec Sheet No. SL-19

Job Name _____

Item No. _____

Blender Station with Dump Sink

◦ SL-RS-15

Note: Units are supplied with two individual legs and one leg channel for universal mounting. (right or left)

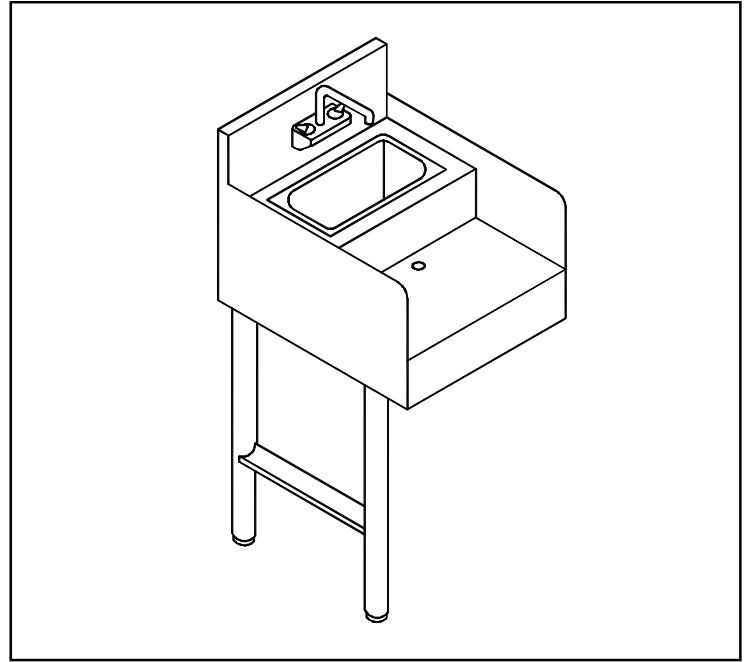

Specifications

•**Sink Bowl:** 6"L x 11"W x 6"D 20 gauge 300 series stainless steel seamless deep drawn.

•**Recess Step:** 22 gauge 300 series stainless steel.

•**Electrical:** 15A - 120V duplex receptacle.

•**Backsplash:** 22 gauge 300 series stainless steel.

•**Sides:** 16 gauge 430 series stainless steel.

•**Legs:** 1-5/8" O.D. 18 gauge galvanized with electro static black powder coat and black plastic adjustable bullet feet. To include stainless steel legs add the suffix -SS.(Optional)

•**Plumbing:** 1" I.P.S. drain.

•**Faucet:** 4" on center splash mount with gooseneck swivel spout.



Supreme Metal



