

# Challenger

Spec Sheet No. CR-7

Job Name \_\_\_\_\_

Item No. \_\_\_\_\_

## Ice Bin / Cocktail Unit

- CRJ-15
- CRJ-24
- CRJ-36

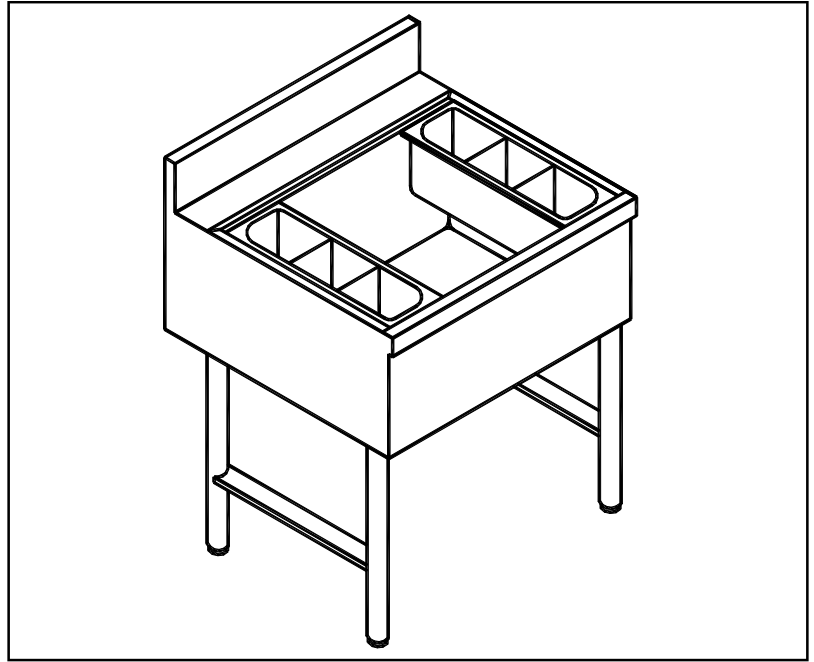

## Specifications

•**Ice Bin:** 22 gauge 300 series stainless steel.

•**Front Apron:** 22 gauge 300 series stainless steel.

•**Sides:** 20 gauge 430 series stainless steel.

•**Backsplash:** 22 gauge 300 series stainless steel.

•**Insulation:** 2 lb. density styrofoam.

•**Under Structure:** 22 gauge galvaneal fronts and backs, 11 gauge electrogalvaneal leg channel.

•**Legs:** 1-5/8" O.D. 18 gauge galvanized with electro static black powder coat and black plastic adjustable bullet feet. To include stainless steel legs add the suffix -SS.(Optional)

•**Plumbing:** 1" I.P.S. drain.

•**Bottle Rack:** (2) Injection molded plastic.



Supreme Metal



# Challenger

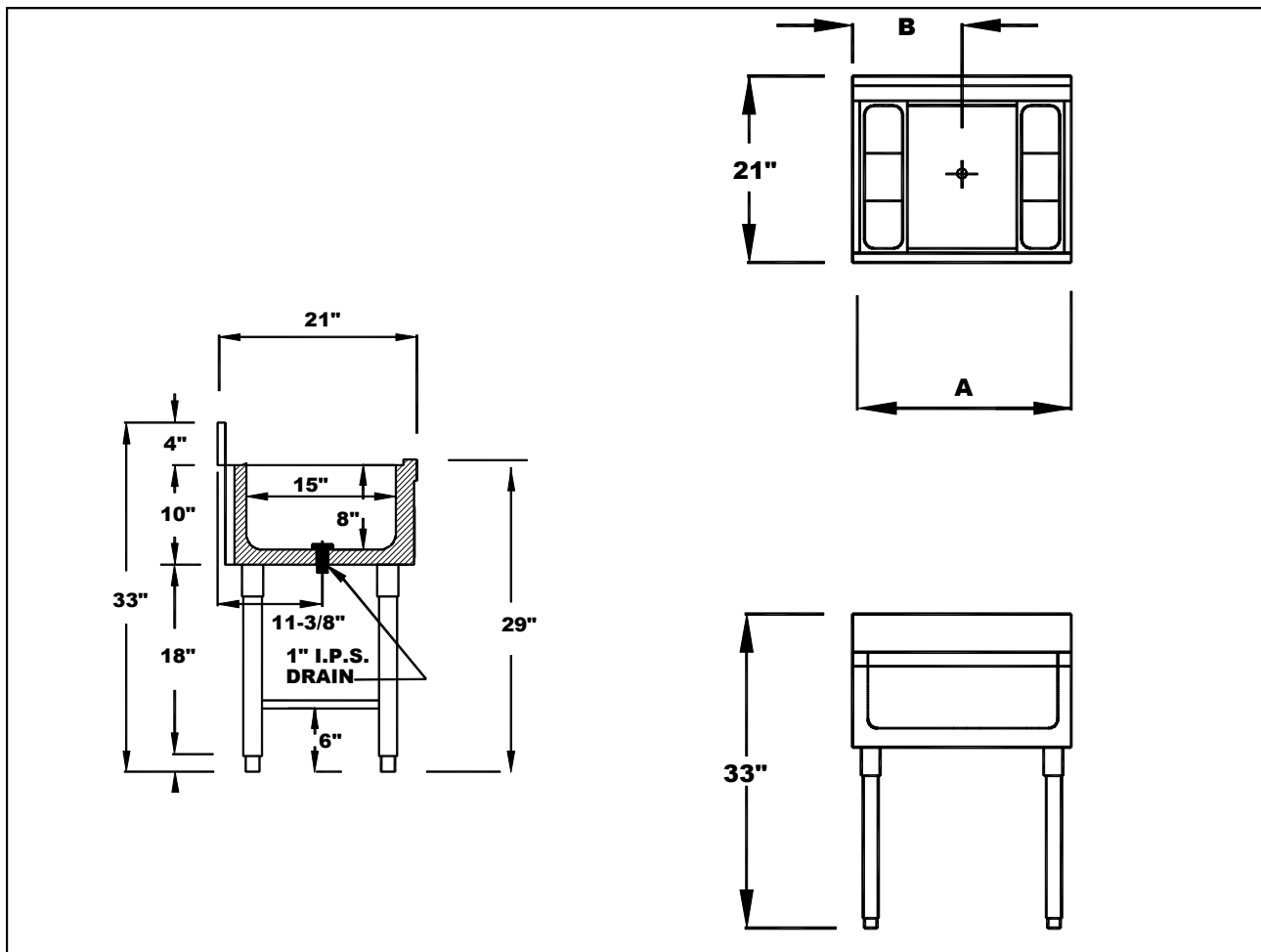

| Model Number | Dimension A | Dimension B | Ice Capacity | Packaged Weight | Packaged Cubic Feet |
|--------------|-------------|-------------|--------------|-----------------|---------------------|
| CRJ-15       | 15"         | 7.5"        | 35 lbs.      | 48 lbs.         | 6                   |
| CRJ-24       | 23"         | 11.5"       | 74 lbs.      | 53 lbs.         | 7.2                 |
| CRJ-36       | 35"         | 17.5"       | 110 lbs.     | 66 lbs.         | 10.1                |

SupremeMetal is constantly engaged in a program of improving their products. We reserve the right to change our specifications without prior notice.