

Ice-O-Matic®

ICEU150 - Self Contained Cube Ice Maker



ICEU150

Features

- Space saving 24" (610 mm) wide undercounter design.
- Produces up to 174 lbs (79 kg) of ice per day.
- *Harvest Assist* provides consistent ice production for the life of the ice maker while reducing energy consumption and increasing capacity.
- *Pure Ice*® exclusively by Ice-O-Matic. Built-in antimicrobial protection for the life of the ice maker inhibits bacteria growth on ice maker surfaces. Ice-O-Matic's optional water filtration system provides protection against unpleasant tastes, odors and scale formation.
- Durable, electroless nickel plating on all evaporator plates ensures reliability.
- *Longest warranty in the industry.* Purchase an Ice-O-Matic water filter with your cube ice maker, replace the filter every six months, and the evaporator warranty is extended to 7 years parts and labor (*available in the U.S. and Canada only*).
- Constructed from corrosion-resistant stainless steel and fingerprint-proof plastic.

Options & Accessories

Water Filters			
Ice Machine Model	Manifold		Inline
	System	Replacement	System
ICEU150	IFQ1	IOMQ (1)	IF4C / IF18C

Ice Maker Warranty

Every Ice-O-Matic ice maker is backed by a warranty that provides both parts and labor coverage.

- Three years **Parts and Labor**.
- Five years **Parts** coverage on the evaporator and compressor.
- Seven years **Parts and Labor** on the evaporator when you purchase an Ice-O-Matic water filter with your cube ice maker and replace the filter every six months (*available in the U.S. and Canada only*).

Ice Form



Full Cube	
W x D x H (in)	7/8 x 7/8 x 7/8
W x D x H (mm)	22 x 22 x 22
Half Cube	
W x D x H (in)	7/8 x 7/8 x 3/8
W x D x H (mm)	22 x 22 x 10

Space-Saving Solutions

- Front air discharge design for compact spaces.
- Low profile top saves counter space.
- Stores up to 73 lbs (34 kg) of ice.
- Easy front access to ice.
- Available with an air-cooled or water-cooled condenser.

ICEU150 Self Contained Cube Ice Maker



Ice-O-Matic®

ICEU150 Self Contained Cube Ice Maker

Air and Water Cooled

- A. Ice maker water in, 3/8" FPT.
- B. Bin and ice maker drain, 3/4" FPT.
- C. Hole for electrical connections, 7/8".
- D. Condenser water in, 3/8" FPT (*water cooled units only*).
- E. Condenser water out, 1/2" FPT (*water cooled units only*).

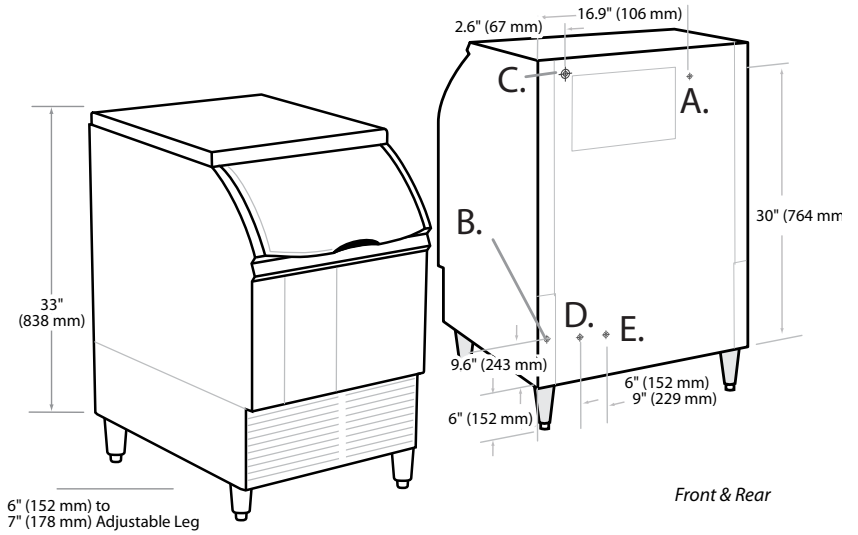
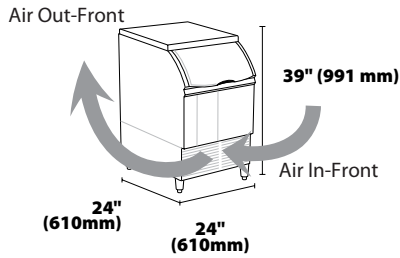

Operating Requirements

	Minimum	Maximum
Ambient Temp. Range Air	50°F (10°C)	100°F (38°C)
Water Temperature	40°F (4.4°C)	100°F (38°C)
Water Pressure	20 PSIG (1.4 BAR)	60 PSIG (4.1 BAR)

Dimensions

All Models	
W x D x H (inches)	24 x 24 x 39
W x H x D (mm)	610 x 610 x 991

Specifications

Model Number	Cond. Unit	Ice Production per 24hrs		Water Usage gallons per 100 lbs of Ice 90°F air/70°F water		kWH Used per 100 lbs of ice @ 90°F air/70°F water	Voltage Characteristics	TTL Load Amps	Fuse Size	Approx. BTUs per hour
		70°F air/50°F water lbs (kg)	90°F air/70°F water lbs (kg)	Potable	Condenser					
ICEU150A ★	Air	174 (79)	112 (51)	34.0	-	11.8	115/60/1	9.7	15	3,572
ICEU150W	Water	174 (79)	144 (65)	32.2	152	8.0	115/60/1	7.9	15	3,569

NOTES:

Number of Wires: 3 (including ground)
 Approx. Shipping Weight lbs (kg): ICEU150A 160 (73) • ICEU150W 160 (73)
 Refrigerant Type: R404A

★ ENERGY STAR qualified machine.

Please see our website www.iceomatic.com for the latest list of ENERGY STAR qualified machines and available rebates