



# W5A Food Mixer

Project \_\_\_\_\_  
 Item \_\_\_\_\_  
 Quantity \_\_\_\_\_  
 CSI Section 11400 \_\_\_\_\_  
 Approval \_\_\_\_\_  
 Date \_\_\_\_\_

W5A Food Mixer

## Models

W5A



## Standard Features

- Powerful 4/10 hp motor with cord and NEMA 5-15P plug
- Overload protection and no voltage release
- Attachment hub
- UL and NSF Listed
- Neoprene feet to minimize walking, rusting or counter damage
- Permanently lubricated planetary head and attachment hub case
- Stainless steel 5-qt. bowl, wire whip, dough hook and flat beater.

## Options & Accessories

- Vegetable slicer and shredder plates
- Meat grinder
- Bowl Lid

## Specifications

### General Description

The Varimixer Model W5A is an extremely rugged 5-quart mixer, combining an industry leading 4/10 hp (300 watts) direct drive with our proven 5 speed transmission. This combination provides plenty of torque at the beater shaft for maximum batch sizes. The W5A features very efficient agitators to quickly produce quality food products. The mixer is operated by the 2 rotary knobs, one on each side. Either knob can be used to adjust the speed or raise the mixing head.

The W5A features a wide agitator speed range from 70 rpm to 400 rpm. The W5A has the versatility and the performance to handle all your mixing needs from bread dough to the lightest whipped cream.

### Construction

The W5A frame is of aluminum construction for strength and rigidity. All ball bearings and needle bearings are sealed to protect from foodstuff and moisture

damage. Durable powder coated finish is used on those surfaces not constructed of stainless steel.

Extensive use of stainless steel means quick clean-up and long life. The planetary cover, beater shaft, agitator shaft, bowl, beater, whip, and dough hook and bowl screen are all constructed of stainless steel.

### Standard Accessories

The W5A comes equipped with all stainless steel accessories including bowl screen, 5 qt. bowl, wire whip, dough hook, flat beater, ingredient chute and a plastic bowl cover.

### Attachment Hub

The W5A is equipped with an attachment hub specific for the Vegetable Slicer and Meat Mincer as shown to the right.



5489 Campus Drive  
 Shreveport, LA 71129 USA

Tel: 318-219-7051  
 Tel: 1-800-222-1138  
 Fax: 318-635-3131  
 E-mail: [mix@varimixer.com](mailto:mix@varimixer.com)

[www.varimixer.com](http://www.varimixer.com)  
 Bulletin No. W5A 09/07



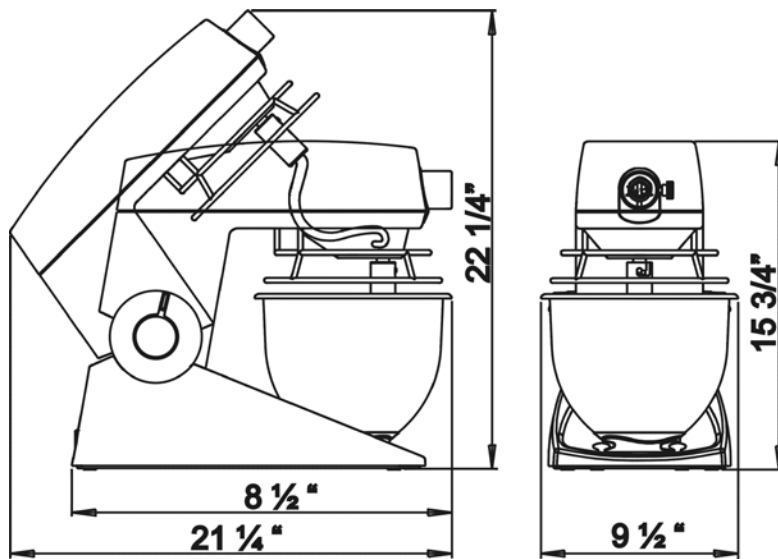

**DIMENSIONS**

MODEL NO.	CAPACITY	OVERALL SIZE (cm)			NET WEIGHT	SHIPPING INFORMATION					
		HEIGHT	WIDTH	LENGTH		WEIGHT	CLASS	CU. FT.	DIMENSIONS		
W5A	Large Bowl. 5-Qt.	15 3/4" (40.05 cm)	9 1/2" (24.13 cm)	21 1/4" (53.975 cm)	44 lbs. (19.958 kg)	52 lbs. (23.58 kg)	85	25	<b>H</b> 18" (45.72 cm)	<b>W</b> 24" (60.96 cm)	<b>L</b> 18" (45.72 cm)

**ELECTRICAL DATA FOR MOTOR**

\*115VAC Supply/60 HZ/1 Phase  
 Feed Wires incl. Ground..... 3  
 Motor Power .....HP ..... 4/10  
 Amperes, full load .....A .....3  
 Power cord included with plug NEMA 5-15P

**MIXING SPEED**

Agitator Speed .....Min..... 70  
 Agitator Speed .....Max.....400

$$\%AR = \frac{\text{weight of water}}{\text{weight of flour}}$$

Batch size and/or speed reduction is required if any of the following conditions exist.

1. High Gluten Flour
2. AR % under 40%
3. Water Temperature under 65 Degrees F

\*On the nominal motor voltage, + or - 10% tolerance is allowed.



Standard tools: Stainless Steel Wire Whip, hook and beater.  
 Bowl shown with optional plastic Bowl Lid

5489 Campus Drive  
 Shreveport, LA 71129 USA

Tel: 318-219-7051  
 Tel: 1-800-222-1138  
 Fax: 318-635-3131

E-mail: [mix@varimixer.com](mailto:mix@varimixer.com)

[www.varimixer.com](http://www.varimixer.com)

Bulletin No. W5A 09/07

Litho in U.S.A. ©Varimixer.

