



W20A Food Mixer

Project _____
 Item _____
 Quantity _____
 CSI Section 11400 _____
 Approval _____
 Date _____

W20A Food Mixer

Models

W20A



Standard Features

- Powerful 1 hp motor with cord and NEMA 5-15P plug
- Overload protection and no voltage release
- #12 attachment hub with 90 to 400 rpm speed range
- Bowl Screen
- Neoprene feet to minimize walking, rusting or counter damage
- Provisions for bolting to counter or table
- Permanently lubricated planetary head and attachment hub case
- 15-minute timer
- Stainless steel 20-qt. bowl, wire whip, flat beater and dough hook

Options & Accessories

- 12-qt. bowl and accessories
 - Bowl scraper in 20-qt. and 12-qt. sizes
 - Stainless steel wing whip
 - Pastry knife
 - Vegetable slicer and shredder plates
 - Meat grinder
 - Bowl Screen Ingredient Chute
 - Stainless steel Column
 - 25-qt. stainless steel bowl
 - Stainless table with legs
 - Stainless table with castors
 - Stainless steel base.
- (Tables and Base shown below)

Specifications

The Varimixer Model W20A is our most rugged 20-quart mixer, combining an industry-leading 1 hp drive with our proven variable speed transmission. This combination provides plenty of torque at the beater shaft for maximum batch sizes. The W20A features very efficient stainless steel agitators to quickly produce quality food products.

The W20A can be equipped with a stainless steel automatic bowl scraper. The bowl scraper eliminates intermediate stopping during recipe preparation, saving time and improving sanitation.

The W20A features a wide agitator speed range from 100 rpm to 400 rpm. The W20A has the versatility and the performance to handle all your mixing needs from the heaviest pizza dough to the lightest whipped cream.

The W20A frame is of welded plate steel construction for strength and rigidity. All ball bearings and needle bearings are sealed to protect from foodstuff and moisture damage. Durable powder coating finish is used on those surfaces not constructed of stainless steel. A stainless steel body is optional.

Stainless steel is extensively used in the construction of the W20A for quick cleanup and long life. The top cover, planetary cover, beater, dough hook, whip agitator shaft, bowl, hook, whip wires, control handles and bowl clamps are constructed of stainless steel.

The W20A is equipped with a #12 attachment hub. The speed range for the hub is 90 to 400 rpm.



223



223C



223B



5489 Campus Drive
 Shreveport, LA 71129 USA

Tel: 318-219-7046
 Tel: 1-800-222-1138
 Fax: 318-635-3131
 E-mail: mix@varimixer.com

www.varimixer.com
 Bulletin No. W20A 03/10



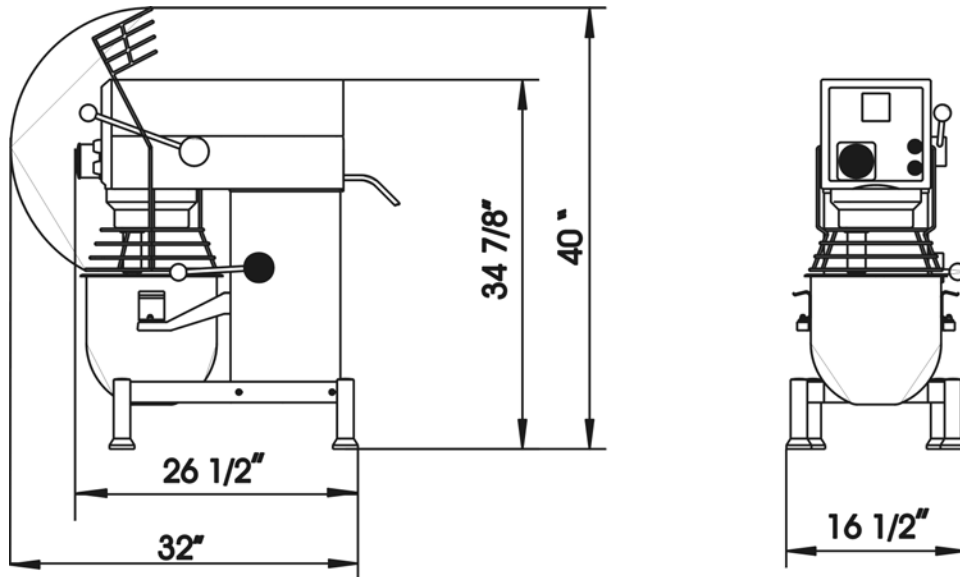

DIMENSIONS

MODEL NO.	CAPACITY	OVERALL SIZE (cm)			NET WEIGHT	SHIPPING INFORMATION						
		HEIGHT	WIDTH	LENGTH		WEIGHT	CLASS	CU. FT.	DIMENSIONS			
W20A	Large Bowl. 20-Qt. Small Bowl 12-Qt.	34.875" (88.6 cm)	16.5" (41.91 cm)	26.5" (67.3 cm)	216 lbs. (98 kg)	293 lbs. (133 kg)	85	25	H 47" (119.4 cm)	W 29" (73.7 cm)	L 32" (81.3 cm)	

ELECTRICAL DATA FOR MOTOR**

*115VAC Supply/60 HZ/1 Phase
 Feed Wires incl. Ground..... 3
 Motor PowerHP 1
 Amperes, full loadA 12
 Power cord included with plug NEMA 5-15P

MIXING SPEED

Agitator SpeedMin.....100
 Agitator SpeedMax.....400

%AR= weight of water
weight of flour

Batch size and/or speed reduction is required if any of the following conditions exist.

1. High Gluten Flour
2. AR % under 40%
3. Water Temperature under 65 Degrees F

*On the nominal motor voltage, + or - 10% tolerance is allowed.

**Also available in 220/60/1, 220/50/1, 110/50/1 and 440/60/3. Not submitted for UL listing.

***Varimixer also features our Model W20P specifically designed for pizza and pretzel dough.

CAPACITY CHART

Mashed Potatoes	Whip or Beater	17 lbs.
Whipped Cream	Whip	4 Qts.
Muffins	Beater	24 lbs.
Layer Cake	Beater	23 lbs.
Pie Dough	Pastry Knife	21 lbs.
Pancake Batter	Whip or Beater	9 Qts.
Cookie Dough	Beater or Hook	14 lbs.
Donuts, Yeast	Hook	20 lbs.
Donuts, Cake	Beater	23 lbs.
Bread Dough (65% AR)	Hook	25 lbs.
Pizza Dough (50% AR)***	Hook	12 lbs.



Standard tools: Stainless Steel flat beater, wire whip, and dough hook.