

Food Bars

Children's

Models 6FBRSL - 6 ft. (182 cm), 5FBRSL - 5 ft. (162 cm)
4FBRSL - 4 ft. (130 cm)



Features & Benefits

- Versatility, style and durability for self-service breakfast, lunch or dinner. Accommodates GN 1/1 Full or Fractional Size Food Pans up to 6" (15 cm) deep with Divider Bars.
- Serving height is just 28" (71 cm) from the floor, perfect for children.
- Double-wall polyethylene construction provides extra strength, durability and reliability. Scratch-resistant textured exterior. Simple to clean - just wipe off.
- Thick foamed-in-place polyurethane insulation maintains food temperatures and holds ice cold for hours. Provides added structural strength.
- NSF listed threaded faucet drain with a standard hose hook-up provides quick draining and cleaning.
- Four each 5" (12,7 cm) swivel casters w/ brakes ensure easy maneuvering.
- Standard accessories include protective Sneeze Guard panel made from NSF listed material.
- Optional accessories include Tray Rails, End Tables, Divider Bars, Crock Holder, and Salad Bowl Holders.
- Non-electrical.
- Easy to assemble.
- Available in 15 colors.

Item No. _____

Specifier Identification No. _____

Model No. _____

Quantity _____



5FBRSL
(Shown with optional End Tables and Tray Rail)



Optional End Table FBRTBL

Set Up Guide for Children's Food Bars

Salad Bowls and Crock

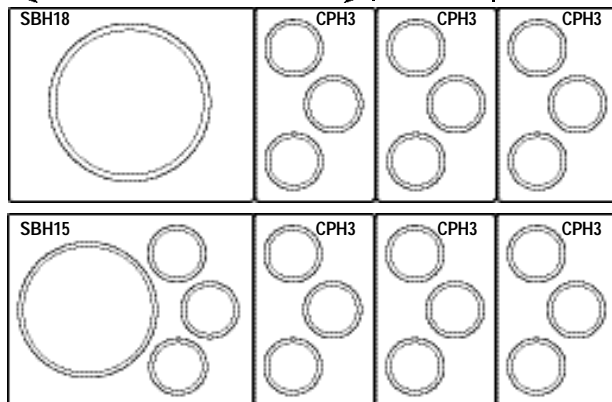
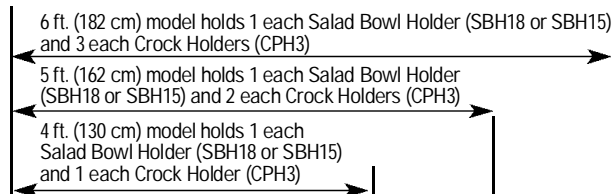

SBH18 - Holds 1 each 18" (45,7 cm) Salad Bowl
SBH15 - Holds 1 each 15" (38 cm) Salad Bowl & 3 each 1.5 qt. (1,4 L) or 2.7 qt. (2, 4 L) Crock
CPH3 - Holds 3 each 1.5 qt. (1,4 L) or 2.7 qt. (2, 4 L) Crock

Food Pans

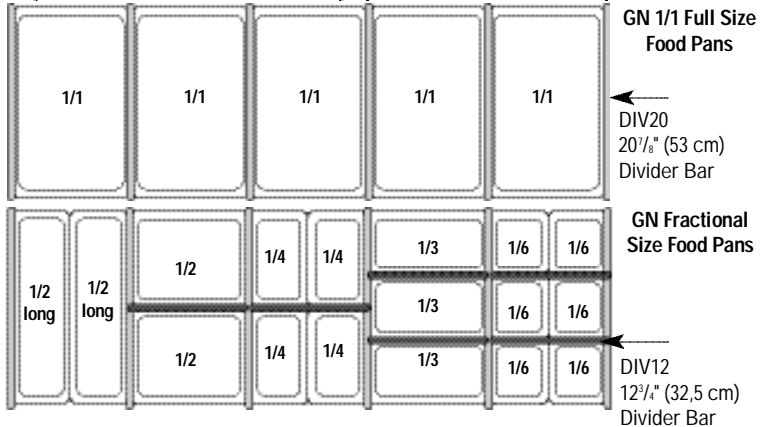
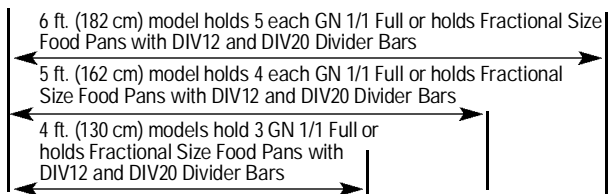

Approvals



Food Bars

Children's

Models 6FBRSL - 6 ft. (182 cm), 5FBRSL - 5 ft. (162 cm)
4FBRSL - 4 ft. (130 cm)

Item No. _____

Specifier Identification No. _____

Model No. _____

Quantity _____

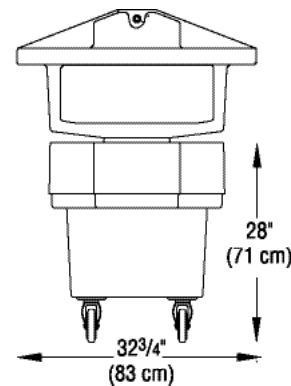
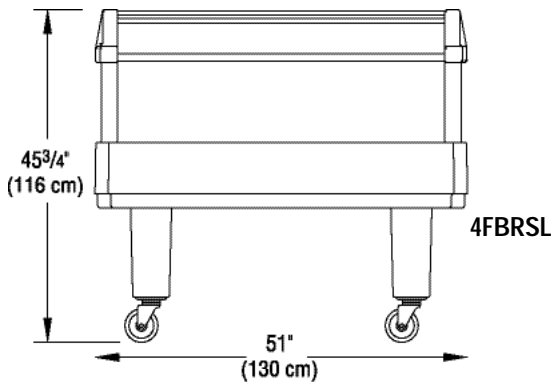
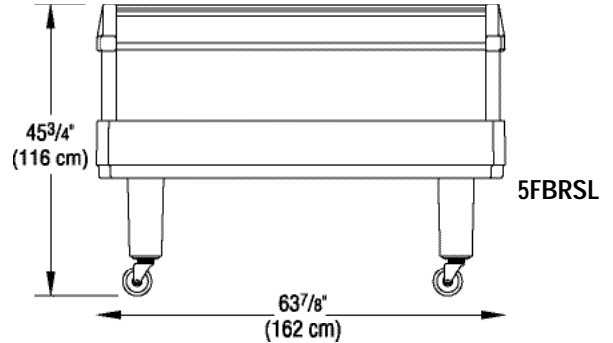
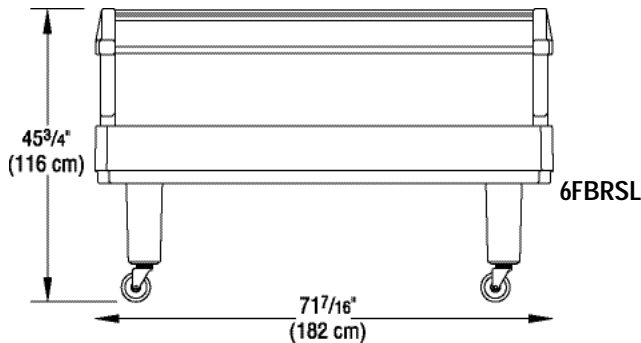

Specifications

Dimension Tolerance: +/- 1/4" (0,64 cm)

Code	Description	GN 1/1 Full Size Food Pan Capacity	Exterior Dimensions L x W x H	Case lbs./cube Kg/m ³
6FBRSL	6 ft. (182 cm) Children's Food Bar	5	71 7/16" x 32 3/4" x 45 3/4" (181 x 83 x 116 cm)	145 (28.56) 66 (0,8)
5FBRSL	5 ft. (162 cm) Children's Food Bar	4	63 7/8" x 32 3/4" x 45 3/4" (162 x 83 x 116 cm)	131 (25.62) 59,5 (0,72)
4FBRSL	4 ft. (130 cm) Children's Food Bar	3	51" x 32 3/4" x 45 3/4" (130 x 83 x 116 cm)	116 (25.62) 53 (0,72)

Optional Accessories

- Tray Rails**
- FBR6R (6 ft.) (182 cm)
 - FBR5R (5 ft.) (162 cm)
 - FBR4R (4 ft.) (130 cm)
- End Tables**
- FBRTBL
- 3-Crock Holder**
- CPH3 (holds 1.5 qt. (1,4 L) and 2.7 qt. (2,4 L) crocks)
- Salad Bowl Holders**
- SBH15 (holds one 15" (38 cm) bowl, 3 crocks)
 - SBH18 (holds one 18" (46 cm) bowl)
- Divider Bars**
- DIV12
 - DIV20

Standard Colors

- Black (110)
- Slate Blue (401)
- Brick Red (402)
- Coffee Beige (157)
- Dark Brown (131)
- Cold Blue (159)
- Navy Blue (186)
- Dusty Rose (400)
- Gray (180)
- Green (519)
- Hot Red (158)
- Granite Gray (191)
- Granite Green (192)
- Granite Red (193)
- Granite Sand (194)

Divider Bar:

- White (148)
- Clear (035)

Crock Holder and Salad Bowl Holder:

- White (148)

Architect Specs

The non-electrical portable foodservice Food Bar shall be a Floor Model Children's Food Bar, Model..., manufactured by Cambro Mfg. Co., Huntington Beach, CA 92648 U.S.A. It shall be made of double-wall polyethylene and foam-injected polyurethane insulation. It shall have a 28" (71 cm) working height from the floor to the top of the food wells. It shall have 4 each 5" (12,7 cm) swivel casters with brakes. It shall hold optional accessories such as the Cambro Salad Bowl Holders (SBH18 and SBH15) and Crock Holders (CPH3) or a selection of GN Full or Fractional Size Food Pans with Divider

Bars. The depth of the interior food wells shall be 6 1/2" (16,5 cm). It shall be available with optional end tables and side tray rails. It shall include a sneeze guard and protective end panels. It shall have an NSF Listed threaded faucet drain with a standard hose hook up. It shall be available in 15 colors.

Approvals

