

Camcarriers®

Top Loading

For GN Food Pans

Models 125MPC, 140MPC, 160MPC



Features & Benefits

- Rugged and dependable, these Camcarriers provide an exact fit for a wide variety of GN Full and Fractional Size Food Pans.
- Create a wide variety of service configurations for food transporting using Cambro's GN Fractional Food Pans and 12" (32,5 cm) Divider Bars. Easily transforms these Camcarriers into a mini food bar, salad bar or condiment station! (Refer to the Food Storage Pans and Boxes section in this catalog for a complete guide to Food Pans and set-up configurations.)
- GN 1/1 Full size Food Pan capacity:
 - Model 125MPC - 1 each 2½" (6,5 cm) deep
 - Model 140MPC - 1 each 4" (10 cm) deep
 - Model 160MPC - 1 each 6" (15 cm) deep
- One-piece seamless, double-wall, high-density polyethylene construction is durable, lightweight and dishwasher safe. Textured exterior is scratch resistant.
- Foamed-in polyethylene insulation and an airtight gasket helps to ensure excellent food temperature retention, hot or cold.
- Recessed vent cap located on the top is easily opened to help equalize pressure and release steam.
- Four each recessed plastic latches secure the lid tightly and will not rust or corrode and are protected from damage during use.
- Molded-in rim on all sides provides a comfortable grip for easy transporting.
- Securely stacks easily for more efficient transportation and storage. Models 140MPC and 160MPC also stack with Ultra Pan Carriers® and S-Series Ultra Pan Carriers®.
- Optional Camdolly® model CD160 provides easy transporting.
- Non-electrical.
- No assembly required.
- Available in 10 colors. Color variety offers quick food content identification and inventory control at-a-glance.

Item No. _____

Specifier Identification No. _____

Model No. _____

Quantity _____

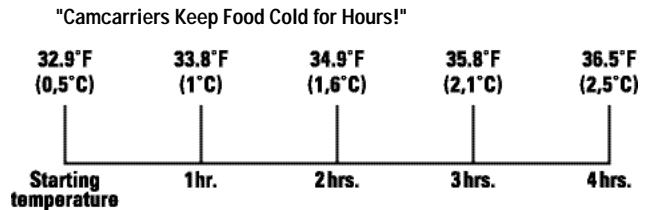
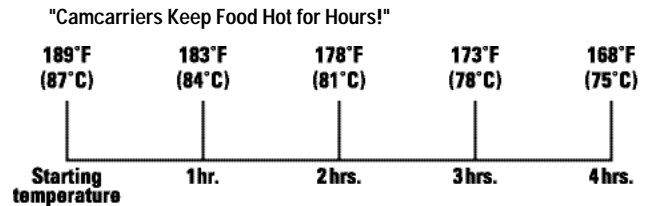

Approvals



Top Loading

For GN Food Pans

Models 125MPC, 140MPC, 160MPC

Quantity _____

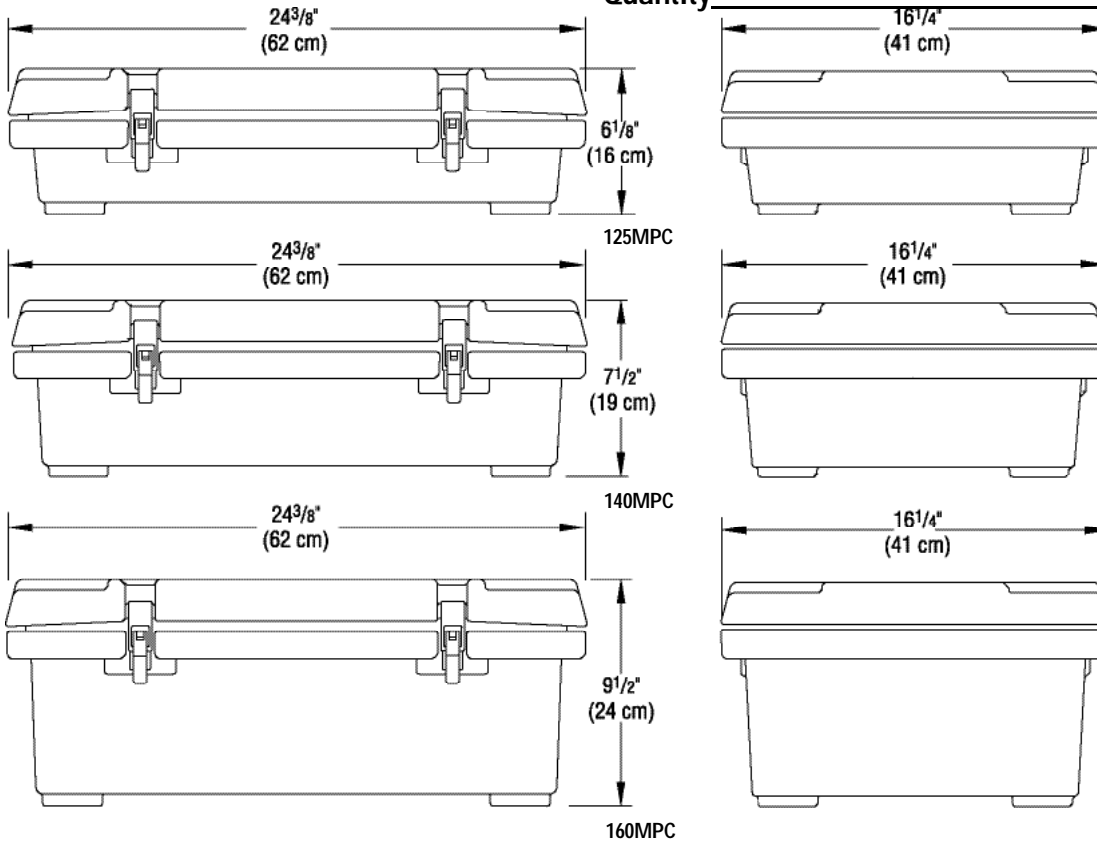

Specifications

Dimension Tolerance: +/- 1/4" (0,64 cm)

Code	Description	Approx. Capacity	Exterior dimensions L x W x H	Case lbs./cube Kg/m ³
125MPC	Camcarrier	6.7 qts. (7,6 L)	24 ³ / ₈ " x 16 ¹ / ₄ " x 6 ¹ / ₈ " (62 x 41 x 16 cm)	13.75 (1.53) 6,5 (0,043)
140MPC	Camcarrier	12.3 qts. (11 L)	24 ³ / ₈ " x 16 ¹ / ₄ " x 7 ¹ / ₂ " (62 x 41 x 19 cm)	15 (2.02) 7 (0,06)
160MPC	Camcarrier	20 qts. (17 L)	24 ³ / ₈ " x 16 ¹ / ₄ " x 9 ¹ / ₂ " (62 x 41 x 24 cm)	16.5 (2.52) 7,5 (0,07)

Optional Accessories

- Divider Bar** DIV12 White (148) Clear (135)
Camdolly® CD160

Standard Colors

- Dusty Rose (400) Navy Blue (186) Slate Blue (401)
 Cold Blue (159) Coffee Beige (157) Dark Brown (131)
 Brick Red (402) Green (519) Black (110)
 Hot Red (158)

Architect Specs

The portable non-electrical hot and cold GN Food Pan transport carriers shall be Camcarriers, Models 125MPC, 140MPC, 160MPC, manufactured by Cambro Mfg. Co., Huntington Beach, CA 92648 U.S.A. It shall be made of one-piece, seamless, double-wall, high-density polyethylene and foam-injected polyurethane. It shall have a recessed vent cap on the outside top cover to help equalize pressure and release steam. It shall have an airtight gasket that is easily removable for cleaning. It shall be available to transport GN Full and Fractional size Food Pans, 2 1/2", 4" and 6" (6,5; 10; and 15 cm) deep with DIV12

Divider Bars. It shall have 4 each recessed plastic latches. It shall have a molded-in rim on all sides for transporting. It shall have an interlock design on the bottom and top corners to provide secure stacking for transport and storage. It shall be transportable with optional Camdollies®. It shall require no assembly and shall be available in 10 colors.

Approvals

