

AR-7E ELECTRIC ROTISSERIE



- Cook and hold in a single, counter-top rotisserie that features a combination of convection and radiant heat.
- A choice of one or two cooking stages for an improved finished product.
- Solid state electronic control has a clear, easy-to-read LED display to cook by time and features an automatic temperature reduction to a holding mode where product can remain until needed.
- Programmable control option with a seven program memory for both the cooking and holding function.
- Single pane low-e glass is easy to clean and maximize merchandising appeal while conserving heat loss.
- The rotisserie can be stacked with an identical rotisserie oven or with a matching holding cabinet.
- Interior drip strips channel drippings into a bottom drip pan for convenient removal.
- Spits, rotating disks, drip strips are also removable for easy cleaning.
- Interior lighting is recessed to protect from breakage.

The Alto-Shaam electric rotisserie is constructed of a heavy gauge, non-magnetic stainless steel with a sealed cooking chamber for heat retention. Single pane, low-e glass on both front and back includes a control-side handle with magnetic door latch. Spit rotation is controlled by one (1) 1/2 hp motorized disk that provides an incremental rotation jog and automatic stop when door is opened. The cook temperature range is from 250° to 425°F (121° to 218°C). Additional electronic control features include temperature display in Fahrenheit or Celsius; a product hold key with a temperature range of 140° to 210°F (60° to 99°C), cooking set-points from 1 minute to 4 hours; and emergency stop.

The rotisserie has a stainless steel exterior finish and is furnished with 4-inch legs.

Deluxe control option includes a programmable control with seven-program memory.

MODEL AR-7E: Electric Rotisserie Oven

MODEL AR-7E DELUXE: Electric Rotisserie Oven with Programmable Menu Memory Control

ADDITIONAL FEATURES & OPTIONS

- Optional double pane doors with curved glass exterior adds styling and provides free-flowing air space between panes to further reduce heat loss.
- Optional handle on non-control side for pass-through use.
- Optional programmable control lets the operator set up to seven cooking programs for both cooking and holding functions.
- Multipurpose wire basket option handles irregular size products, denser items, or heavier products that require additional support.
- A rotisserie-mounted Ventless Hood option eliminates the need for costly ventilation or oven hood space.
- Choose from the standard stainless steel finish or an optional powdered coated stainless in a choice of colors.



ANSI/NSF 4



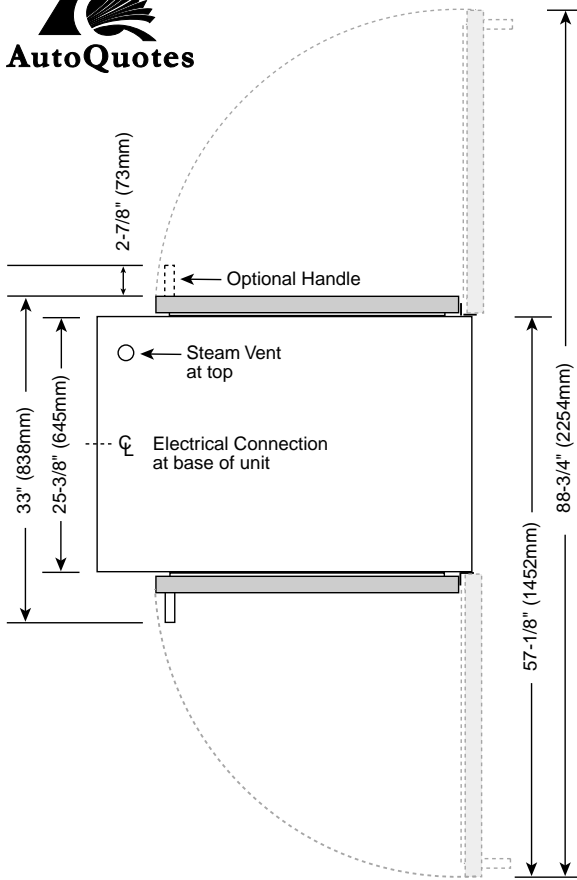

DIMENSIONS: H x W x D
EXTERIOR: 36-11/16" x 37-15/16" x 35-7/8" (932mm x 964mm x 911mm)

ELECTRICAL					
VOLTAGE	PHASE	CYCLE/HZ	AMPS	kW	
208	1	50/60	40.0	8.3	
230	1		37.0	8.3	NO PLUG
240	1		38.0	8.8	
208	3	50/60	33.0/ph	8.3	
230	3		33.0/ph	8.3	NO PLUG
240	3		32.0/ph	8.8	
380/415	3		22.0/ph	8.8	NO CORD NO PLUG

INSTALLATION REQUIREMENTS
<ul style="list-style-type: none"> Oven must be installed level. Exhaust ventilation is required Install on a non-combustible surface only The oven must not be installed in any area where it may be affected by steam, grease, dripping water, high temperatures, or any other severely adverse conditions. In order to maintain NSF standards, counter models must be sealed at the bottom by an NSF approved sealant or equipped with 4" (102mm) legs.

CLEARANCE REQUIREMENTS
6" (152mm) left, right, and rear sides

STANDARD ACCESSORIES
<ul style="list-style-type: none"> Seven (7) removable stainless steel angled spits One (1) removable stainless steel drip pan, 2" (51mm) deep Two (2) removable stainless steel angled drip strips Six (6) 20 watt recessed bulbs

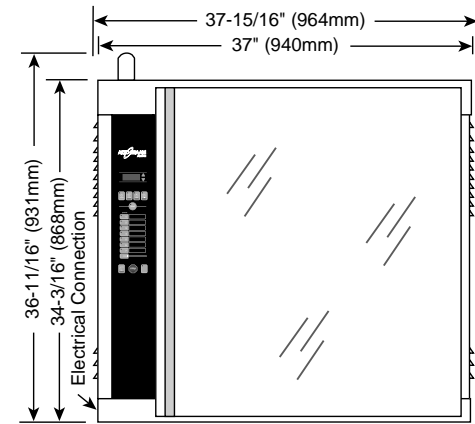

NOTE — HEIGHT DIMENSION VARIANCE:
 4" (102mm) legs add 4-3/8" (111mm)
 5" (127mm) casters add 6-3/8" (162mm)
 6" (152mm) legs add 6-3/8" (162mm)

PRODUCT CAPACITY	WEIGHT
98 lb (44 kg) MAXIMUM	NET: 361 lb (164 kg)
ANGLED SPITS (STANDARD): Up to twenty-one (21) 3-1/2 lb chickens (1,6 kg) Up to twenty-eight (28) 2-1/2 to 3 lb chickens (1,1 to 1,4 kg)	SHIP: 540 lb (245 kg)
PIERCING SPITS (OPTIONAL): Up to twenty-eight (28) 2-1/2 to 3-1/2 lb chickens (1,1 to 1,6)	CRATE DIMENSIONS: 49" x 50" x 45" EST. (1245mm x 1270mm x 1143mm) (H x W x D)

ELECTRIC ROTISSERIE **AR-7E**

OPTIONS & ACCESSORIES	
<input type="checkbox"/> Casters, 5" (127mm)	4007
Custom Panel Colors	
<input type="checkbox"/> Black	5001331
<input type="checkbox"/> Burgundy	5002955
<input type="checkbox"/> Custom Color	CONTACT FACTORY
Door, Double Pane Curved Glass	
<input type="checkbox"/> With Handle	5001202
<input type="checkbox"/> Without Handle	5001075
<input type="checkbox"/> Door Handle (FOR SINGLE PANE GLASS DOOR ON NON-CONTROL SIDE)	HD-26900
<input type="checkbox"/> Drip Pan with drain	5001094
Legs	
<input type="checkbox"/> Legs, 6" (152mm) Assembly	5001414
<input type="checkbox"/> Legs, 6" (152mm) Assembly, flanged feet	5001761
<input type="checkbox"/> Multi-Purpose Wire Basket (.50 dia. pin)	BS-26019
Spits	
<input type="checkbox"/> Angled Spit, Stainless Steel	SI-25934
<input type="checkbox"/> Piercing Spit, Stainless Steel	SI-25729
Stacking Assembly	
<input type="checkbox"/> AR-7E over AR-7E	5001479
<input type="checkbox"/> AR-7E over AR-7H	NONE REQUIRED
Stand, Stainless Steel	
<input type="checkbox"/> With Storage Shelf	5002057
<input type="checkbox"/> Open (AR-7E over 750-S or 6•10iN/ML)	5002058
Teflon® Coated Accessories - COMMERCIAL GRADE	
<input type="checkbox"/> Items purchased separately	CONTACT FACTORY
<input type="checkbox"/> Ventless Hood, FACTORY INSTALLATION ONLY	AR-7VH*

***SEE BACK PAGE FOR COMPLETE SPECIFICATIONS ON THE VENTLESS HOOD.**

STACKING COMBINATION

AR-7VH VENTLESS HOOD OVER
AR-7E ROTISSERIE OVER
AR-7H COMPANION HOLDING CABINET



STACKING COMBINATIONS

AR-7VH ventless hood *over* AR-7E rotisserie

Requires 4" (102mm) legs for counter top applications. Free standing floor installations require 6" (152mm) leg assembly **5001414** or 5" (127mm) casters **4007**.

HxWxD = 54-5/16" x 37-15/16" x 34-7/8" (1380 x 964 x 885mm)

AR-7E rotisserie *over* AR-7E rotisserie

Requires 6" (152mm) leg assembly **5001414** or 5" (127mm) casters **4007** and stacking assembly **5001479** for applications within the United States. Applications outside the U.S. requires 6" (152mm) legs with flanged feet **5001761** bolted to the floor.

HxWxD = 77-1/4" x 37-15/16" x 34-7/8" (1962 x 964 x 885mm)

AR-7E rotisserie *over* AR-7H companion holding cabinet

Requires 6" (152mm) leg assembly **5001414** or 5" (127mm) casters **4007** for applications within the United States. Applications outside the U.S. requires 6" (152mm) legs with flanged feet **5001761** bolted to the floor.

HxWxD = 77-1/4" x 37-15/16" x 34-7/8" (1962 x 964 x 885mm)

AR-7VH ventless hood *over* AR-7E rotisserie *over* AR-7H companion holding cabinet

Requires 6" (152mm) legs with flanged feet **5001761** bolted to the floor.

HxWxD = 90-1/2" x 37-15/16" x 34-7/8" (2299 x 964 x 885mm)



W164 N9221 Water Street • PO Box 450 • Menomonee Falls, Wisconsin 53052-0450 • U.S.A.
PHONE: 262.251.3800 • 800.558.8744 U.S.A./CANADA FAX: 262.251.7067 • 800.329.8744 U.S.A. ONLY
WEBSITE: www.alto-shaam.com



AR-7VH VENTLESS HOOD
INSTALLED DIRECTLY ON THE TOP OF
ELECTRIC ROTISSERIE MODEL AR-7E

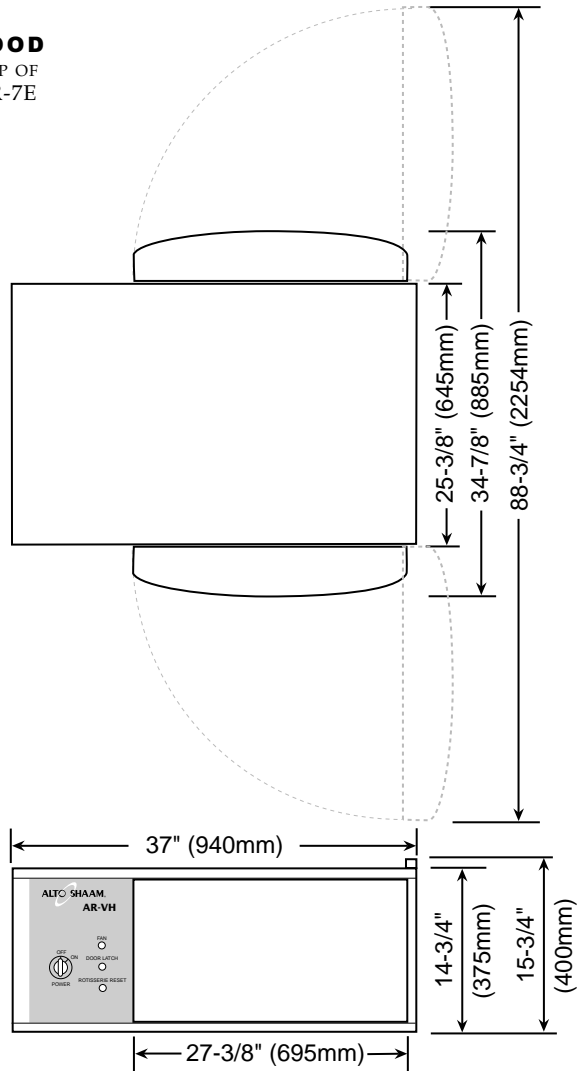

LISTED
COOKING APPLIANCE
WITH INTEGRAL SYSTEMS
FOR LIMITING THE EMISSION
OF GREASE LADEN AIR
1P35

ALSO CLASSIFIED BY
UNDERWRITERS
LABORATORIES INC.®
IN ACCORDANCE WITH
NSF4 - 2002

DIMENSIONS: H x W x D
15-3/4" x 37" x 34-7/8"
(400mm x 940mm x 885mm)

ELECTRICAL				
VOLTAGE	PHASE	CYCLE/HZ	AMPS	kW
208-240	1	50/60	1.0	.2

AIR MOVEMENT
530 cfm (15m ³)

INSTALLATION REQUIREMENTS
FACTORY INSTALLATION ONLY The ventless hood must not be installed in any area where it may be affected by steam, grease, dripping water, high temperatures, or any other severely adverse conditions.

CLEARANCE REQUIREMENTS
6" (152mm) left, right, and rear sides

OPTIONS & ACCESSORIES	
Replacement Filters	
<input type="checkbox"/> Grease Filter	FI-25867
<input type="checkbox"/> Charcoal Filter	FI-25866

WEIGHT
NET: 120 lb (54 kg)
SHIP: 175 lb (79 kg) ADDITIONAL SHIP WEIGHT
FACTORY INSTALLED OVER AR-7E ROTISSERIE
CRATE DIMENSIONS: 62" x 50" x 45" EST. (1575mm x 1270mm x 1143mm) (H x W x D)