

# Electrolux

## Modular Cooking Range Line S90 Heavy Duty One Well Gas Deep Fat Fryer, C-Board

ITEM # \_\_\_\_\_

MODEL # \_\_\_\_\_

PROJECT NAME # \_\_\_\_\_

SIS # \_\_\_\_\_

AIA # \_\_\_\_\_



### Modular Cooking Range Line S90 Heavy Duty One Well Gas Deep Fat Fryer, C-Board

584101 S90 ONE 6 GAL WELL GAS DEEP FAT FRYER,  
CB, ONE SIDE OPERATION

### Short Form Specification

Item No. \_\_\_\_\_

Unit to be Electrolux S90 Heavy Duty One 6 gal well Gas Deep Fat Fryer. Unit to have high efficiency 74,000 BTU (22 kW) burners. Unit to have deep drawn V-Shaped well with expansion zone located at top of the well. Oil cleaning device shall be located below the well. Unit to have raised rear c-board for against the wall or back to back unit installation. Body and base of unit entirely in 304 type Stainless steel. Unit shall have heavy duty 304 type Stainless steel internal frame with reinforcement on the top of 0.118" (3 mm). Extra strength work top in heavy duty 0.118" (3 mm) Stainless steel. "Lasertec" connection system permits units to be connected to each other creating a seamless work top.

Covered by Electrolux Platinum Star™ Service Program two-year parts and one-year labor warranty, installation start-up and performance check-up after one year from installation.



Approval: \_\_\_\_\_

### Main features

- Deep drawn "V"-Shaped well.
- Interior of well with rounded corners for easy of cleaning.
- External heating elements for ease of cleaning of internal well.
- High efficiency 74,000 btu (22 kW) burners.
- Expansion zone located on top of the well.
- Thermostatic regulation of oil temperature up to a maximum of 365 °F (185 °C)
- Flame failure device to each burner.
- Overheat protection as standard on all units.
- Oil cleaning device located in compartment below the well.
- All major compartments located in front of unit for ease of maintenance.
- Piezo spark ignition with thermocouple for added safety.
- Heavy duty internal frame 304 type Stainless steel with reinforcement on top of 0.118" (3 mm).
- 0.118" (3 mm) top in 305 type Stainless steel.
- "Lasertec connection system" creates seamless work top when units are connected to each other.
- Raised rear C-Board permits unit to be connected up against the wall for better hygiene.
- Unit delivered with four 7-7/8" (200 mm) legs as standard (all round Stainless steel kick plates as option).
- Supplied as standard with 2 baskets with insulated handles.

### Included accessories

- Basket rest grid for 6 gal well fryer.
- 2 baskets for 6 gal fryer.
- Closing cover for 6 gal fryer.

### Optional Accessories

- Left side Stainless steel 0.118" (3 mm) panel.
- Right side Stainless steel 0.118" (3 mm) panel.
- 5" (130 mm) Portioning Shelf.
- 7.8" (200 mm) Portioning Shelf.
- All round Stainless steel kick plates.
- Basket rest grid for 6 gal well fryer (included).
- Discharge vessel for 6 gal fryer.
- Lid for discharge vessel for 6 gal fryer.
- Extra basket for 6 gal fryer (two included).
- Closing cover for 6 gal fryer (included).
- Oil strainer for fryer.
- Sediment tray for fryers.



# Electrolux

S90 Heavy Duty One Well Gas Deep Fat Fryer, C-Board  
Modular Cooking Range Line

**Electrolux Professional, Inc.**

[www.electroluxusa.com/professional](http://www.electroluxusa.com/professional)

3225 SW 42nd Street, Fort Lauderdale, Florida, 33312 • Telephone Number: 866-449-4200 • Fax Number: 954-327-6789

**Front View**

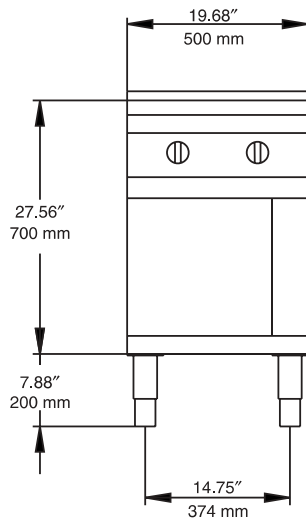

**Top View**

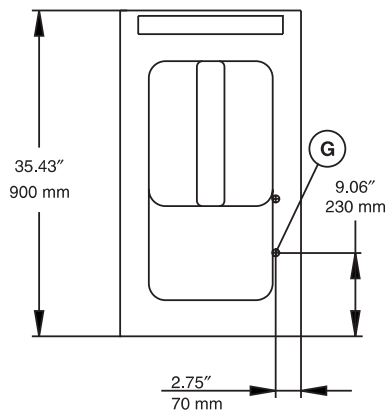

**G** = Gas connection

**Side View**

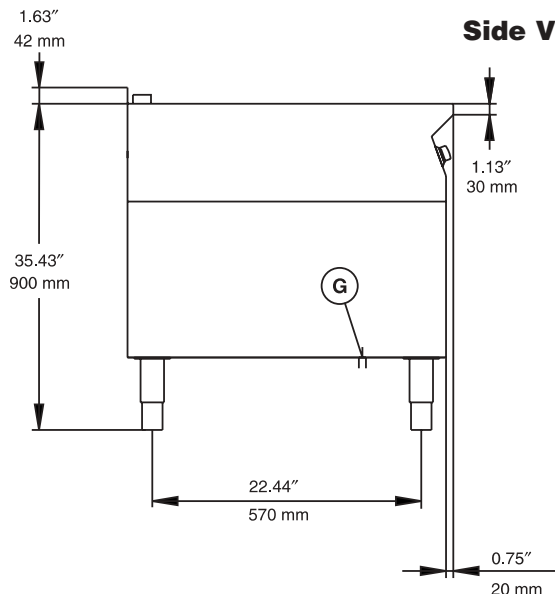

### Gas

|                              |  |
|------------------------------|--|
| <b>Gas Power:</b>            | 74,000 Btu/hr (22 kW)  |
| <b>Gas Type Option:</b>      | Butane, Natural Gas, Propane<br>(must be specified when ordered) |
| <b>Natural Gas Pressure:</b> | 7" w.c. (17.7 mbar)  |
| <b>LPG Gas Pressure:</b>     | 11" w.c. (27.7 mbar)   |
| <b>Gas Inlet:</b>            | 3/4" NPT   |

### Key Information

|   |  |
|---|--|
| <b>Usable well dimensions (width):</b>  | 13-3/8" (340 mm)                                     |
| <b>Usable well dimensions (height):</b> | 22-5/8" (575 mm)                                     |
| <b>Usable well dimensions (depth):</b>  | 15-3/4" (400 mm)                                     |
| <b>Well capacity:</b>                   | 5.55 gal (21 liters) MIN<br>6.08 gal (23 liters) MAX |
| <b>Thermostat Range:</b>                | 221 °F (105°C) MIN<br>365 °F (185°C) MAX             |
| <b>Net weight:</b>                      | 220 lb (100 kg)                                      |
| <b>Shipping weight:</b>                 | 265 lb (120 kg)                                      |
| <b>Shipping width:</b>                  | 27-9/16" (700 mm)                                    |
| <b>Shipping height:</b>                 | 43-5/16" (1100 mm)                                   |
| <b>Shipping depth:</b>                  | 43-5/16" (1100 mm)                                   |
| <b>Shipping volume:</b>                 | 30.01 cu.ft (0.85 m3)                                |

If appliance is set up or next to or against temperature sensitive furniture or similar, a safety gap off approximately 6" (150 mm) should be maintained or some form of heat insulation fitted.