

Electrolux

Modular Cooking Range Line S90 Heavy Duty One Well Electric Deep Fat Fryer, C-Board

ITEM # _____

MODEL # _____

PROJECT NAME # _____

SIS # _____

AIA # _____



Modular Cooking Range Line S90 Heavy Duty One Well Electric Deep Fat Fryer, C-Board

584093 S90 ONE 6 GAL WELL ELECTRIC
DEEP FAT FRYER, CB, ONE SIDE OPERATION
208 V

584094 S90 ONE 6 GAL WELL ELECTRIC
DEEP FAT FRYER, CB, ONE SIDE OPERATION
208 V

Short Form Specification

Item No. _____

Unit to be Electrolux S90 Heavy Duty One 6 gal well Electric Deep Fat Fryer. Electric characteristics to be _____208 V or _____240 V three phase. Unit to have deep drawn V-Shaped well with expansion zone located at top of the well. Oil cleaning device shall be located below the well. Unit to have raised rear c-board for against the wall or back to back unit installation. Body and base of unit entirely in 304 type Stainless steel. Unit shall have heavy duty 304 type Stainless steel internal frame with reinforcement on the top of 0.118" (3 mm). Extra strength work top in heavy duty 0.118" (3 mm) Stainless steel. "Lasertec" connection system permits units to be connected to each other creating a seamless work top.

Covered by Electrolux Platinum Star™ Service Program two-year parts and one-year labor warranty, installation start-up and performance check-up after one year from installation.



Approval: _____

Main features

- Deep drawn V-Shaped well.
- Interior of well with rounded corners for easy of cleaning.
- External heating elements for ease of cleaning of internal well.
- Expansion zone located on top of the well.
- Thermostatic regulation of oil temperature up to a maximum of 365 °F (185 °C)
- Overheat protection as standard on all units.
- Oil cleaning device located in compartment below the well.
- All major compartments located in front of unit for ease of maintenance.
- Heavy duty internal frame 304 type Stainless steel with reinforcement on top of 0.118" (3 mm).
- 0.118" (3 mm) top in 305 type Stainless steel.
- "Lasertec connection system" creates seamless work top when units are connected to each other.
- Raised rear C-Board permits unit to be connected up against the wall for better hygiene.
- Unit delivered with four 7-7/8" (200 mm) legs as standard (all round Stainless steel kick plates as option).
- Supplied as standard with 2 baskets with insulated handles.

Accessories

- Basket rest grid for 6 gal well fryer.
- 2 baskets for 6 gal fryer.
- Closing cover for 6 gal fryer.

Optional Accessories

- Left side Stainless steel 0.118" (3 mm) panel.
- Right side Stainless steel 0.118" (3 mm) panel.
- 5" (130 mm) Portioning Shelf.
- 7.8" (200 mm) Portioning Shelf.
- All round Stainless steel kick plates.
- Basket rest grid for 6 gal well fryer (included).
- Discharge vessel for 6 gal fryer.
- Lid for discharge vessel for 6 gal fryer.
- Extra basket for 6 gal fryer (two included).
- Closing cover for 6 gal fryer (included).
- Oil strainer for fryer.
- Sediment tray for fryers.



Electrolux

Modular Cooking Range Line
S90 Heavy Duty One Well Electric Deep Fat Fryer, C-Board

Electrolux Professional, Inc.
www.electroluxusa.com/professional

3225 SW 42nd Street, Fort Lauderdale, Florida, 33312 • Telephone Number: 866-449-4200 • Fax Number: 954-327-6789

Front View

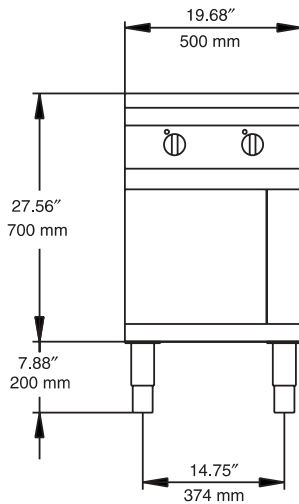

Top View

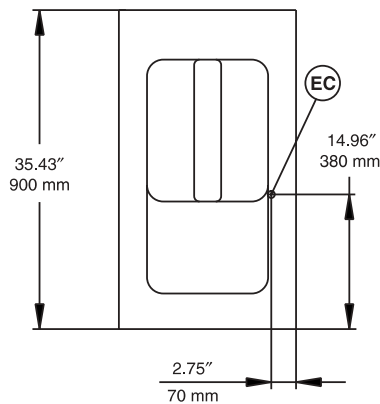

EC = Electrical connection

Side View

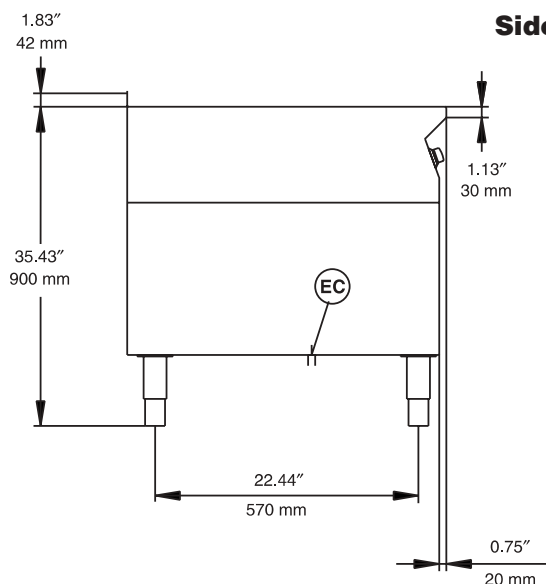

Electric

Supply voltage:

584093 208 V/3p/60Hz - 40A

584094 240 V/3p/60Hz - 39A

Total Watts:

584093 12.2 kW

584094 13 kW

Key Information

Usable well dimensions

(width): 13-3/8" (340 mm)

Usable well dimensions

(height): 22-5/8" (575 mm)

Usable well dimensions

(depth): 15-3/4" (400 mm)

Well capacity:

5.55 gal (21 liters) MIN

6.08 gal (23 liters) MAX

Thermostat Range:

221 °F (105 °C) MIN

365 °F (185 °C) MIN

Net weight:

198 lb (90 kg)

Shipping weight:

243 lb (110 kg)

Shipping width:

27-9/16" (700 mm)

Shipping height:

43-5/16" (1100 mm)

Shipping depth:

43-5/16" (1100 mm)

Shipping volume:

30.01 cu.ft (0.85 m³)

If appliance is set up or next to or against temperature sensitive furniture or similar, a safety gap off approximately 6" (150 mm) should be maintained or some form of heat insulation fitted.