

Electrolux

Modular Cooking Range Line S90 Heavy Duty Full Module Gas Char-Broiler, Open Base, C-Board

ITEM # _____

MODEL # _____

PROJECT NAME # _____

SIS # _____

AIA # _____



Modular Cooking Range Line S90 Heavy Duty Full Module Gas Char-Broiler, Open Base, C-Board

584091 S90 FULL MODULE GAS CHAR-BROILER,
OPEN BASE, CB, 1SIDE OPERATION

Short Form Specification

Item No. _____

Unit to be Electrolux S90 Heavy Duty Full Module Gas Char-Broiler with open base. Unit to have high efficiency 82,000 BTU (24 kW) Stainless steel burners with self stabilizing flame. Cooking surface grids to be of cast iron, easily removable for cleaning. Cast iron grids can be rotated for the grilling of fish or meats. Unit to have raised rear c-board for against the wall or back to back unit installation. Unit to include drip tray for the collection of grease and fat. Body and open base of unit entirely in 304 type Stainless steel and basin made of high grade 316 type Stainless steel. Unit shall have heavy duty 304 type Stainless steel internal frame with reinforcement on the top of 0.118" (3 mm). Extra strength work top in heavy duty 0.118" (3 mm) Stainless steel. "Lasertec" connection system permits units to be connected to each other creating a seamless work top.

Covered by Electrolux Platinum Star™ Service Program two-year parts and one-year labor warranty, installation start-up and performance check-up after one year from installation.

Main features

- 304 type Stainless steel burners with self stabilizing flame.
- Each burner has 3 branches and the gas holes are protected by the radiant elements to prevent fat dripping on them.
- Regulators with fixed high and low positions for precise control.
- Cast iron cooking grid lifts off for ease of cleaning.
- Cast iron grids can be rotated for grilling of fish or meats.
- Drip tray to collect residual cooking grease and fat.
- Stainless steel high splash guards on the rear and sides. Splash guards can be easily removed for cleaning.
- Open base compartment for storage of pots, pans sheet pans etc.
- Piezo spark ignition with thermocouple for added safety.
- Heavy duty internal frame 304 type Stainless steel with reinforcement on top of 0.118" (3 mm).
- Basin made of high grade 316 type Stainless steel.
- 0.118" (3 mm) top in 305 type Stainless steel.
- "Lasertec connection system" creates seamless work top when units are connected to each other.
- Raised rear C-Board permits unit to be connected up against the wall for better hygiene.
- Unit delivered with four 7-7/8" (200 mm) legs as standard (all round stainless steel kick plates as option).
- Scraper for cleaning of grilling grids included.

Optional Accessories

- Set 4 Castors (2 with brake)
- Left side Stainless steel 0.118" (3 mm) panel
- Right side Stainless steel 0.118" (3 mm) panel
- 5" (130 mm) Portioning Shelf
- 7.8" (200 mm) Portioning Shelf
- All round Stainless steel kick plates.
- Shelf for open base
- Shelf fixation kit for open base



Approval: _____

Electrolux Professional, Inc.

www.electroluxusa.com/professional

3225 SW 42nd Street, Fort Lauderdale, Florida, 33312 • Telephone Number: 866-449-4200 • Fax Number: 954-327-6789



Electrolux

Modular Cooking Range Line
S90 Heavy Duty Full Module Gas Char-Broiler, Open Base, C-Board



Modular Cooking Range Line S90 Heavy Duty Full Module Gas Char-Broiler, Open Base, C-Board

Front View

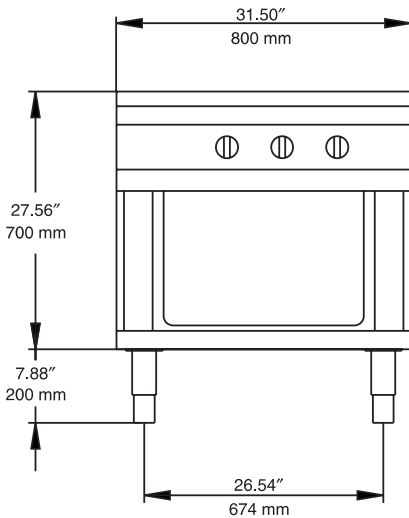

Top View

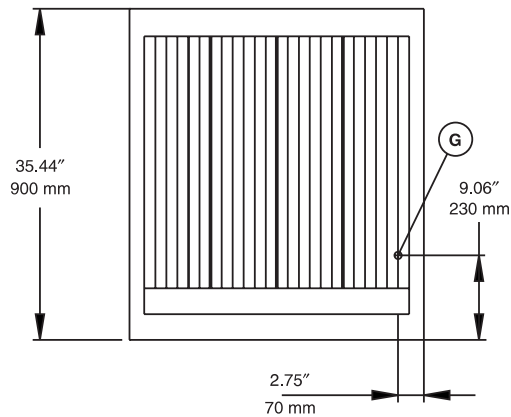

G = Gas connection

Side View

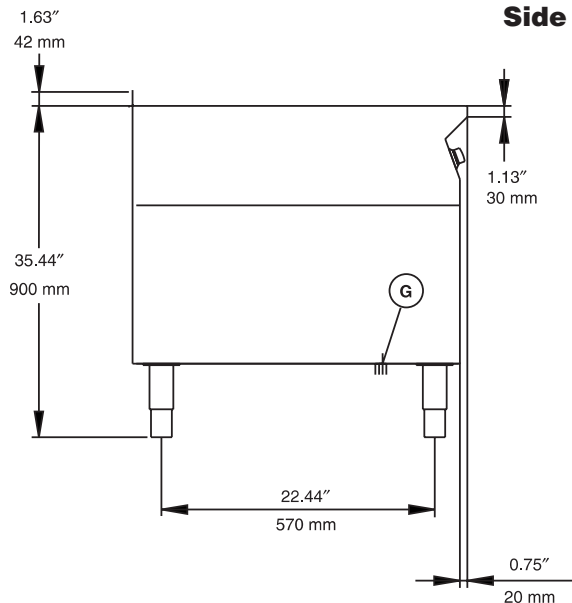

Gas

Gas Power:	82,000 Btu/hr (24 kW)
Gas Type Option:	Butane, Natural Gas, Propane (must be specified when ordered)
Natural Gas Pressure:	7" w.c. (17.7 mbar)
LPG Gas Pressure:	11" w.c. (27.7 mbar)
Gas Inlet:	3/4" NPT

Key Information

Storage Cavity Dimensions (width):	21-7/16" (544 mm)
Storage Cavity Dimensions (height):	14-1/16" (358 mm)
Storage Cavity Dimensions (depth):	29-1/16" (738 mm)
Net weight:	397 lb (180 kg)
Shipping weight:	441 lb (200 kg)
Shipping width:	39-3/8" (1000 mm)
Shipping height:	43-5/16" (1100 mm)
Shipping depth:	43-5/16" (1100 mm)
Shipping volume:	42.7 cu.ft (1.21 m ³)

If appliance is set up or next to or against temperature sensitive furniture or similar, a safety gap off approximately 6" (150mm) should be maintained or some form of heat insulation fitted.

Modular Cooking Range Line
S90 Heavy Duty Full Module Gas Char-Broiler, Open Base, C-Board

The company reserves the right to make modifications to the products without prior notice. All information correct at time of printing.

5-04-06