



**Warewashing**  
**44" Single Tank Conveyor Dishwasher**  
**w/o built in hot water booster WT44**

ITEM # \_\_\_\_\_  
 MODEL # \_\_\_\_\_  
 PROJECT NAME # \_\_\_\_\_  
 SIS # \_\_\_\_\_  
 AIA # \_\_\_\_\_



**Warewashing**  
**44" Single Tank Conveyor Dishwasher**  
**without built in hot water booster WT44**

- 534074 (WT44CL208) 44" Conveyor Dishwasher without Built in Booster. Left to Right - 208V
- 534075 (WT44CR208) 44" Conveyor Dishwasher without Built in Booster. Right to Left - 208V
- 534076 (WT44CL240) 44" Conveyor Dishwasher without Built in Booster. Left to Right - 240V
- 534077 (WT44CR240) 44" Conveyor Dishwasher without Built in Booster. Right to Left - 240V

**Short Form Specification**

Item No. \_\_\_\_\_

Unit to be Electrolux WT44 Hot Water Sanitizing 44" conveyor dishwasher without built in hot water booster. Electrical characteristics to be \_\_\_\_\_ 208 V or \_\_\_\_\_ 240 V three phase operation. Unit to operate from \_\_\_\_\_ left to right or \_\_\_\_\_ right to left. Unit to feature built in rinse booster pump thus guaranteeing rinse pressure during rinse cycle. Unit to have two conveyor speeds which can be selected from the control panel by the operator, 130 racks/hour or a maximum 200 racks/hour. Maximum water consumption at 200 racks/hour of only 79 gal/hour (0.4 gal/rack). Unit to feature large heat and noise insulated front counter balanced door for easy access of internal components. Powerful 2 HP wash pump and specially designed wash spray arms guaranteed cleaning. Unit to feature as standard end of day self cleaning cycle. Drain of water from the machine can be done through the control panel. Large deep drawn 26 gal wash tank.

Covered by Electrolux Platinum Star™ Service Program two-year parts and one-year labor warranty, installation start-up and performance check-up after one year from installation.

**Main features**

- Built in rinse booster pump guarantees constant rinse pressure.
- Speed of conveyor can be set through the control panel by the operator. 130 racks/hr or 200 racks/hr.
- Large counter balanced inspection doors allow unrestricted all round access to the wash and rinse area. Door is insulated with injected foam. This adds strength as well as reduces noise and heat loss.
- Large filters sloping towards the front to the smaller pressed filter box for quick removal. Filters feature holes smaller than the concave ant-block wash nozzles so large food cannot enter and block the wash system.
- Adjustable feet for full access underneath the machine for cleaning.
- Push button self cleaning cycle of the wash and rinse zones for ease of "end of day" cleaning.
- Wash chamber without internal pipes and therefore no hidden dirt traps.
- Self draining wash pumps provide maximum hygiene with no smells and all wash and rinse zones drain automatically at the push of a button.
- Powerful 2 Hp wash pump.
- Heavy duty Stainless steel wash pump (impeller and housing).
- Deep drawn pressed 26 gal wash tank with fully rounded corners, sloped towards the drain to prevent dirt build up provides fast drainage in only a few minutes. Pressed wash tank with no welded points offer a guaranteed water tight solution.
- Dishwasher structure is held together with a solid 2" x 2" Stainless steel tube sub-frame to provide long term sturdiness.
- All main components made in heavy duty anti-corrosive 304 type Stainless steel: tanks, panels, wash & rinse arms and caps, doors, front, handle, rear and side-panels and rack transportation system.
- Wash and rinse arms can be easily removed for cleaning.
- IPX5 (NEMA4) water protection ensures no damage from cleaning.
- Autostart/stop ensures that the machine runs only when a rack is passing through it. This reduces both water and energy consumption.
- Internal curtains made of silastic material and are not affected by detergent or heat.
- Electronic control panel features large display for reading of wash and rinse temperatures.
- Low water consumption. At 200 racks per hour, the machine uses only 79 gal/hr (0.4 gal/rack).
- Machine predisposed for external detergent and rinse aid connections.

**Included Accessories**

- Vent cowls (left and right side)
- One open sided dishwasher rack for trays
- Rack for cups.
- Rack for dinner plates.

**Optional Accessories**

- Ventilation activation kit
- Drain water tempering kit



Approval: \_\_\_\_\_

**Electrolux Professional, Inc.**  
 www.electroluxusa.com/professional

3225 SW 42nd Street, Fort Lauderdale, Florida, 33312 • Telephone Number: 866-449-4200 • Fax Number: 954-327-6789

**Electrolux**  
 44" Single Tank Conveyor Dishwasher without built in hot water booster  
 Warewashing  
 WT44



# Warewashing 44" Single Tank Conveyor Dishwasher without built in hot water booster WT44

## Electric

<b>Supply voltage:</b>	<b>534074</b> (WT44CL208)	208 V/3p/60Hz
	<b>534075</b> (WT44CR208)	208 V/3p/60Hz
	<b>534076</b> (WT44CL240)	240 V/3p/60Hz
	<b>534077</b> (WT44CR240)	240 V/3p/60Hz

Machine requires one electrical connection.

<b>Max. Current absorbed:</b>	208 V/3p/60Hz	61.7A (20.7 kW)
	240 V/3p/60Hz	55A (20.7 kW)

## Water

<b>Inlet Water supply pressure:</b>	22 – 102 psi (150 – 700 kPa)
<b>Inlet Water supply temperature</b>	
<b>Rinse circuit:</b>	194 °F (90 °C)
<b>Wash tank:</b>	80 – 140 °F (27 – 60 °C)
<b>Inlet Water supply hardness:</b>	4 – 8 gpg (7-14 °fH) max
<b>Incoming water line size:</b>	
<b>Wash tank:</b>	G 3/4"
<b>Rinse circuit:</b>	G 3/4"
<b>Drain line size:</b>	1-1/2"
<b>Water consumption: Gallons/hr:</b>	79.25 gal/hr (300 liters)
<b>Water consumption/rack:</b>	0.4 gal/rack (1.5 l/rack)
<b>Wash Temperature:</b>	160 – 172 °F (71-78 °C)
<b>Wash tank size:</b>	26 gal (100 liters)
<b>Wash pump power:</b>	2 hp (1.5 kW)
<b>Rinse Temperature:</b>	180 – 194 °F (82-90 °C)
<b>Rinse pump power:</b>	0.4 hp (0.32 kW)
<b>Rinse pump water flow:</b>	1.32 gal/min (5 l/min)
<b>Initial fill water requirements:</b>	26 gal (100 liters)

## Exhaust Requirements

Unit supplied as standard with extended vent hoods (can be removed during installation if not required).

Exhaust extraction not more than 177 CFM (300 m<sup>3</sup>/h)

Refer to installation diagram for minimum exhaust hood installation height .

## Key Information

<b>Productivity racks per hour (max speed):</b>	200 racks / 3600 dishes (average 18 dishes per rack)
<b>Productivity racks per hour (min speed):</b>	130 racks / 2340 dishes (average 18 dishes per rack)
<b>Table to Table connection:</b>	44" (1118 mm)
<b>Number of Tanks:</b>	1
<b>Height with door open:</b>	83-7/16" (2119 mm)
<b>Charging hole size (width):</b>	20-7/8" (530 mm)
<b>Charging hole size (height):</b>	19-3/4" (501 mm)
<b>Net weight:</b>	1012 lb (459 kg)
<b>Shipping weight:</b>	1210 lb (549 kg)
<b>Shipping width:</b>	74-7/16" (1890 mm)
<b>Shipping depth:</b>	40-15/16" (1040 mm)
<b>Shipping height:</b>	81-1/8" (2060 mm)
<b>Shipping volume:</b>	143 cu.ft (4.05 m <sup>3</sup> )
<b>Noise level:</b>	<70 dBA

Unit predisposed to accept external detergent dispensers, detergent probes and rinse aid dispensers.



# Electrolux

## Warewashing 44" Single Tank Conveyor Dishwasher without built in hot water booster WT44

### Front View

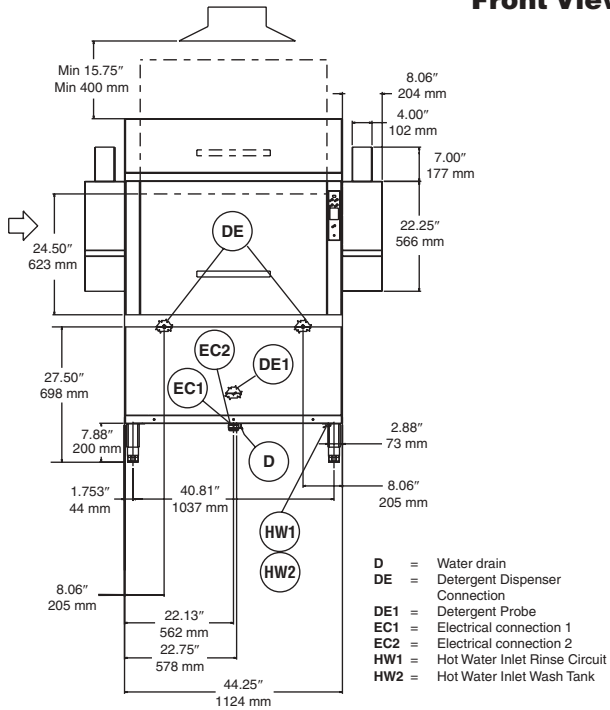

### Top View

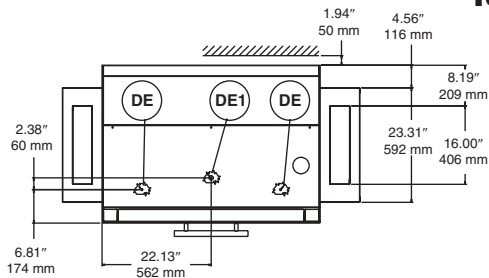

### Side View

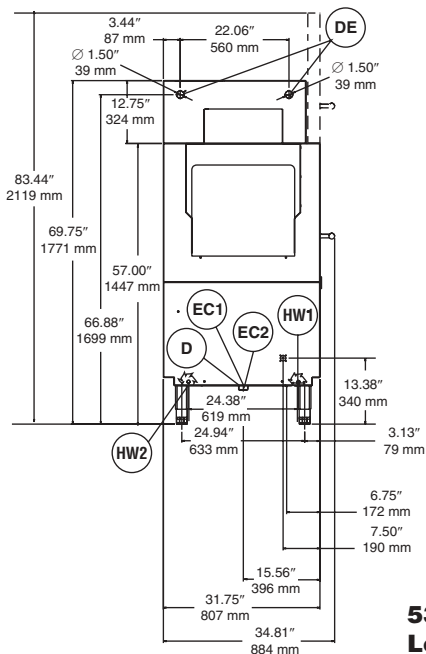

### Front View

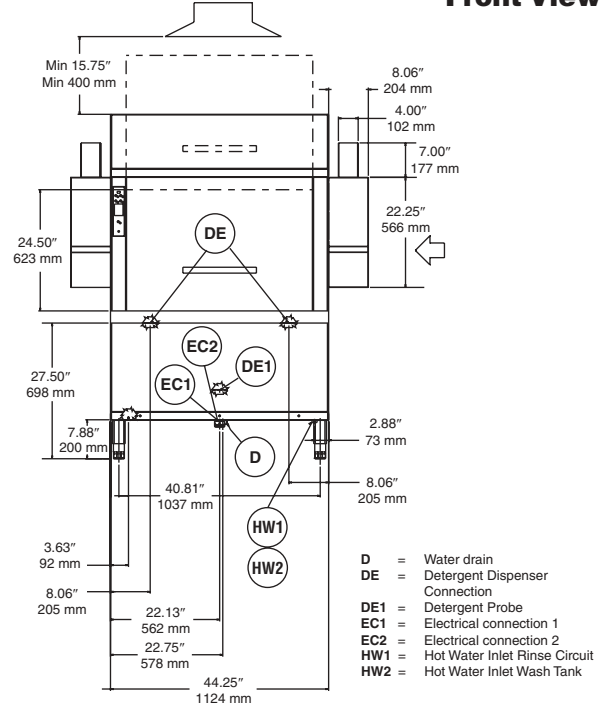

### Top View

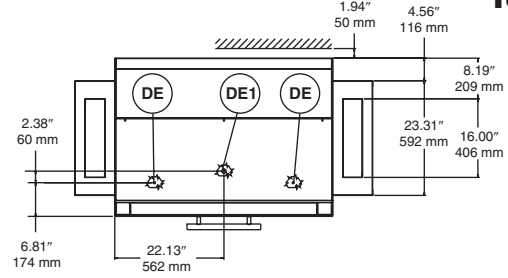

### Side View

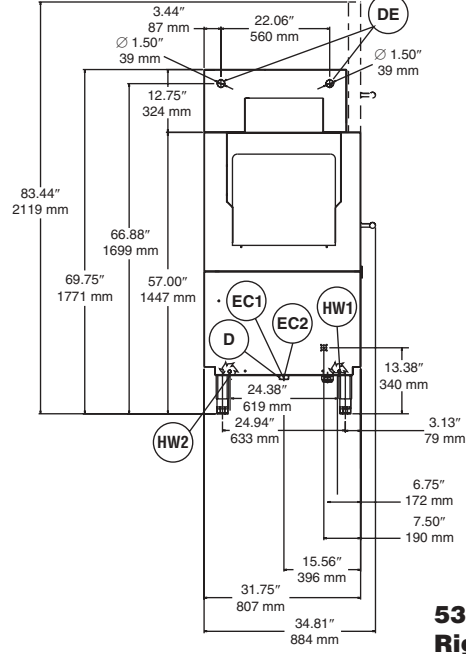



# Electrolux

## Warewashing 44" Single Tank Conveyor Dishwasher without built in hot water booster WT44

### Recommended Table Connection and Fabrication

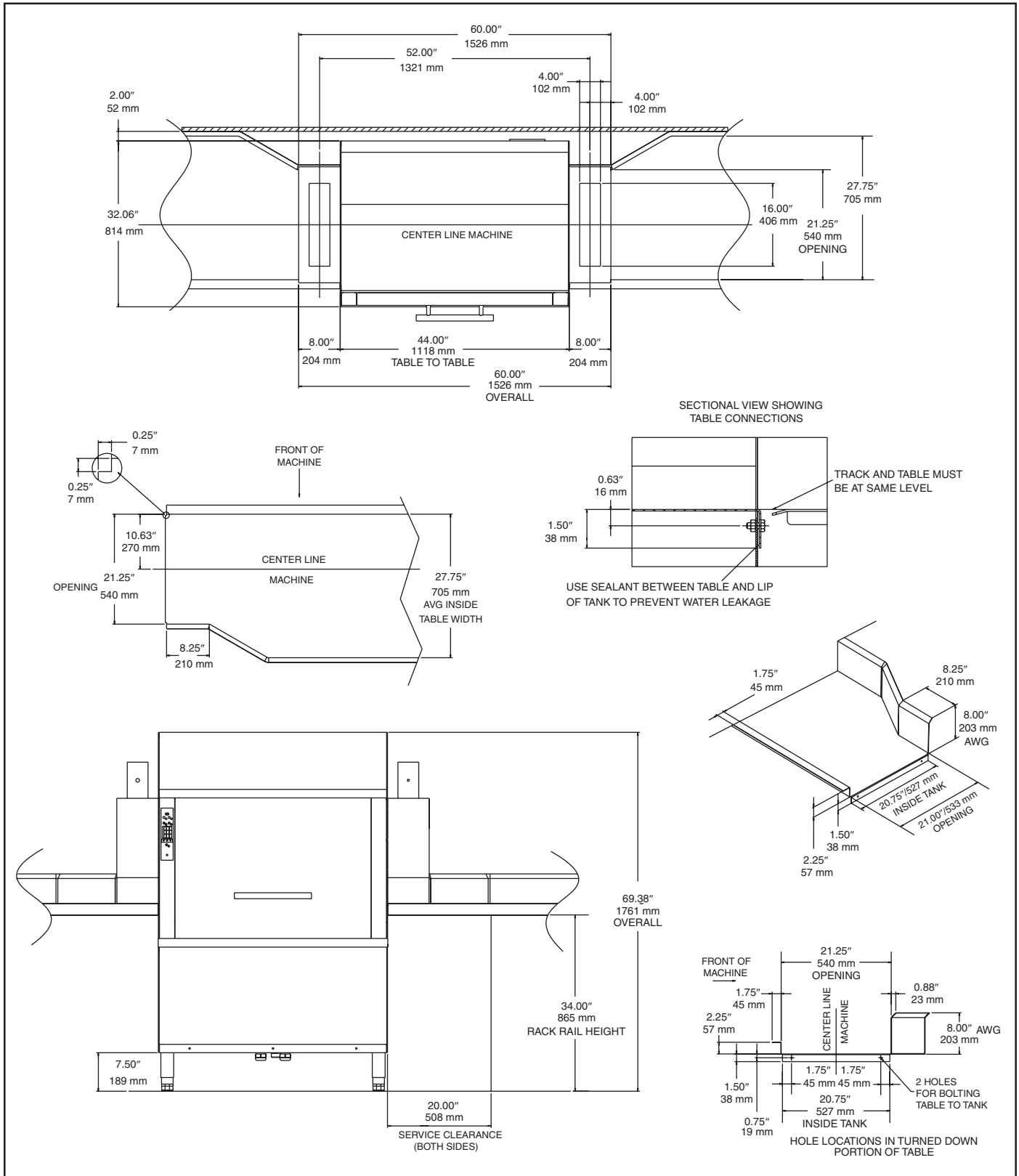

The company reserves the right to make modifications to the products without prior notice. All information correct at time of printing.

Warewashing  
44" Single Tank Conveyor Dishwasher  
without built in hot water booster WT44