



**Warewashing**  
**44" Single Tank Conveyor Dishwasher**  
**with built in hot water booster WT44**

ITEM # \_\_\_\_\_  
 MODEL # \_\_\_\_\_  
 PROJECT NAME # \_\_\_\_\_  
 SIS # \_\_\_\_\_  
 AIA # \_\_\_\_\_



**Warewashing**  
**44" Single Tank Conveyor Dishwasher**  
**with built in hot water booster WT44**

- 534070 (WT44BL208) 44" Conveyor Dishwasher with Built in Booster. Left to Right - 208V
- 534071 (WT44BR208) 44" Conveyor Dishwasher with Built in Booster. Right to Left - 208V
- 534072 (WT44BL240) 44" Conveyor Dishwasher with Built in Booster. Left to Right - 240V
- 534073 (WT44BR240) 44" Conveyor Dishwasher with Built in Booster. Right to Left - 240V

**Short Form Specification**

Item No. \_\_\_\_\_

Unit to be Electrolux WT44 Hot Water Sanitizing 44" single tank conveyor dishwasher with built in hot water booster. Electrical characteristics to be \_\_\_\_ 208 V or \_\_\_\_ 240 V three phase operation. Unit to operate from \_\_\_\_ left to right or \_\_\_\_ right to left. Unit to feature atmospheric built in booster system with built in rinse booster pump thus guaranteeing rinse pressure during rinse cycle. Hot water booster temperature rise can be selected during installation from three options, 40 °F rise (140 °F incoming water temperature), 70 °F rise (110 °F incoming water temperature) or 100 °F rise (80 °F incoming water temperature). Unit to have two conveyor speeds which can be selected from the control panel by the operator, 130 racks/hour or 200 racks/hour. Maximum water consumption at 200 racks/hour of only 79 gal/hour (0.4 gal/rack). Unit to feature large heat and noise insulated front counter balanced door for easy access of internal components. Powerful 2 hp wash pump and specially designed wash spray arms to guarantee cleaning. Unit to feature as standard end of day self cleaning cycle. Drain of water from the machine can be done through the control panel. Large deep drawn 26 gal wash tank.

Covered by Electrolux Platinum Star™ Service Program two-year parts and one-year labor warranty, installation start-up and performance check-up after one year from installation.



**Main features**

- Built in hot water booster (top mounted).
- Water booster temperature rise can be set on site during the installation of the machine. 40 °F rise (140 °F incoming water temperature), 70 °F rise (110 °F incoming water temperature) or 100 °F rise (80 °F incoming water temperature).
- Atmospheric booster system with air break.
- Built in rinse Hot Water booster pump guarantees constant rinse pressure.
- Speed of conveyor can be set through the control panel by the operator. 130 racks/hr or 200 racks/hr.
- Large counter balanced inspection doors allow unrestricted all round access to the wash and rinse area. Door is insulated with injected foam. This adds strength as well as reduces noise and heat loss.
- Large filters sloping towards the front to the smaller pressed filter box for quick removal. Filters feature holes smaller than the concave ant-block wash nozzles so large food cannot enter and block the wash system.
- Adjustable feet for full access underneath the machine for cleaning.
- Push button self cleaning cycle of the wash and rinse zones for ease of "end of day" cleaning.
- Wash chamber without internal pipes and therefore no hidden dirt traps.
- Self draining wash pumps provide maximum hygiene with no smells and all wash and rinse zones drain automatically at the push of a button.
- Powerful 2 hp wash pump.
- Heavy duty Stainless steel wash pump (impeller and housing).
- Deep drawn pressed 26 gal wash tank with fully rounded corners, sloped towards the drain to prevent dirt build up provides fast drainage in only a few minutes. Pressed wash tank with no welded points offer a guaranteed water tight solution.
- Dishwasher structure is held together with a solid 2" x 2" Stainless steel tube sub-frame to provide long term sturdiness.
- All main components made in heavy duty anti-corrosive 304 type Stainless steel: tanks, panels, wash & rinse arms and caps, doors, front, handle, rear and side-panels and rack transportation system.
- Wash and rinse arms can be easily removed for cleaning.
- IPX5 (NEMA4) water protection ensures no damage from cleaning.
- Autostart/stop ensures that the machine runs only when a rack is passing through it. This reduces both water and energy consumption.
- Internal curtains made of silastic material and are not affected by detergent or heat.
- Electronic control panel features large display for reading of wash and rinse temperatures.
- Low water consumption. At 200 racks per hour, the machine uses only 79 gal/hr (0.4 gal/rack).
- Machine predisposed for external detergent and rinse aid connections.

**Included Accessories**

- Vent cowls (left and right side)
- One open sided dishwasher rack for trays
- Rack for cups.
- Rack for dinner plates.

**Optional Accessories**

- Ventilation activation kit

Approval: \_\_\_\_\_



## Warewashing 44" Single Tank Conveyor Dishwasher with built in hot water booster WT44

### Electric

<b>Supply voltage:</b>	534070	208 V/3p/60Hz
	534071	208 V/3p/60Hz
	534072	240 V/3p/60Hz
	534073	240 V/3p/60Hz

Dishwasher has three selectable hot water booster configurations according to inlet water supply temperature.

Dishwasher requires two separate electrical service connections. Connection 1 for Hot Water Booster; Connection 2 for running of the machine (wash pump, tank heat, conveyor drive motor, rinse booster pump, electronic control). Refer to the information below for Amp requirements.

### Booster 40 °F rise Electrical Characteristics

#### Hot Water Booster Amp Load Connection 1:

208 V/3p/60Hz	33.35A (12 kW)
240 V/3p/60Hz	28.9A (12 kW)

#### Wash Pump, Tank heat Amp Load Connection 2:

208 V/3p/60Hz	61.7A (21 kW)
240 V/3p/60Hz	55A (21 kW)

#### Total Amp Load: 208 V/3p/60Hz

95A (33 kW)	
240 V/3p/60Hz	83.9A (33 kW)

### Booster 70 °F rise Electrical Characteristics

#### Hot Water Booster Amp Load Connection 1:

208 V/3p/60Hz	50A (18 kW)
240 V/3p/60Hz	43.3A (18 kW)

#### Wash Pump, Tank heat Amp Load Connection 2:

208 V/3p/60Hz	61.7A (21 kW)
240 V/3p/60Hz	55A (21 kW)

#### Total Amp Load: 208 V/3p/60Hz

111.6A (39 kW)	
240 V/3p/60Hz	98.3A (39 kW)

### Booster 100 °F rise Electrical Characteristics

#### Hot Water Booster Amp Load Connection 1:

208 V/3p/60Hz	66.6A (24 kW)
240 V/3p/60Hz	57.7A (24 kW)

#### Wash Pump, Tank heat Amp Load Connection 2:

208 V/3p/60Hz	61.7A (21 kW)
240 V/3p/60Hz	55A (21 kW)

#### Total Amp Load: 208 V/3p/60Hz

128.3A (45 kW)	
240 V/3p/60Hz	112.7A (45 kW)

### Water

<b>Inlet Water supply pressure:</b>	22 – 102 psi (150 – 700 kPa)
<b>Inlet Water supply temperature (booster size can be set on site during installation):</b>	140 °F (60 °C) with booster set as 40 °F rise. 110 °F (44 °C) with booster set as 70 °F rise. 80 °F (27 °C) with booster set as 100 °F rise.

<b>Inlet Water supply hardness:</b>	4-8 gpg (7-14 °fH) max
<b>Incoming water line size:</b>	G 3/4"

**NOTE:** Two Hot Water Inlets on machine can be fed by one incoming Hot Water line.

<b>Drain line size:</b>	G 1-1/2"
<b>Water consumption: Gallons/hr:</b>	79.25 gal/hr (300 liters)
<b>Water consumption/rack:</b>	0.4 gal/rack (1.5 l/rack)
<b>Wash Temperature:</b>	160 – 172 °F (71-78 °C)
<b>Wash tank size:</b>	26 gal (100 liters)
<b>Wash pump power:</b>	2 hp (1.5 kW)
<b>Wash pump water flow:</b>	118.9 gal/min (450 l/min)
<b>Rinse Temperature:</b>	180 – 194 °F (82-90 °C)
<b>Rinse pump power:</b>	0.4 hp (0.32 kW)
<b>Rinse pump water flow:</b>	1.32 gal/min (5 l/min)
<b>Hot water booster capacity:</b>	6.2 gal (24 liters)
<b>Initial fill water requirements:</b>	32.2 gal (124 liters)

### Exhaust Requirements

Unit supplied as standard with extended vent hoods (can be removed during installation if not required). Exhaust extraction not more than 177 CFM (300 m<sup>3</sup>/h) Refer to installation diagram for minimum exhaust hood installation height .

### Key Information

<b>Productivity racks per hour (max speed):</b>	200 racks / 3600 dishes (average 18 dishes per rack)
<b>Productivity racks per hour (min speed):</b>	130 racks / 2340 dishes (average 18 dishes per rack)
<b>Table to Table connection:</b>	44" (1118 mm)
<b>Number of Tanks:</b>	1
<b>Height with door open:</b>	83-7/16" (2119 mm)
<b>Charging hole size (width):</b>	20-7/8" (530 mm)
<b>Charging hole size (height):</b>	19-3/4" (501 mm)
<b>Net weight:</b>	1012 lb (459 kg)
<b>Shipping weight:</b>	1210 lb (549 kg)
<b>Shipping width:</b>	74-7/16" (1890 mm)
<b>Shipping depth:</b>	40-15/16" (1040 mm)
<b>Shipping height:</b>	81-1/8" (2060 mm)
<b>Shipping volume:</b>	143 cu.ft (4.05 m <sup>3</sup> )
<b>Noise level:</b>	<70 dBA

Unit predisposed to accept external detergent dispensers, detergent probes and rinse aid dispensers.

**Front View**

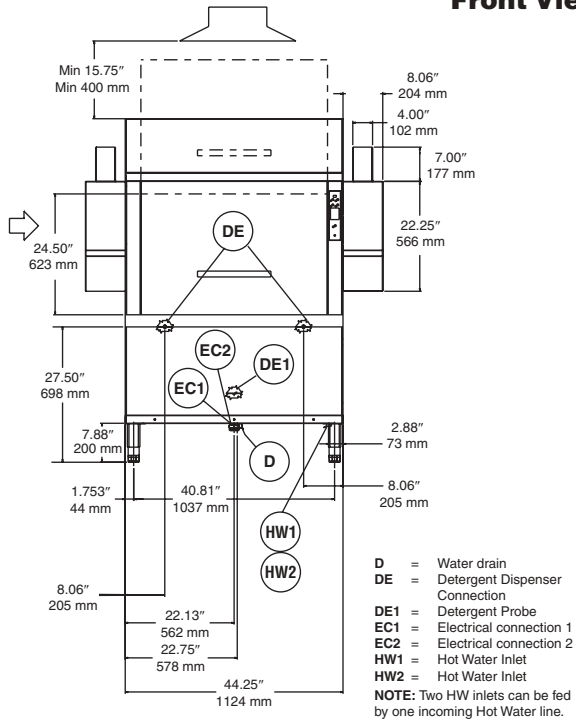

**Top View**

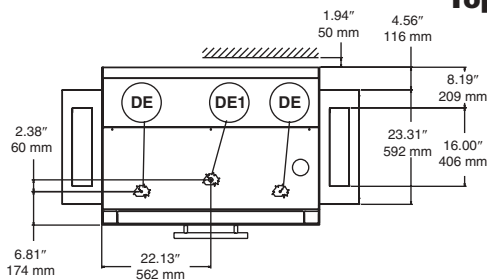

**Side View**

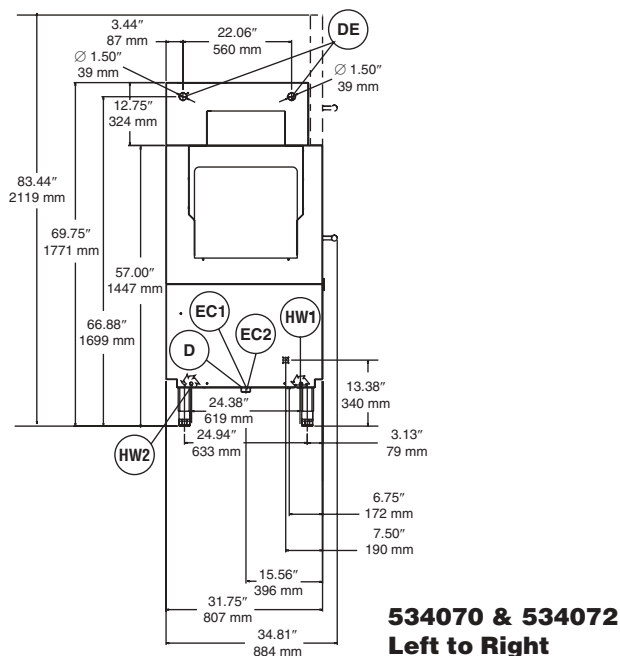

**Front View**

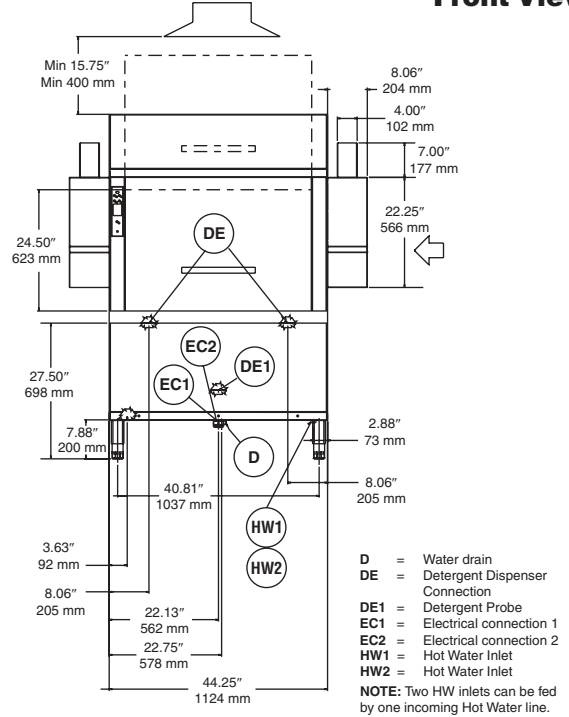

**Top View**

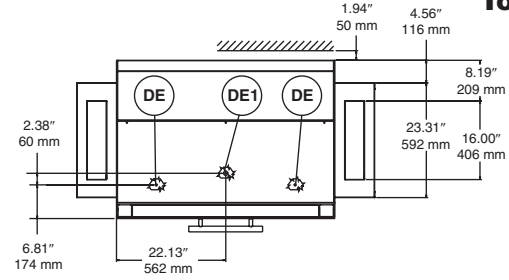

**Side View**

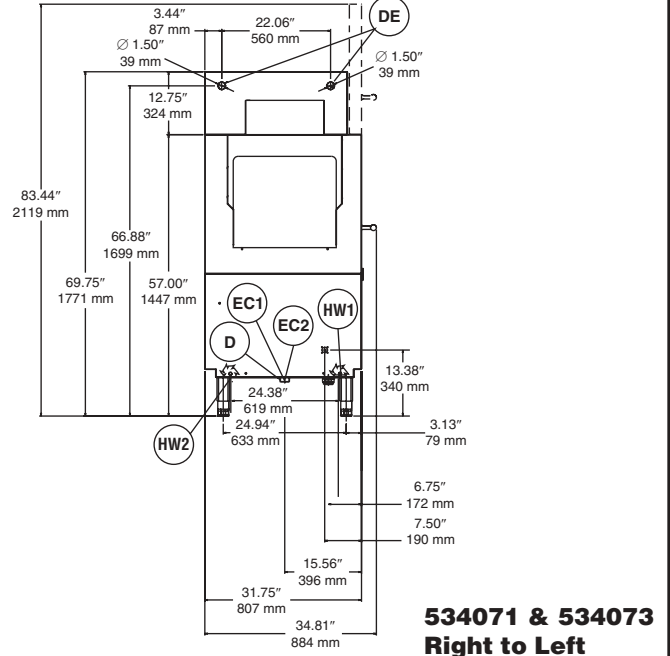

### Recommended Table Connection and Fabrication

