



**air-o-steam®  
Gas Combi Oven 201**

ITEM # \_\_\_\_\_  
 MODEL # \_\_\_\_\_  
 PROJECT NAME # \_\_\_\_\_  
 SIS # \_\_\_\_\_  
 AIA # \_\_\_\_\_



**air-o-steam® Gas Combi Oven 201**

267554 (AOS201GAP1) Gas Combi Oven 201  
 120 V/1p/60Hz - 7.3A

**Short Form Specification**

Item No. \_\_\_\_\_

Unit to be Electrolux air-o-steam® Combi Oven AOS201G. The air-o-steam® features three cooking modes – Steam (77 °F-266 °F), Hot convected air (77 °F-572 °F) and Combi-mode (77 °F-482 °F). Each cooking mode operates under Lambda-sensor driven air-o-clima™: automatic and constant real humidity control. 6 point multi sensor for core temperature controlled cooking cycles. Pre-programmed low temperature cooking cycle (LTC) and programmable memory (up to 100, 7-step programs available), 20 factory pre-set cooking programs included. Large LED display for both set and actual values of humidity and temperature in cooking chamber during cooking. All 304 Stainless-steel construction, seamless hygienic cooking chamber with all rounded corners. Double thermo-glazed door with open frame construction for cool outside door panel. Halogen cooking chamber lighting. IPX-5 (NEMA 4) spray water protection certification.

Air-o-clean, automatic and built-in self-cleaning system.  
 EKIS, pc-controlled HACCP monitoring software package available at additional cost.

Half day chef training included.  
 Covered by Electrolux Platinum Star™ Service Program two-year parts and one-year labor warranty, installation start-up and performance check-up after one year from installation.



Approval: \_\_\_\_\_

**Main features**

- Dry, hot convection cycle (77 °F to 572 °F): ideal for low humidity baking.
- Low temperature Steam cycle (77 °F to 211 °F): ideal for sous-vide (vacuum packed) re-thermalization and delicate cooking.
- Steam cycle (212 °F): seafood and vegetables.
- High temperature steam (213 ° F to 266 ° F).
- Combination cycle (77 °F to 482 °F): combining convected heat and steam to obtain humidity controlled cooking environment, accelerating the cooking process and reducing weight loss.
- Pre-programmed re-thermalization cycles for banqueting applications.
- **Air-o-clima™**: Lambda sensor controlled automatic humidity adjustment of cooking environment.
- 6-point multi sensor core temperature probe.
- Pre-programmed Low Temperature Cooking cycle (LTC): minimizes weight loss, maximizes food quality for large pieces of meat.
- Cook&Hold cycle.
- Variable fan speed. Radial fan.
- Reduced power cycle.
- 20 pre-set cooking programs in memory for most popular cooking items.
- 100 program locations in on-board memory, up to 7 cooking steps each.
- **Air-o-clean**: built-in and automatic self-cleaning system.
- Electrolux Platinum Star™ service package included:
  - 2-year parts, 1-year labor warranty.
  - Start-up install check.
  - Equipment check-up after 12 month from installation.
  - Half day Chef training session.

**Construction**

- High efficiency and low emissions burners.
- IPX 5 splash water protection certification for easy cleaning.
- All 304 Stainless steel construction.
- Seamless hygienic cooking chamber with all rounded corners for easy cleaning.
- Double thermo-glazed door with open frame construction, for cool outside door panel.
- Swing hinged easy-release inner glass on door for easy cleaning.
- Swing hinged front panel for easy service access to main components.

**Included Accessories**

- 1 of Rack Trolley (20 racks) PNC 922007
- 10 of 304 Stainless steel grids PNC 922062

**Optional Accessories**

- Increased pitch rack Trolley (16 grids) PNC 922010
- 54 plate trolley PNC 922016
- 45 plate trolley PNC 922072
- Thermal blanket for banqueting trolley PNC 922014
- Pair of chicken racks (8 chickens per rack) PNC 922036
- Non-stick universal pans PNC 922090-2
- Combi oven grill PNC 922093
- Fat Filters PNC 922179
- Frying griddle PNC 922215
- Pair of frying baskets PNC 922239
- Heat shield for 201 PNC 922243
- External Hand Shower PNC 923006



**Front View**

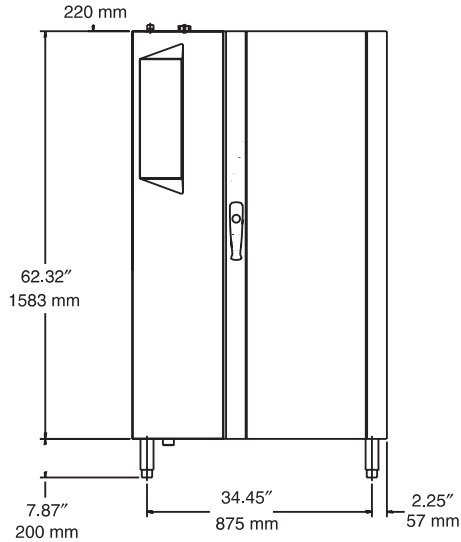

**Top View**

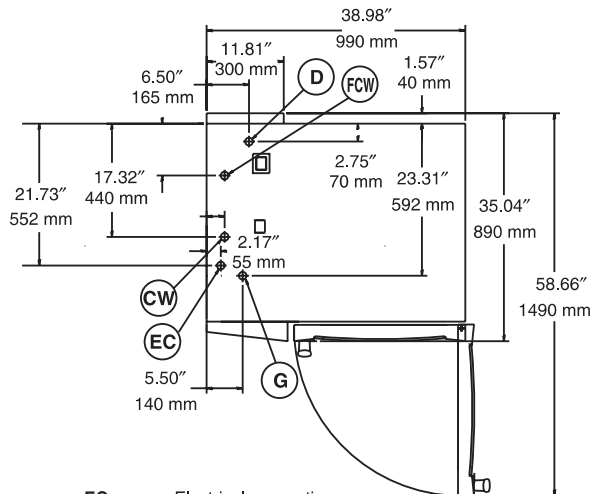

- EC = Electrical connection
- G = Gas connection
- D = Water drain
- CW = Cold Water inlet
- FCW = Filtered Cold Water inlet

**Side View**

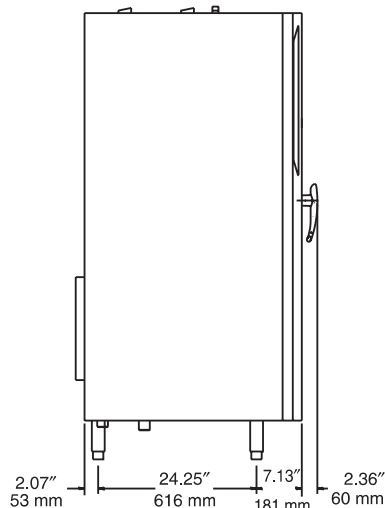

### Electric

**Supply voltage:**  
267554 (AOS201GAP1) 120 V/1p/60Hz - 7.3A  
**Circuit breaker required:**

### Gas (Natural or LPG)

**Gas (Natural or LPG)**  
**ISO 7/1 Gas connection diameter:** 1" MNPT  
Gas regulator recommended. Supplied by others.

#### Max rated thermal load:

##### Natural Gas

**Pressure:** 7" w.c. (17.4 mbar)  
**Steam generator:** BTU 116,000 (34 kW)  
**Heating elements:** BTU 170,600 (50 kW)  
**Total:** BTU 286,600 (84 kW)

##### LPG

**Pressure:** 11" w.c. (27.4 mbar)  
**Steam generator:** BTU 102,400 (30 kW)  
**Heating elements:** BTU 153,600 (45 kW)  
**Total:** BTU 256,000 (75 kW)

### Water

#### Water inlet "CW" - 3/4" connection:

Unfiltered drinking water

#### Water inlet "FCW" - 3/4" connection:

**Total hardness:** 5-50 ppm  
**Pressure:** 22-36 psi (150-250 kPa)

#### Drain "D":

1-1/4" connection

*Electrolux recommends the use of treated water, based on testing of specific water conditions.*

*Please refer to user manual for detailed water quality information.*

### Installation

**Clearance:** 2" (5 cm) rear and right hand sides.

**Suggested clearance for service access:** 20" (50 cm) left hand side.

### Capacity

**Steam pans:** 20 - 12" x 20"  
**Half size sheet pans:** 20 - 13" x 18"  
**GN:** 20 - 1/1 containers  
**Max load capacity:** 220 lbs. (100 kg)

### Key Information

**Net weight:** 551 lbs. (250 kg)  
**Shipping weight:** 640 lbs. (290 kg)  
**Shipping width:** 41-3/4" (1060 mm)  
**Shipping height:** 81-1/8" (2060 mm)  
**Shipping depth:** 39" (990 mm)  
**Shipping Volume:** 76.5 cu. ft. (2.16 m<sup>3</sup>)

air-o-steam®  
Gas Combi Oven 201

The company reserves the right to make modifications to the products without prior notice. All information correct at time of printing.