

## air-o-steam® Electric Combi Oven 201

ITEM # \_\_\_\_\_

MODEL # \_\_\_\_\_

PROJECT NAME # \_\_\_\_\_

SIS # \_\_\_\_\_

AIA # \_\_\_\_\_



### air-o-steam® Electric Combi Oven 201

- 267084 (AOS201EAM1)** Electric Combi Oven 201 –  
208 V/3p/60Hz - 96A
- 267094 (AOS201EAB1)** Electric Combi Oven 201 –  
240 V/3p/60Hz – 83A

### Short Form Specification

Item No. \_\_\_\_\_

Unit to be Electrolux air-o-steam® Combi Oven AOS201E. The air-o-steam® features three cooking modes – Steam (77 °F-266 °F), Hot convected air (77 °F-572 °F) and Combi-mode (77 °F-482 °F). Each cooking mode operates under Lambda-sensor driven air-o-clima™: automatic and constant real humidity control. 6 point multi sensor for core temperature controlled cooking cycles. Pre-programmed low temperature cooking cycle (LTC) and programmable memory (up to 100, 7-step programs available), 20 factory pre-set cooking programs included. Large LED display for both set and actual values of humidity and temperature in cooking chamber during cooking. All 304 Stainless-steel construction, seamless hygienic cooking chamber with all rounded corners. Double thermo-glazed door with open frame construction for cool outside door panel. Halogen cooking chamber lighting. IPX-5 (NEMA 4) spray water protection certification.

Air-o-clean, automatic and built-in self-cleaning system.

EKIS, pc-controlled HACCP monitoring software package available at additional cost.

Half day chef training included.

Covered by Electrolux Platinum Star™ Service Program two-year parts and one-year labor warranty, installation start-up and performance check-up after one year from installation.



Approval: \_\_\_\_\_

### Main features

- Dry, hot convection cycle (77 °F to 572 °F): ideal for low humidity baking.
- Low temperature Steam cycle (77 °F to 211 °F): ideal for sous-vide (vacuum packed) re-thermalization and delicate cooking.
- Steam cycle (212 °F): seafood and vegetables.
- High temperature steam (213 °F to 266 °F).
- Combination cycle (77 °F to 482 °F): combining convected heat and steam to obtain humidity controlled cooking environment, accelerating the cooking process and reducing weight loss.
- Pre-programmed re-thermalization cycles for banqueting applications.
- **Air-o-clima™**: Lambda sensor controlled automatic humidity adjustment of cooking environment.
- 6-point multi sensor core temperature probe.
- Pre-programmed Low Temperature Cooking cycle (LTC): minimizes weight loss, maximizes food quality for large pieces of meat.
- Cook&Hold cycle.
- Variable fan speed. Radial fan.
- Reduced power cycle.
- 20 pre-set cooking programs in memory for most popular cooking items.
- 100 program locations in on-board memory, up to 7 cooking steps each.
- **Air-o-clean**: built-in and automatic self-cleaning system.
- Electrolux Platinum Star™ service package included:
  - 2-year parts, 1-year labor warranty.
  - Start-up install check.
  - Equipment check-up after 12 month from installation.
  - Half day Chef training session.

### Construction

- IPX 5 splash water protection certification for easy cleaning.
- All 304 Stainless steel construction.
- Seamless hygienic cooking chamber with all rounded corners for easy cleaning.
- Double thermo-glazed door with open frame construction, for cool outside door panel.
- Swing hinged easy-release inner glass on door for easy cleaning.
- Swing hinged front panel for easy service access to main components.

### Included Accessories

- 1 of Rack Trolley (20 racks) PNC 922007
- 10 of 304 Stainless steel grids PNC 922062

### Optional Accessories

- Increased pitch rack Trolley (16 grids) PNC 922010
- 54 plate trolley PNC 922016
- 45 plate trolley PNC 922072
- Thermal blanket for banqueting trolley PNC 922014
- Pair of chicken racks (8 chickens per rack) PNC 922036
- Non-stick universal pans PNC 922090-2
- Combi oven grill PNC 922093
- Fat Filters PNC 922179
- Stacking kit 61 on top of 61 or 101 electric PNC 922217
- Heat shield for 201 PNC 922243
- Heat shield for 101 PNC 922251
- External Hand Shower PNC 923006

**Front View**

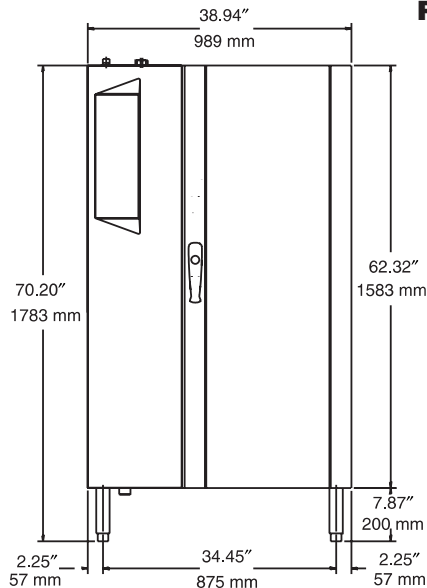

**Top View**

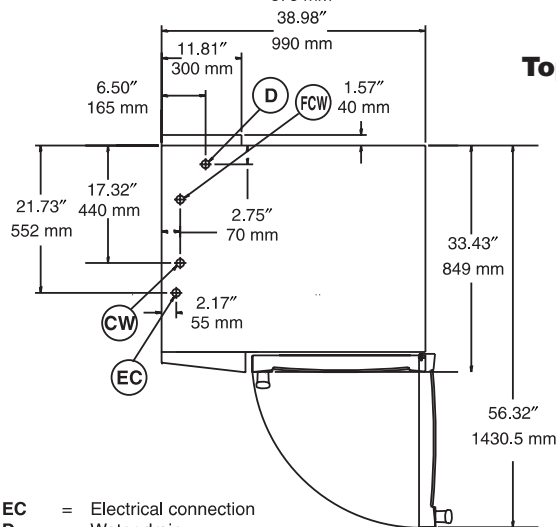

- EC = Electrical connection
- D = Water drain
- CW = Cold Water inlet
- FCW = Filtered Cold Water inlet

**Side View**

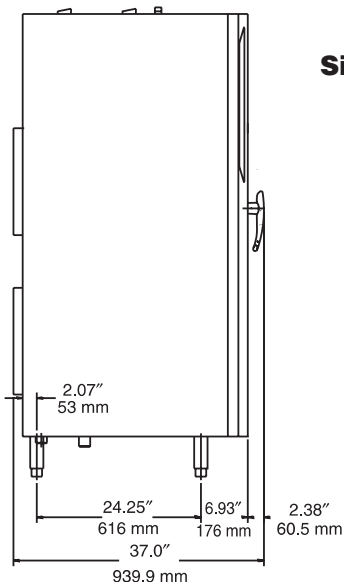

## Electric

**Supply voltage:**

267084 (AOS201EAM1) 208 V/3p/60Hz - 96A

267094 (AOS201EAB1) 240 V/3p/60Hz - 83A

**Connected load:**

34.5 kW

**Circuit breaker required**

## Water

**Water inlet "CW" – 3/4" connection:**

Unfiltered drinking water

**Water inlet "FCW" - 3/4" connection:**

**Total hardness:** 5-50 ppm

**Pressure:** 22-36 psi (150-250 kPa)

**Drain "D"**

1-1/4" connection

*Electrolux recommends the use of treated water, based on testing of specific water conditions.*

*Please refer to user manual for detailed water quality information.*

## Installation

**Clearance:**

2" (5 cm) rear and right hand sides.

**Suggested clearance for service access:**

20" (50 cm) left hand side.

## Capacity

**Steam pans:**

20 – 12" x 20"

**Half size sheet pans:**

20 – 13" x 18"

**GN:**

20 – 1/1 containers

**Max load capacity:**

220 lbs. (100 kg)

## Key Information

**Net weight:**

534 lbs. (242 kg)

**Shipping weight:**

640 lbs. (290 kg)

**Shipping width:**

41-3/4" (1060 mm)

**Shipping height:**

81-1/8" (2060 mm)

**Shipping depth:**

39" (990 mm)

**Shipping Volume:**

76.5 cu. ft. (2.16 m<sup>3</sup>)