

air-o-speed® High Speed Combi Oven 101

ITEM # _____
 MODEL # _____
 PROJECT NAME # _____
 SIS # _____
 AIA # _____



air-o-speed®
High Speed Combi Oven 101
 260573 (AOW101EABU) High Speed Combi Oven 101
 208 V/3p/60Hz - 64A

* Base not included

Short Form Specification

Item No. _____

Unit to be Electrolux air-o-speed® High Speed Combi Oven AOW101E. The air-o-speed® features the three cooking modes – Steam (77 °F-266 °F), Hot convected air (77 °F-572 °F), Combi-mode (77 °F-482 °F) of a traditional Combi oven and the added benefit of patent pending Multiwave technology, reducing cooking times by up to 50%. Multiwave technology allows for use of standard s/s or aluminum cooking trays and pans (up to 10 steam table sized pans 12" x20" x 2-1/2"). Each cooking mode operates under Lambda-sensor driven air-o-clima™: automatic and constant real humidity control. Patented Multiwave can be used by itself and in conjunction with any of the other cooking modes. All cooking modes can be used independently or in sequence of up to 6 steps. To feature large LCD display for easy programming and cooking programs access. To feature pictogram driven automatic cooking mode. 6 point multi sensor for core temperature controlled cooking cycles. Pre-programmed low temperature cooking cycle (LTC) and programmable memory (up to 100, 6-step programs available), 20 factory pre-set cooking programs included. All 304 Stainless-steel construction, seamless hygienic cooking chamber with all rounded corners. Triple thermo-glazed door. Halogen cooking chamber lighting. IPX5 (Nema 4) splash water protection certification. Retractable spray hose included as standard.

Air-o-clean™, automatic and built-in self-cleaning system.
 EKIS, pc-controlled HACCP monitoring software package available at additional cost.
 Half day chef training included.
 Covered by Electrolux Platinum Star™ Service Program two-year parts and one-year labor warranty, installation start-up and performance check-up after one year from installation.



Approval: _____

Main features

- Patent pending Multiwave technology that can be combined with all traditional Combi-cooking modes to accelerate the cooking process, maintaining the maximum level of quality in the result.
- **Air-o-speed** 3-mode interface: "automatic" (PATENT PENDING) for new operators, "manual" for programs customizing, "programs" for pre-set recipes.
- Dry, hot convection cycle (77 °F to 572 °F): ideal for low humidity baking.
- Saturated low temperature Steam cycle (77 °F to 211 °F): ideal for sous-vide (vacuum packed) re-thermalization and delicate cooking.
- Steam cycle (212 °F): seafood and vegetables.
- High temperature steam (213 °F to 266 °F).
- Combination cycle (77 °F to 482 °F): combining convected heat and steam to obtain humidity controlled cooking environment, accelerating the cooking process and reducing weight loss.
- Up to 50% reduction of cooking times.
- Frozen to ready cooking application.
- Will work with all standard metal cookware (steam table sized pans)
- **Air-o-clima™**: Lambda sensor controlled automatic humidity adjustment of cooking environment (PATENT).
- 6-point multi sensor core temperature probe.
- Pre-programmed Low Temperature Cooking cycle (LTC): minimizes weight loss, maximizes food quality for large pieces of meat (PATENT).
- Pre-programmed re-thermalization cycles for banqueting applications.
- Cook&Hold cycle. Hold function: provides an impulse ventilation ideal for holding and light pastry.
- Variable fan speed. Radial fan.
- Reduced power cycle.
- Over 300 cooking programs in memory for most popular cooking items.
- 100 program locations in on-board memory, up to 7 cooking steps each.
- Ready for EKIS software (pc-based HACCP monitoring package).
- Ready for HACCP monitoring via printer.
- **Air-o-clean™**: built-in and automatic self-cleaning system.
- Electrolux Platinum service package included:
 - 2-year parts, 1-year labor warranty.
 - Start-up install check.
 - Equipment check-up after 12 month from installation.
 - Half day Chef training session.

Construction

- IPX 5 (Nema 4) splash water protection certification for easy cleaning.
- All 304 Stainless steel construction.
- Seamless hygienic cooking chamber with all rounded corners for easy cleaning.
- Triple thermo-glazed door.
- Swing hinged easy-release inner glass on door for easy cleaning.
- Swing hinged front panel for easy service access to main components.
- Integrated spray hose included.

Included Accessories

- 1 of Rack Cassette (10 racks) PNC 922006
- 10 of 304 Stainless steel grids PNC 922062

Optional Accessories

- Open base stand PNC 922083
- Cupboard base stand PNC 922084
- Trolley for Rack Cassette PNC 922004
- Wheels kit for rack cassette PNC 922073
- Roll-in rack support PNC 922047
- Increased pitch rack cassette (8 racks) PNC 922009
- 29 plate rack PNC 922015
- 23 plate rack PNC 922071
- Thermal blanket for banqueting rack PNC 922013
- Pair of chicken racks (8 chickens per rack) PNC 922036
- Non-stick universal pans PNC 922090-2
- Combi oven grill PNC 922093
- 4 castors (2 with brake) PNC 922057
- HACCP printer PNC 880048

Front View

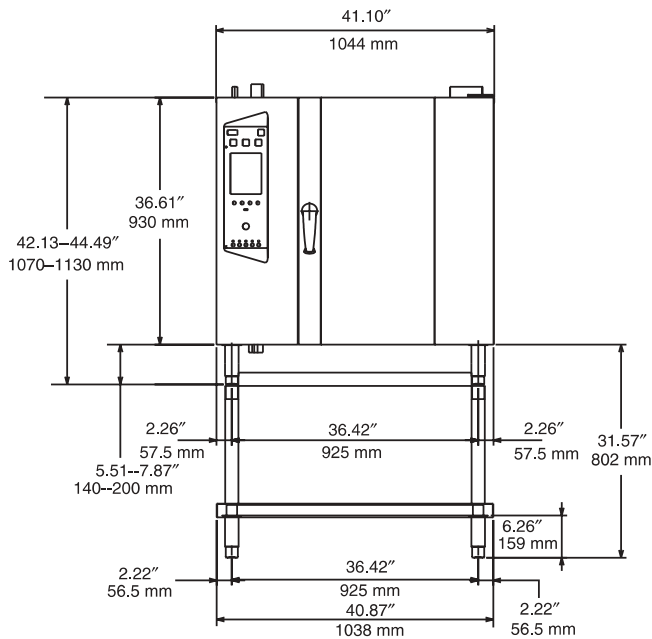

Top View

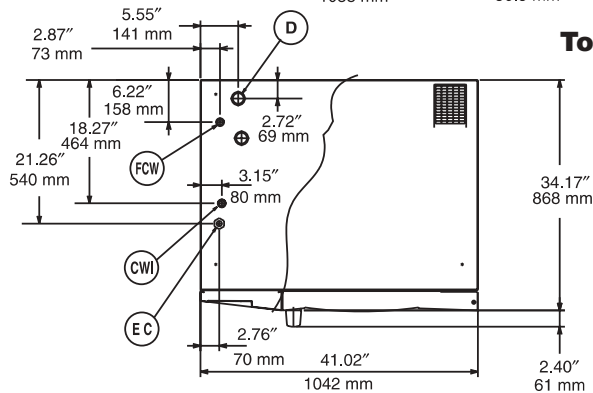

- EC = Electrical connection
- D = Water Drain
- CWI = Cold water inlet
- FCW = Filtered cold water

Side View

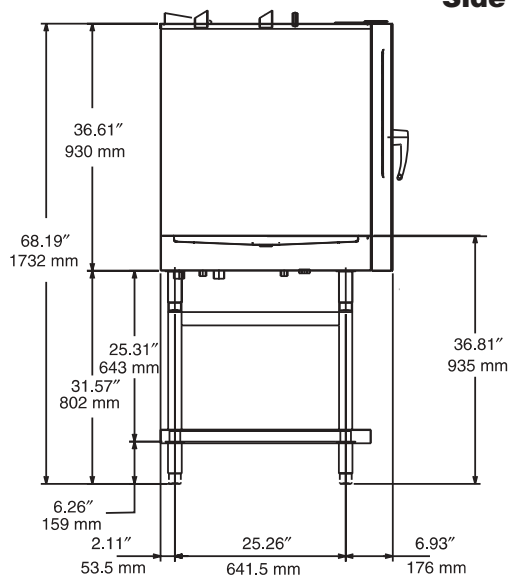

Electric

Supply voltage:

260573 (AOW101EABU) 208 V/3p/60Hz - 64A

Connected load:

23 kW

Circuit breaker required

Water

Water inlet "CW" - 3/4" connection:

Unfiltered drinking water

Water inlet "FCW" - 3/4" connection:

Total hardness: 5-50 ppm

Pressure: 22-36 psi (150-250 kPa)

Drain "D":

1-1/4" connection

Electrolux recommends the use of treated water, based on testing of specific water conditions.

Please refer to user manual for detailed water quality information.

Installation

Clearance:

Clearance: 2" (5 cm) rear and right hand sides.

Suggested clearance for service access:

20" (50 cm) left hand side.

Capacity

Steam pans:

10 - 12" x 20"

Half size sheet pans:

10 - 13" x 18"

GN:

10 - 1/1 containers

Max load capacity:

110 lbs. (50 kg)

Key Information

Net weight:

529 lbs. (240 kg)

Shipping weight:

595 lbs. (270 kg)

Shipping width:

45-1/4" (1150 mm)

Shipping height:

53-15/16" (1370 mm)

Shipping depth:

41-9/16" (1055 mm)

Shipping volume:

58.62 cu. ft. (1.66 m³)