

Electrolux

Free standing Pasta Cooker Single-well Pasta Cooker Electric Rapid System

ITEM # _____

MODEL # _____

PROJECT NAME # _____

SIS # _____

AIA # _____



Free standing Pasta Cooker Single-well Pasta Cooker Electric Rapid System

200374 (NCPE1RU) Rapid System Electric Pasta Cooker
208 V/3p/60z – 36 A

Short Form Specification

Item No. _____

Unit to be Electrolux Rapid System Single Well Electric Pasta Cooker 200374. Features incoming water booster heater. The unit is a free-standing, 10.5 gallon, single well Electric Pasta Cooker. The unit shall feature constant water level refill and starch removal during cooking process. IPX 5 water jet protection (NEMA 4 equivalent). The 10.5 gallon tank is pressed in AISI 316 Stainless steel and features only rounded corners. 5" long, height adjustable legs. The unit to be completely in AISI 304 Stainless steel.

Covered by Electrolux Platinum Star™ Service Program two-year parts and one-year labor warranty, installation start-up and performance check-up after one year from installation.



Approval: _____

Main features

- Rapid system: incoming water booster heater.
- 10.5 Gallon tank.
- 9-position energy regulator.
- 3-position water fill regulator.
- Constant water level refill.
- Automatic starch removal function during cooking: improved water quality over time.
- Automatic low-water level shut-off: no accidental over-heating.
- Electrolux Platinum service package included:
 - 2-year parts, 1-year labor warranty, 5-year compressor warranty.
 - Start-up install check.
 - Equipment check-up after 12 month from installation.

Construction

- Pressed 10.6 gal tank: only rounded corners for improved cleanability.
- AISI 316 Stainless steel tank: maximum corrosion resistance.
- All Stainless steel construction.
- IPX 5 water jet protection (NEMA 4 equivalent).

Included Accessories

- 5" long, height adjustable legs.

Optional Accessories

- Bulk cooking basket.
- 2 of 1/2 size bulk cooking baskets.
- 3 of 1/3 size bulk cooking baskets.
- 3 of round individual-portion baskets
- False bottom for round individual-portion baskets.
- Castors.

 Electrolux

Free standing Pasta Cooker
Single-well Pasta Cooker – Electric Rapid System

Electrolux Professional, Inc.

www.electroluxusa.com/professional

3225 SW 42nd Street, Fort Lauderdale, Florida, 33312 • Telephone Number: 866-449-4200 • Fax Number: 954-327-6789

Front View

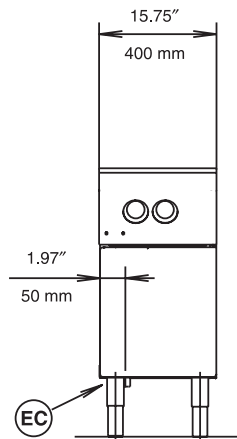

Top View

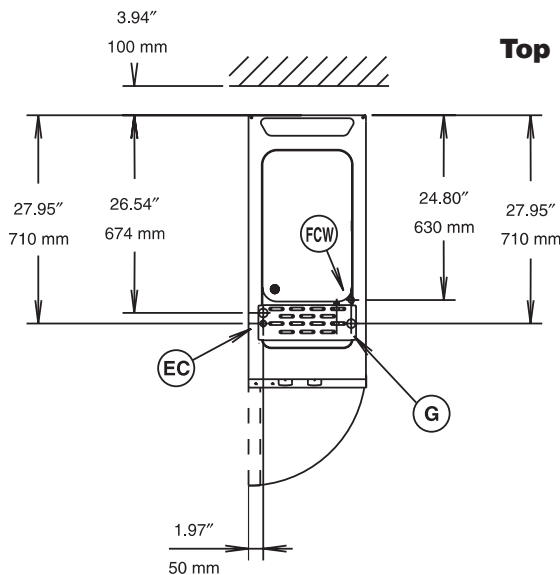

EC = Electrical connection
G = Gas connection
FCW = Filtered Cold Water Inlet

Side View

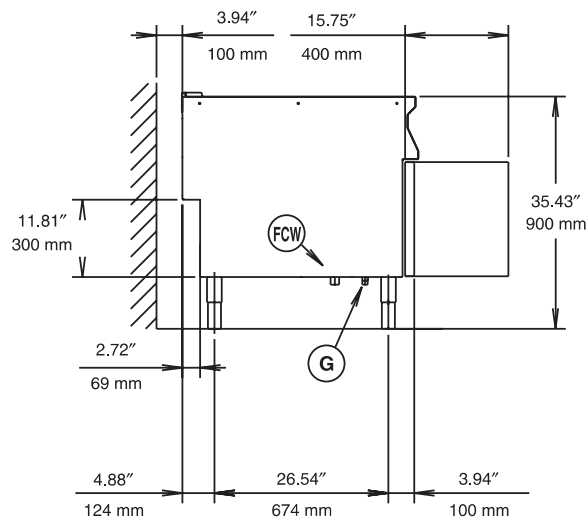

Electric

Supply voltage:

200374 (NCPE1RU) 208 V/3p/60z - 36 A

Connected load:

13 kW

Water

Water inlet "CW" – 1/2" connection:

Total hardness: 5-50 ppm

Drain "D" 1" connection

Electrolux recommends the use of treated water, based on testing of specific water conditions.

Please refer to user manual for detailed water quality information.

Installation

Clearance: 4" (10 cm) from back.

Capacity

Max.: 10.5 gal

Min.: 8.5 gal

Key Information

Net weight: 161 lbs. (73 kg)

Height, inch/mm: 33-7/16" (849 mm)

Width, inch/mm: 15-3/4" (400 mm)

Depth, inch/mm: 35-7/16" (900 mm)

Shipping weight: 201 lbs. (91 kg)

Shipping width: 19" (480 mm)

Shipping height: 44.1" (1120 mm)

Shipping depth: 41" (1040 mm)

Shipping Volume: 19.8 cu. ft. (0.56 m³)

Free standing Pasta Cooker
Single-well Pasta Cooker – Electric Rapid System

The company reserves the right to make modifications to the products without prior notice. All information correct at time of printing.