



Pasta Station 4-Basket Automatic Pasta Cooker

ITEM # _____

MODEL # _____

PROJECT NAME # _____

SIS # _____

AIA # _____



Pasta Station 4-Basket Automatic Pasta Cooker

168747 (7PCSE2AU)

4-Basket Automatic
Pasta Cooker
208 V/3p/60z - 27.5A

Short Form Specification

Item No. _____

Unit to be Electrolux 4-Basket Automatic Pasta Cooker 168747. The unit is a free-standing, 4-basket and automatic Pasta Cooker. Each basket is to be independently programmable and cooking times are microprocessor controlled. The water temperature is to be thermostat controlled and programmable. The unit shall feature constant water level and starch removal during cooking process. IPX4 (NEMA 4 equivalent) splash water protection. Two Stainless steel baskets included. The 10.5 gallon tank is pressed in AISI 316 Stainless steel and features only rounded corners. The unit to be completely in AISI 304 Stainless steel.

Covered by Electrolux Platinum Star™ Service Program two-year parts and one-year labor warranty, installation start-up and performance check-up after one year from installation.

Main features

- 4-baskets: independently controlled by push-buttons.
- Microprocessor controlled programmable cooking time for each basket.
- 10.5 gallon tank.
- Thermostat controlled programmable water temperature: for cooking, re-therming and sous-vides applications.
- 9 position energy regulator.
- Constant water level.
- Automatic starch removal function during cooking: improved water quality over time.
- Automatic low-water level shut-off: no accidental over-heating.
- Electrolux Platinum service package included:
 - 2-year parts, 1-year labor warranty, 5-year compressor warranty.
 - Start-up install check.
 - Equipment check-up after 12 month from installation.

Construction

- Pressed 10.5 gal capacity tank: only rounded corners for improved cleanability.
- AISI 316 Stainless steel tank: maximum corrosion resistance.
- All Stainless steel construction.
- IPX 4 splash water protection (NEMA 4 equivalent).
- 5", height adjustable legs.

Included Accessories

- 4 of AISI 304 Stainless steel baskets.

Optional Accessories

- Bulk cooking basket.
- 2 of 1/2 size bulk cooking baskets.
- 3 of 1/3 size bulk cooking baskets.
- 3 of round individual-portion baskets
- False bottom for round individual-portion baskets.
- Castors.



Approval: _____

Electrolux Professional, Inc.

www.electroluxusa.com/professional

3225 SW 42nd Street, Fort Lauderdale, Florida, 33312 • Telephone Number: 866-449-4200 • Fax Number: 954-327-6789



Electrolux

Pasta Station 4-Basket Automatic Pasta Cooker

Front View

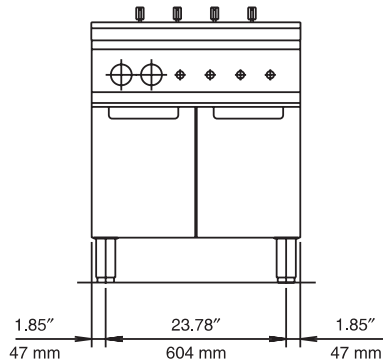

Top View

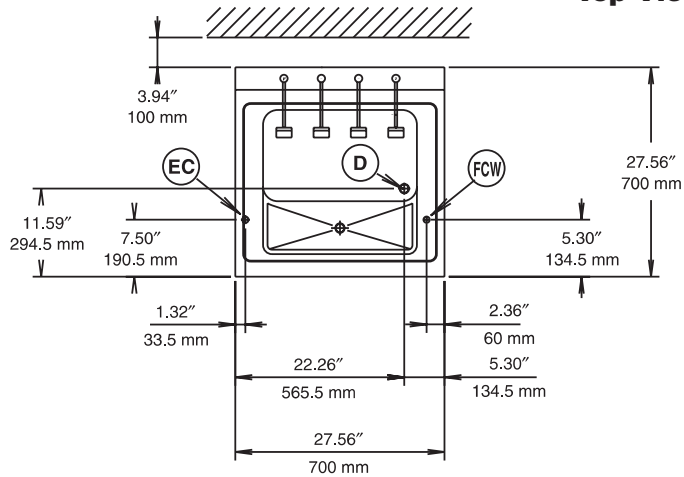

EC = Electrical connection
FCW = Filtered Cold Water Inlet
D = Water drain

Side View

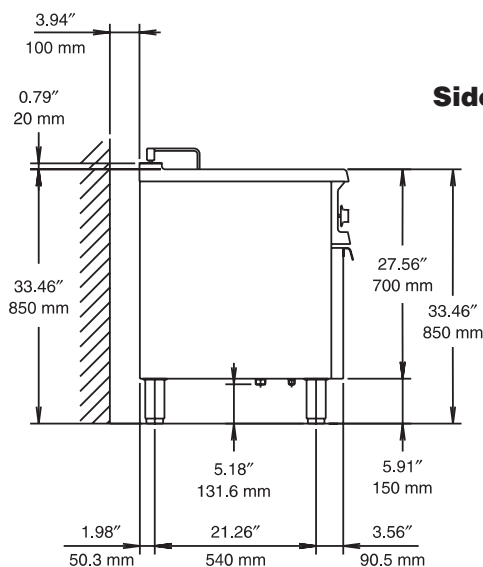

Electric

Supply voltage:
 168747 (7PCSE2AU) 208 V/3p/60Hz - 27.5A
Total Watts: 10 kW
Circuit breaker required:

Water

Water inlet "CW" – 1/2" connection:
Total hardness: 5-50 ppm
Drain "D" 1" connection
Electrolux recommends the use of treated water, based on testing of specific water conditions.
Please refer to user manual for detailed water quality information.

Installation

Clearance: 4" (10 cm) from back.

Capacity

Max.: 10.5 gal
Min.: 8.5 gal

Key Information

Net weight: 187 lbs. (85 kg)
Height, inch/mm: 33-7/16" (849 mm)
Width, inch/mm: 27-9/16" (700 mm)
Depth, inch/mm: 27-9/16" (700 mm)
Shipping weight: 203 lbs. (92 kg)
Shipping width: 33-1/16" (840 mm)
Shipping height: 45-11/16" (1160 mm)
Shipping depth: 32-1/4" (820 mm)
Shipping Volume: 28.25 cu. ft. (0.80 m³)