

Combination Vegetable Prep and Vertical Cutter-Mixer



Prepare 850 servings in 3 hours or less!

Vegetable prep attachment designed for quality continuous feed slicing, shredding, grating, french fry, and julienne. Accommodates 21 different processing discs. Bowl attachment designed for mixing, chopping, pureeing, and blending.



- 3 Qt. "stock pot" shaped, cutter bowl with handle and "S" blade.
- Standard model has gray ABS plastic bowl and see-thru lid. Clear and stainless steel bowls are available (R2N CLR - clear bowl and R2N Ultra - stainless steel bowl).
- Direct Drive, fan-cooled, 1 HP motor.
- Large range of 21 processing discs to choose from.
- Continuous feed vegetable prep attachment with two deep feed openings.
- Attachments easily removed for superior cleanability.
- Unit base uses minimal counter space (14 1/4" x 14 1/2").
- Standard package includes two processing discs (R209 - 2mm grating and R211 - 4mm slicing).
- 3 year motor warranty, 1 year parts and labor warranty.

Robot Coupe U.S.A., Inc.
P.O. Box 16625
Jackson, MS 39236-6625
1-800-824-1646 • (601) 898-8411
FAX: (601) 898-9134
www.robotcoupeusa.com
e-mail: info@robotcoupeusa.com

SPECIFICATIONS ON REVERSE SIDE

Specifications

STANDARD MODEL: Includes motor base unit, continuous feed attachment, discharge plate, one 5/32" (4mm) slicing disc, one 5/64" (2mm) medium grating disc and 3 Qt. bowl with handle and stainless steel smooth edge "S" blade.

ELECTRICAL REQUIREMENTS: 120V, 60HZ, 7 Amps.

SWITCHING: Control panel with push-type on and off, and pulse buttons.

MOTOR: 1 HP, 1725 RPM, direct-drive, fan-cooled.

WEIGHT: 27 lbs. net, 31 lbs. approximate shipping weight.

OPTIONAL EQUIPMENT: 19 additional processing discs and free standing multiple disc rack.

STANDARDS: ETL electrical & sanitation, cETL (Canada)

Available Discs

Slicing Discs

- R291 - 1/32" (1mm)
- R210 - 5/64" (2mm)
- R292 - 1/8" (3mm)
- R211 - 5/32" (4mm)
- R293 - 3/16" (5mm)
- R270 - 1/4" (6mm)

Ripple Cut Slicers

- R212 - 5/64" (2mm)

Graters

- R208 - 1/16" (1.5mm)
- R209 - 5/64" (2mm)
- R281 - 1/8" (3mm)
- R280 - 1/4" (6mm)
- R215 - 11/32" (9mm)
- R271 - Hard Cheese Grate

Pulping

- R294 - Fine pulping disc
- R295 - Pulping disc

Julienne

- R214 - 5/64" (2x2mm)
- R296 - 5/64" x 5/32" (2x4mm)
- R297 - 5/64"x1/4" (2x6mm)
- R288 - 5/32" (4x4mm)
- R213 - 1/4" (6x6mm)
- R298 - 5/16" (8x8mm)

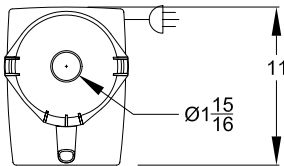

Bowl Unit

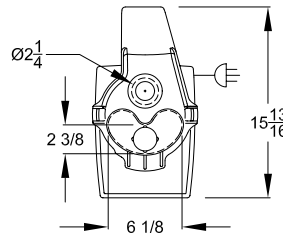

Continuous Feed Attachment

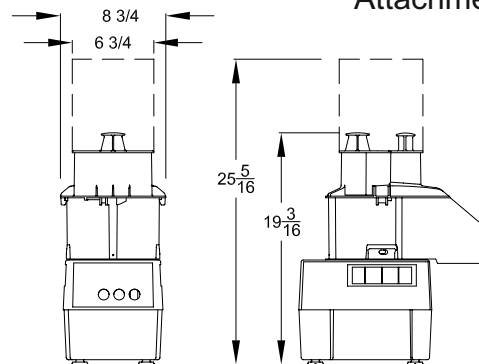
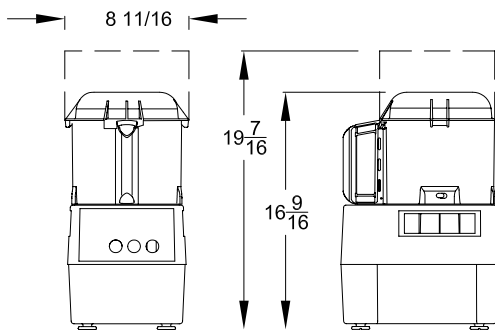

Robot Coupe U.S.A., Inc.
 P.O. Box 16625
 Jackson, MS 39236-6625
 1-800-824-1646
 (601) 898-8411
 FAX: (601) 898-9134
 www.robotcoupeusa.com
 e-mail: info@robotcoupeusa.com

Distributed by: