

## The **NEW R2DICE** from Robot Coupe



### **Prepare 850 servings in 3 hours or less!**

Vegetable prep attachment specially designed for quality, continuous feed **dicing, slicing, shredding, grating** and **julienne**. Accommodates 21 different processing plates and 3 different size dicing kits.

Bowl attachment designed for vertical cutting and mixing: **mix, chop, purée, blend, mix** and **knead doughs**.



- **3 quart "stock pot" shaped, cutter bowl with handle and "S" blade.**
- **Direct drive, fan-cooled 2 H.P. motor.**
- **Attachments easily removed for cleaning.**
- **Continuous feed vegetable prep attachment with two deep feed openings.**
- **See-thru lid.**
- **Comes with 2 stainless steel processing plates as standard plus 10mm dicing kit.**
- **"On-off" & pulse switches.**
- **3 year motor warranty.**
- **1 year parts and labor warranty.**

**Robot Coupe U.S.A., Inc.**

P.O. Box 16625

Jackson, MS 39236-6625

1-800-824-1646 • (601) 898-8411

FAX: (601) 898-9134

[www.robotcoupeusa.com](http://www.robotcoupeusa.com)

e-mail: [info@robotcoupeusa.com](mailto:info@robotcoupeusa.com)

**SPECIFICATIONS ON REVERSE SIDE**

## Specifications

**STANDARD MODEL:** Includes motor base unit with "on-off" pulse switch, 3 quart cutter bowl with handle and stainless steel "S" blade, continuous feed unit with discharge plate, one medium  $\frac{5}{64}$ " grating assembly, one  $\frac{5}{32}$ " slicing plate and 10mm dicing kit.

**ELECTRICAL:** 120V, 60 cycle, 13 Amps.

**MOTOR:** 2 H.P., capacitor-type, fan-cooled, single phase, 1725 R.P.M.

**SWITCHING:** "on-off" and pulse push type switch, that will not operate with bowl or cover off.

**BOWL CAPACITY:** 3 Quarts.

**WEIGHT:** 35 lbs. net, 37 lbs. approximate shipping weight.

**OPTIONAL EQUIPMENT:** 21 additional processing plates and 2 additional dicing kits. Free standing plate rack R255 holds 9 processing plates.

### PROCESSING PLATES:

#### Slicing Plates

- R210 -  $\frac{5}{64}$ " (2mm)
- R211 -  $\frac{5}{32}$ " (4mm)
- R270 -  $\frac{1}{4}$ " (6.5mm)
- R291 -  $\frac{1}{32}$ " (1mm)
- R292 -  $\frac{1}{8}$ " (3mm)
- R293 -  $\frac{3}{16}$ " (5mm)

#### Waved Slicing Plate

- R212 -  $\frac{1}{16}$ " (1.5mm)

#### Grating Plates

- R271 -  $\frac{1}{64}$ " (0.5mm) Hard Cheese
- R208 -  $\frac{1}{16}$ " (1.5mm) Fine
- R209 -  $\frac{5}{64}$ " (2mm) Medium
- R281 -  $\frac{5}{32}$ " (4mm) Medium Coarse
- R280 -  $\frac{1}{4}$ " (6.5mm) Coarse
- R215 -  $\frac{5}{16}$ " (8mm) Extra Coarse

#### Pulping Plates

- R294 -  $\frac{1}{64}$ " (.7mm) Pulping
- R295 -  $\frac{1}{32}$ " (1mm) Pulping

#### Julienne Plates

- R213 -  $\frac{1}{4}$ " (6.5mm)
- R214 -  $\frac{5}{64}$ " (2mm)
- R288 -  $\frac{5}{32}$ " (4mm)
- R296 -  $\frac{5}{64}$ " x  $\frac{5}{32}$ " (2x4mm)
- R297 -  $\frac{5}{64}$ " x  $\frac{1}{4}$ " (2x6mm)
- R298 -  $\frac{5}{16}$ " x  $\frac{5}{16}$ " (8x8mm)

#### Dicing Kits

- 27264 - 8mm Dicing Kit
- 27265 - 10mm Dicing Kit
- 27266 - 12mm Dicing Kit

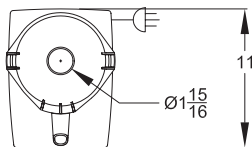

**BOWL UNIT**

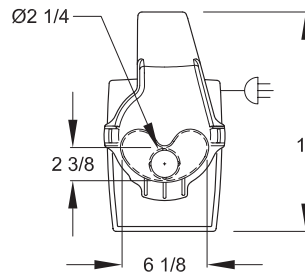
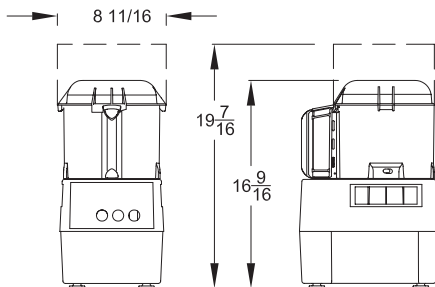

**CONTINUOUS FEED UNIT**

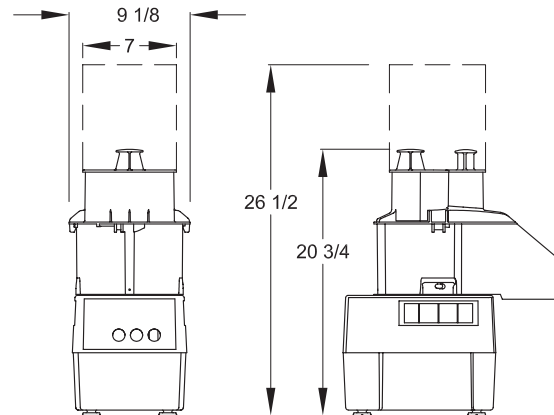

**Robot Coupe U.S.A., Inc.**

P.O. Box 16625

Jackson, MS 39236-6625

1-800-824-1646

(601) 898-8411

FAX: (601) 898-9134

www.robotcoupeusa.com

e-mail: info@robotcoupeusa.com

## Distributed by: