



BEVERAGE-AIR

PO Box 5932, Spartanburg, SC 29304
1-888-845-9800 Fax# 1-864-582-5083
<http://www.Beverage-Air.com>

Commercial Refrigeration Equipment General Specification

LUMAVUE SERIES—GLASS DOOR MERCHANDISER

Select from black or white exterior finish.
Used for merchandising and storage of product.

CABINET CONSTRUCTION

Heavy duty construction includes white epoxy coated steel interior walls. Exterior finish is heavy-duty steel with a baked on durable paint. Choose from black or white finish.

Foamed-in-place CFC free polyurethane insulation enhances the structural strength of the cabinet and helps increase energy efficiency.

Modern, one-piece grille is easily removed for cleaning and servicing.

Double pane, lowE argon glass doors feature inside and outside panes that are tempered for added safety.

Two sliding glass doors feature recessed, pocket door handles that provide low profile and is more aesthetically pleasing.

Four white epoxy coated steel shelves per door are standard.

Brightly lighted sign panel.

REFRIGERATION

Whisper-quiet refrigeration system uses R134a refrigerant, which is CFC-free for compliance with environmental safety concerns.

Operating temperatures from 35°F to 41°F.

ELECTRICAL

Interior fluorescent lighting enhances product illumination. Optional LED lighting provides hidden light source for increased product visibility. LED bulbs last up to 10 times longer compared to fluorescent bulbs and renders additional energy savings due to reduced wattage load on compressor.

Units wired at factory and ready for connection to a 115/60/1 phase, 15 amp dedicated outlet. 8' long cord and plug set included.

Item No. _____
Quantity _____

**SLIDING GLASS DOOR
LUMAVUE
MERCHANDISER SERIES
LV45**

**MODELS:
LV45**



LV45

(shown with optional Gravity Flo Kit and extra shelving)

SPECIAL FEATURES

- Sealed cavity
- Whisper-quiet refrigeration system
- Sliding glass doors
- Recessed, pocket door handles
- Brightly lighted sign panel
- Optional LED lighting
- 2010 Federal Energy Compliant
- Gravity Flo kits and Can Roller options available

ELECTRICAL CONNECTION



115/60/1
NEMA-5-15P

Units pre-wired at
factory and include 8'
long cord and plug set.



Available From:

Model Specified _____	Store# _____
Location _____	Quantity _____



LumaVue Glass Door Merchandisers
Model: LV45

MODEL	LV45
EXTERNAL DIMENSIONAL DATA	
Length Overall (inches) Length Overall (mm)	52" 1321
Depth Overall (inches) Depth Overall (mm)	32 3/8" 822
Height Overall— (inches) Height Overall— (mm)	78" 1981
Number of doors	2
Clear Door Opening (inches)	19 1/2" x 49 1/2"
INTERNAL DIMENSIONAL DATA	
NET Capacity (cubic ft.) NET Capacity (Liters)	46.96 1330
Internal Length Overall (inches) Internal Length Overall (mm)	49" 1245
Internal Depth Overall (inches) Internal Depth Overall (mm)	26" 660
Internal Height Overall—(inches) Internal Height Overall—(mm)	58" 1473
Number of shelves	8
ELECTRICAL DATA	
Full Load Amperes 115/60/1	10.6
ENERGY CONSUMPTION (KWH)	6.5
REFRIGERATION DATA	
Horsepower	1/2
WEIGHT DATA	
Gross Weight (Crated lbs)	533
Gross Weight (Crated kg)	242

PLAN VIEWS

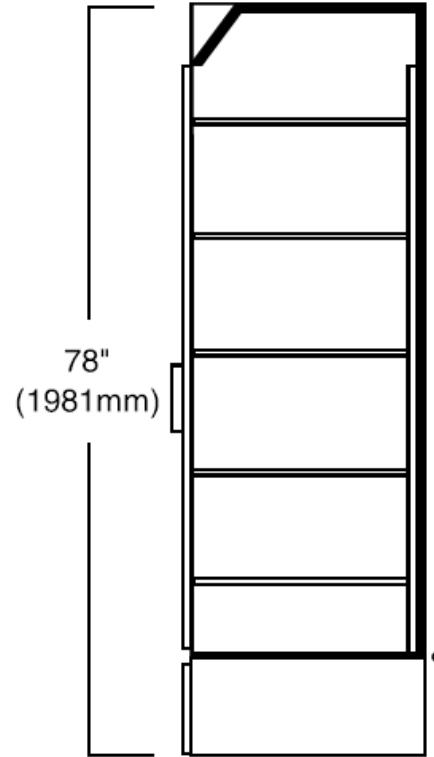

END VIEW

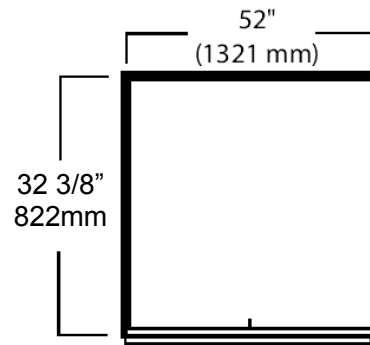

TOP VIEW



BEVERAGE-AIR® CORPORATION

700 Buffington Road • PO Box 5932 • Spartanburg, SC 29304 USA • (864) 582-8111 • Fax (864) 582-5083 • (888) 845-9800 • www.beverage-air.com