



BEVERAGE-AIR

PO Box 5932, Spartanburg, SC 29304
1-888-845-9800 Fax# 1-864-582-5083
<http://www.Beverage-Air.com>

Commercial Refrigeration Equipment General Specification

LUMAVUE SERIES—GLASS DOOR MERCHANDISER

Select from black or white exterior finish.
Used for merchandising and storage of product.

CABINET CONSTRUCTION

Heavy duty construction includes white epoxy coated steel interior walls. Exterior finish is heavy-duty steel with a baked on durable paint. Choose from black or white finish.

2" foamed-in-place CFC free polyurethane insulation enhances the structural strength of the cabinet and helps increase energy efficiency.

Modern, one-piece grille is easily removed for cleaning and servicing.

Double pane, lowE argon glass door features inside and outside panes that are tempered for added safety.

Self-closing, hinged glass door features recessed, pocket door handle provides low profile and is more aesthetically pleasing. Door features automatic hold-open feature.

Four white epoxy coated steel shelves are standard.

REFRIGERATION

Whisper-quiet refrigeration system uses R134a refrigerant, which is CFC-free for compliance with environmental safety concerns.

Operating temperatures from 35°F to 41°F.

ELECTRICAL

Interior fluorescent lighting enhances product illumination. Optional LED lighting provides hidden light source for increased product visibility. LED bulbs last up to 10 times longer compared to fluorescent bulbs and renders additional energy savings due to reduced wattage load on compressor.

Units wired at factory and ready for connection to a 115/60/1 phase, 15 amp dedicated outlet. 8' long cord and plug set included.

ELECTRICAL CONNECTION

Units pre-wired at factory and include 8' long cord and plug set.



115/60/1
NEMA-5-15P

Item No. _____
Quantity _____

GLASS DOOR LUMAVUE MERCHANDISER SERIES LV12

MODELS:
LV12



LV12

SPECIAL FEATURES

- Sealed cavity
- Whisper-quiet refrigeration system
- Recessed, pocket door handle
- Optional LED lighting
- 2010 Federal Energy Compliant
- Gravity Flo kits and Can Roller options available

Available From:



Model Specified _____	Store# _____
Location _____	Quantity _____



BEVERAGE-AIR

LumaVue Glass Door Merchandisers

Model: LV12

MODEL	LV12
EXTERNAL DIMENSIONAL DATA	
Length Overall (inches) Length Overall (mm)	24 1/2" 622
Depth Overall (inches) Depth Overall (mm)	24" 610
Height Overall— (inches) Height Overall— (mm)	62" 1575
Number of doors	1
Depth with Door Open 90 °	46 3/4"
Clear Door Opening (inches)	21 3/8" x 43 3/8"
INTERNAL DIMENSIONAL DATA	
NET Capacity (cubic ft.) NET Capacity (Liters)	11.12 315
Internal Length Overall (inches) Internal Length Overall (mm)	21" 533
Internal Depth Overall (inches) Internal Depth Overall (mm)	18 3/4" 476
Internal Height Overall—(inches) Internal Height Overall—(mm)	40" 1016
Number of shelves	4
ELECTRICAL DATA	
Full Load Amperes 115/60/1	4.6
ENERGY CONSUMPTION (KWH)	3.48
REFRIGERATION DATA	
Horsepower	1/6
WEIGHT DATA	
Gross Weight (Crated lbs)	230
Gross Weight (Crated kg)	104

PLAN VIEWS

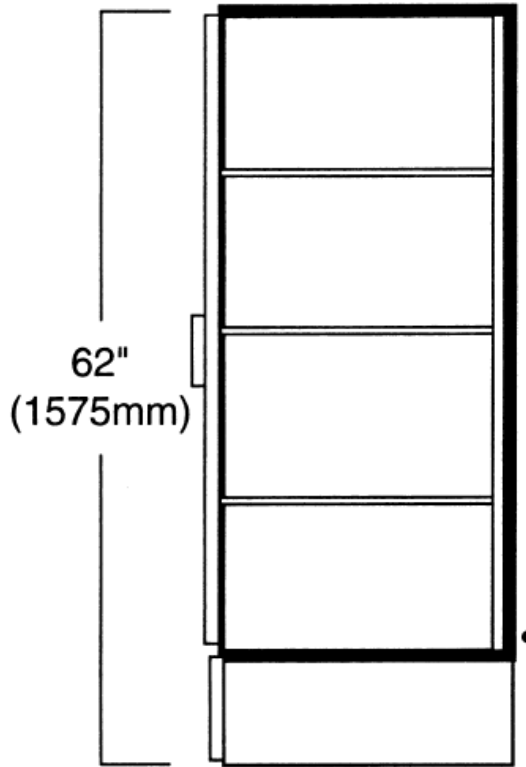

END VIEW

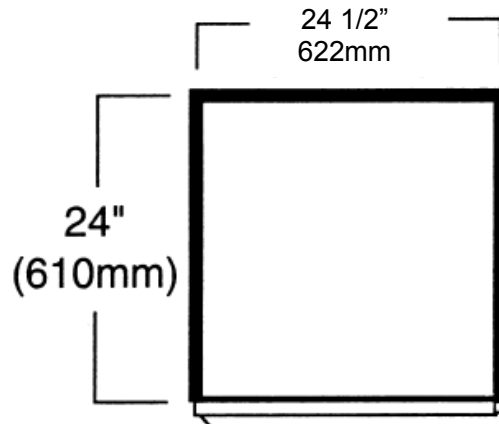

TOP VIEW



BEVERAGE-AIR® CORPORATION

700 Buffington Road • PO Box 5932 • Spartanburg, SC 29304 USA • (864) 582-8111 • Fax (864) 582-5083 • (888) 845-9800 • www.beverage-air.com