



SKILLETS

TILTING SKILLET, "SPASH PROOF" 10 GALLON, ELECTRIC TABLE TYPE, RECTANGULAR

MODEL: SET-10

Cleveland Standard Features

- Heat Element are cast integrally into 1.25" (32mm) thick aluminum blocks which are securely camped to the underside of the cooking surface, providing even heat distribution and energy efficiency with rapid heat-up
- Stainless Steel Cooking Surface is structurally braced to prevent warping
- Splash Proof
- Bead-blast Textured Cooking Surface Finish to reduce sticking
- Two Position Cooking Setting-Horizontal and 9° forward Tilt
- Skillet and Frame are Type 304 Stainless Steel Construction, with #4 Finish
- Thermostat Control conveniently located in a Drip Proof Side Console. Temperature Controlled from 190 °F (88°C) to 440°F (227°C)
- Sanitary Base Mounting for Table Top Installation
- Standard Voltage is 208-240 Volts, 60 Hz, 3 Phase, 3 Wire
- Lift-Off Cover

Options & Accessories

- Poaching Pans (PP)
- Vegetable Steamer (VS)
- Double or Single Water Faucet with Swing Spout (DPS) or (SPS)
- Stainless Steel Support Stands (ST28) with Sliding Drain Drawer and Splash Screen
- Voltages other than standard (VOS)
- Single phase option (SPH)
- Food Strainer (SF15)

ITEM NUMBER _____

JOB NAME / NUMBER _____



Shown with optional Support Stand (ST28)

Short Form Specifications

Shall be CLEVELAND 10 Gallons (40 liters) Model SET-10 ____ ; ____ KW ____ Volt, Rectangular Tilting Skillet of type 304 Stainless Steel Construction, with #4 Finish. Electric Heating Elements cast integrally onto 32mm thick aluminum blocks and securely clamped beneath cooking surface. Bead-Blast-Textured Cooking Surface. Complete with Thermostatic, Safety and Main Power Controls with Lighted Indicators. For Table Top Mounting. Lift-Off Cover.

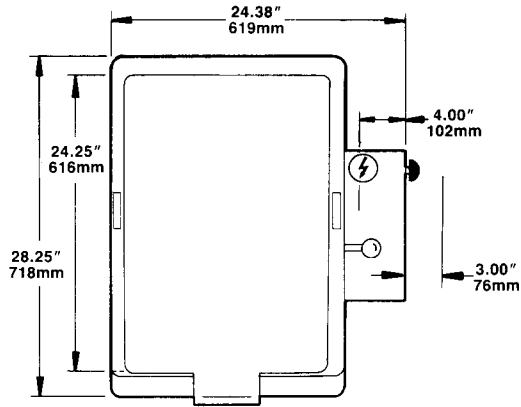

CAPACITIES

In 4 oz. servings. Other sizes may be calculated.
 10 gallons / 40 Liters 320

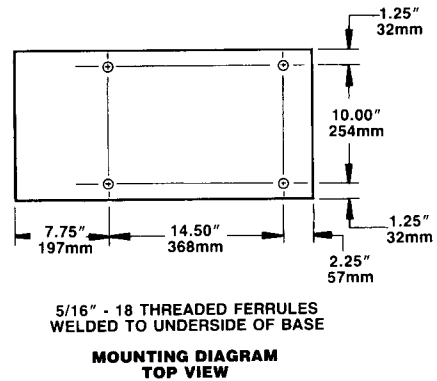
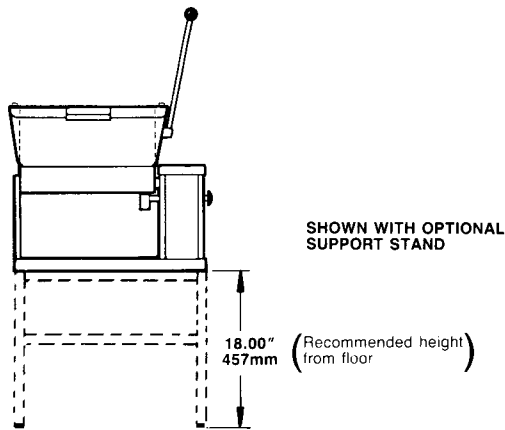
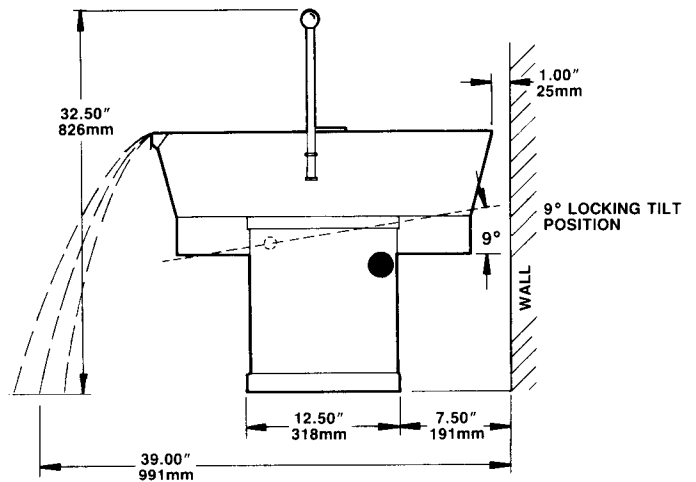
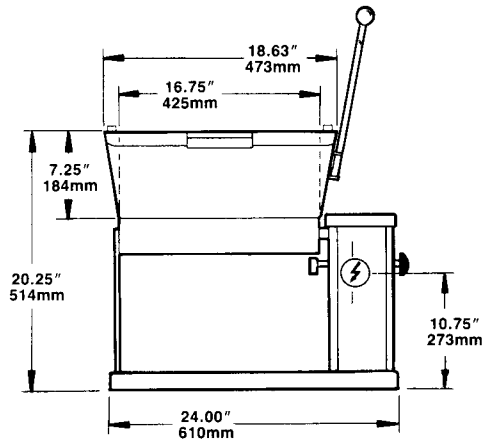

5/16" - 18 THREADED FERRULES
 WELDED TO UNDERSIDE OF BASE
**MOUNTING DIAGRAM
 TOP VIEW**

ELECTRIC ⚡												CLEARANCE	
		208 VOLTS			240 VOLTS			220 /380 VOLTS			RIGHT = 3.00" LEFT = 0" REAR = 1.00"		
		AMPS			AMPS			AMPS					
GALS.	LITERS	KW	1 PH	3 PH	KW	1 PH	3 PH	KW	1 PH	3 PH			
10	40	7.4	35.4	20.5	7.8	32.7	18.9	6.5	N/A	9.9			

DUAL VOLTAGE OF 220/380 SHOWN ON CHART REQUIRES A FOUR WIRE, THREE PHASE ELECTRICAL SUPPLY.

NOTES:

Cleveland Range reserves right of design improvement or modification, as warranted.
 Many regional, state and local codes exist and it is the responsibility of the owner and installer to comply with the codes.
 Cleveland Range equipment is built to comply with applicable standards for manufacturers. Included among those approval agencies are U.L., NSF, CGA, CSA, ETL and others.