



AX-M40
40 Quart Mixer

PROJECT _____
ITEM # _____
QUANTITY _____



AX-M40 40-QUART MIXER

The Axis Model AX-M40 is an advanced design, highly reliable professional food processing tool, and is ideal for mixing all types of dough, as well as eggs, cream, mayonnaise, etc. These all-purpose mixers use a powerful, planetary mixing action to thoroughly blend, mix and aerate all ingredients with consistent and predictable results.

STANDARD FEATURES	STANDARD ACCESSORIES
<ul style="list-style-type: none"> ★ 2 HP motor ★ Reliable and dependable gear drive design ★ Digital timer (0-30 min) ★ 3 speeds ★ Heat-treated hardened alloy steel gears and shaft ★ Stainless steel bowl guard ★ Side mounted controls (Timer, separate start and emergency stop button) ★ Silent operation ★ Highest quality aluminum alloy used for maximum standards of hygiene 	<ul style="list-style-type: none"> ★ 40 Quart S/S bowl ★ Aluminum flat beater ★ S/S wire whip ★ Aluminum dough hook
	<p style="text-align: center;">OPTIONAL ACCESSORIES</p> <ul style="list-style-type: none"> ★ VS Attachment (<i>housing only</i>) ★ Disks avail. for VS Attachment: (Shredder, grater and slicer disks) <i>Sold separately</i> ★ Meat mincer attachment



Model	Capacity	Motor	Amps	Speeds	Electrical
AX-M40	40 Quart	3 Speeds	12	152 / 313 / 573	220v / 60hz / 1ph

TECHNICAL DRAWING

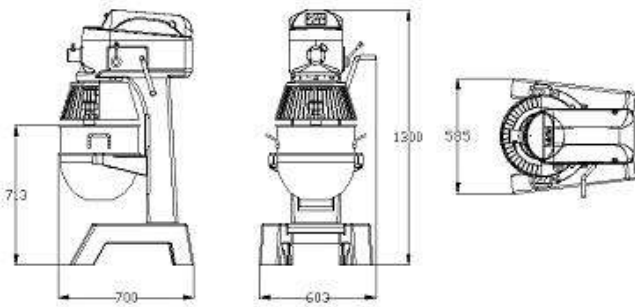

DIMENSIONS

Overall Width	= 23.7" (603mm)
Overall Depth	= 27.5" (700mm)
Overall Height	= 51.1" (1300mm)

WEIGHT

NET	= 441 lbs
SHIP	= 510 lbs

FREIGHT CLASS = 77.5

SPECIFICATIONS

★ Design

Heavy duty all purpose mixers use a powerful, planetary mixing action to thoroughly blend mix and aerate all ingredients with consistent results.

★ Stainless Steel Bowl Guard

Safety interlock prevents operation when front portion of guard is open.

★ Three Fixed speeds

Consistency, flexibility and reliability. Excellent for incorporating, blending and mixing ingredients. Provides consistent results throughout mixing.

★ Gear Transmission

Ensures consistent performance and minimum downtime under heavy loads.

★ 1.5 H.P. Motor

Meets the most demanding operations.

★ Electronic Digital Timer

Provides accurate and consistent results while indicating the length of mixing (in minutes) on digital timer.

★ Warranty

2 year parts and 1 year labor, exclusive of wear items

Due to our continued product improvement and striving for engineering excellence, specifications are subject to change without notice