



Standard Features

- 119 racks per hour hi-temp sanitizing rinse.
- 0.55 gallons per rack hi-temp sanitizing rinse.
- Incoming water pressure regulator
- Standard 18" clearance.
- Totally electro-mechanical; no solid state controls utilized.
- Fully automatic including auto-fill.
- Completely self-draining stainless steel wash pump.
- Exclusive "Energy Guard" controls system operates wash and rinse sections only when a rack is being washed or rinsed.
- A long 16" wash section as well as 18" separation between wash and rinse produces superior results.
- Convenient, externally operated lever drain.
- Stainless steel frame, legs, adjustable bullet feet, and front appearance panel are all standard.
- Standard 8" vent cowls/splash shields on both wash and rinse ends of the machine.
- Heavy gauge construction for extra ruggedness and durability.

Power/Connections

Approximate Total Load	AMPS
208V / 60HZ / 3PH	51.8
208V / 60HZ / 1PH	88.3
230V / 60HZ / 3PH	47.8
230V / 60HZ / 1PH	81.5
460V / 60HZ / 3PH	23.9

Booster Heater Options

External 40°F Min. Rise	KW	AMPS
208V / 60HZ / 3PH	24	66.6
230V / 60HZ / 3PH	24	60.2
460V / 60HZ / 3PH	24	30.1

External 70°F Min. Rise	KW	AMPS
208V / 60HZ / 3 PH	36	100.0
230V / 60HZ / 3PH	36	90.4
460V / 60HZ / 3PH	36	45.2

Venting Requirements (CFM)

Input end	200
Output end	400
Total CFM	600

Water Requirements

Incoming Water Temperature (°F)	180
With 24 KW booster heater option (°F)	140
With 36 KW booster heater option (°F)	110
Gallons per hour:	
Hi-temp sanitization	66
Gallons per rack:	
Hi-temp sanitization	0.55
Prewash Tank Capacity (Gallons)	17.25
Wash Tank Capacity (Gallons)	20.4
Incoming Waterline Sizes (IPS) (Minimum)	1/2
Flow Pressure (PSI)	15-25
Flow Rate Minimum (GPM)	
Hi-temp sanitization	3.9
Drainline Size IPS (Minimum) (Inches)	1 1/2

Performance/Capacities

Operating Capacity

Racks per hour	
Hi-temp Sanitization	119
Dishes per hour	
Hi-temp Sanitization	2975
Glasses per hour	
Hi-temp Sanitization	2975

Steam Coil Tank Heat

Steam Connection IPS (Inches)	3/4
Steam Flow Pressure (PSIG)	10-20
Consumption @ 15 PSIG (Lbs/hr)	60
Wash Pump Motor HP	2
Wash Pump Capacity (GPM)	270
Wash Tank KW	15

Prewash Pump Motor HP	1
Prewash Pump Capacity (GPM)	120
Conveyor Motor Horsepower	1/4
Conveyor Speed (Feet/minute)	
Hi-temp Sanitization	3.3

Operating Temperatures

Prewash Tank-°F	110 - 140
Wash Tank-°F (Minimum)	
Hi-temp Sanitization	160
Rinse-°F (Minimum)	
Hi-temp Sanitization	180

Dimensions (Inches)

Length between dishtables	66
Machine width	30-3/4
Wall Clearance (Minimum)	4
Cavity/dish clearance (Maximum)	18
Cavity width	20-1/2

Shipping Information

Weight (Lbs)	894
Dimensions (Inches)	
Length	96
Depth	40
Height	78
Volume (Cubic feet)	174

TSC-66 Traditional Series

Conveyors

Specifications

NOTE: The TSC-66 series conveyor dishmachines are NSF International Inc. (NSF) and Underwriters Laboratories Inc. (UL) listed. They also meet the requirements of A.S.S.E. Standard No. 1004.

PERFORMANCE: Fully automatic, single tank, rack conveyor dishwasher designed to wash, rinse, and sanitize tableware and utensils commonly associated with the preparation and consumption of food items in a commercial foodservice operation. Sanitization is accomplished through hi-temp sanitization utilizing 180-195°F fresh water rinse. The unit conveys standard 20" x 20" dishracks first through a recirculated (120 GPM) 110 - 140°F prewash and then through a recirculating detergent laden wash section where 270 gallons per minute (GPM) of 160°F wash water is pumped over the dishrack to remove the food soil. The rack is then conveyor driven into a final rinse section where a fresh water final rinse spray system removes residual detergent and sanitizes. For hi-temp sanitizing, the unit must be installed to a potable water line capable of supplying 66 gallons per hour between 180-195°F at 15-25 PSI flow pressure for maximum hourly rack capacity of 119 racks per hour.

CONSTRUCTION: All stainless steel components are 304 series stainless steel. No 400 series stainless steel and/or plastics are utilized. Frame is constructed of 2" diameter stainless steel tubing formed and completely saddle welded for superior strength. The wash tank, and rinse chamber are formed and heliarc welded 16 gauge #2B finish. Hood is 16 gauge #3 finish. Stainless steel feet are adjustable $\pm 1/2"$.

PREWASH PUMP: Internal prewash pump located inside the prewash tub is totally stainless steel as is the impeller. The prewash pump itself is totally integral with the motor. Prewash water is recirculated from the prewash tank through the manifolds and prewash arm system at the rate of 120 GPM.

WASH PUMP: Internal wash pump located inside the wash tub is totally stainless steel as is the impeller. The wash pump itself is totally integral with the motor. Wash water is recirculated from the wash tank through the manifolds and wash arm system at the rate of 270 GPM.

PREWASH PUMP MOTOR: A 1 HP totally enclosed, fan cooled type motor drives the wash pump and arms. Single-phase motors are capacitor start, induction run with internal thermal overload protection. Three-phase motors are induction run with external overload protection. Motor shaft is supported by permanently lubricated grease packed ball bearings.

WASH PUMP MOTOR: A 2 HP totally enclosed, fan cooled type motor drives the wash pump and arms. Single-phase motors are capacitor start, induction run with internal thermal overload protection. Three-phase motors are induction run with external overload protection. Motor shaft is supported by permanently lubricated grease packed ball bearings.

CONVEYOR SYSTEM: Racks are conveyed through the machine by a center-mounted, heavy-duty stainless steel pawl bar with stainless steel cast, counter-weighted, wide surface pawls. The pawl bar is designed to not interfere with spray patterns in the wash, and rinse section. The pawl bar is driven by a 1/4 HP motor and worm drive gear reduction unit. The conveyor motor itself is totally enclosed, non-ventilated. Single-phase motors are capacitor start, induction run with internal thermal overload protection. Three-phase motors are induction run with external overload protection. Pawl bar conveyor drive unit is mounted on the left hand side of the machine and is enclosed with a removable stainless steel cover. Maximum conveyor speed is 7.0 feet per minute for hi-temp machines.

CHAMBER: The chamber has a standard clearance of 18".

CONTROLS: Controls are located in a stainless steel control box mounted on top of the machine for ease of access and increased reliability. Power "ON/OFF" switch is the only manual switch required. "Energy Guard" fully automates the machine and utilizes switching logic to operate wash and rinse sections only when a rack is being washed or rinsed as well as turning the conveyor off when a rack exits the machine and there are no other racks in the machine. Regardless of machine voltage, all control circuitry will be operated from a 110 volt control circuit transformer. The unit is completely wired with 105°C, 600V thermoplastic insulated wire and routed through UL approved conduit.

FILL: Initial fill of the prewash tank and wash tank is automatic when the machine is initially energized. The prewash tank fill line needs to be hooked up to a 110 - 140°F potable water line; the wash tank fill line needs to be hooked up to a 180°F minimum potable water line which normally would be supplied by an external booster heater or our optional Hatco booster heater packages. Fill is controlled by standard solenoid valves and vacuum breaker assemblies. The incoming water solenoids are activated by stainless steel float systems located in the tanks for required maintenance of the water levels.

RECIRCULATING PREWASH: The prewash tank itself has a 17.25 gallon capacity and maintains the water level with a separate fill connection from the rest

of the machine. The automatic fill is controlled through an internal float and an external solenoid valve. Washing action is accomplished by recirculating water in the prewash tank through upper and lower prewash arms. All prewash arms are easily removable and along with removable end caps, are easily cleanable without the use of tools.

RECIRCULATING WASH: The wash tank itself has a 20.4 gallon capacity and maintains that level with a skimming type overflow. Washing action is accomplished by recirculating detergent laden water in the wash tank through upper and lower wash arms. Make-up water comes from the final rinse section and is controlled at approximately 2 GPM. The arms themselves are extended and create a longer wash section than competitive models. Wash section is automatically activated by racks as they pass through. Wash arms, upper and lower, contain 36 separate stripping nozzles for superior performance. All wash arms are easily removable and along with removable wash arm end caps, are easily cleanable without the use of tools. Large stainless steel strainer pans, as well as a pump intake strainer for secondary protection are readily accessible and removable for cleaning purposes. Knockouts and connections are provided to allow easy installation of detergent concentration sensor and dispenser tubing by others.

FINAL RINSE: Fresh pressurized rinse water enters the machine through a standard "Y" strainer, solenoid valve, and approved vacuum breaker assembly and is plumbed to upper and lower final rinse arms located at the output end of the machine. Single rows of fan jet nozzles are located on both rinse arms. Connection points are provided for both rinse agent injection into the final rinse line by others. Total final rinse flow rate is 3.9 GPM.

DRAIN, OVERFLOW, AND MAKE-UP: The machine is designed to maintain appropriate wash tank water levels at all times even at low pressures. The overflow system is designed to automatically skim the surface of the wash tank. Make-up water from the final rinse system not only replenishes the wash water but also helps maintain appropriate water levels as well as appropriate wash tank temperatures. A large lever located on the front panel of the machine operates a drain valve and drains the machine completely.

PRESSURE REDUCING VALVE: Factory installed on incoming water line to control water pressure.

Additional Standard Equipment:

- Vent cowls/splash shields with 4" x 16" openings covered with removable plates for connection to exhaust ducts when required.
- Flexible strip curtains provided at the ends of the vent cowls as well as at the ends of the machine and separating the prewash, wash, power rinse, and final rinse sections.
- Extra large inspection doors located on front of machine for easy access and cleanability.
- Safety door switches shut down machine should any door be opened during operation.
- Stainless steel front appearance panel.
- Positive low level water protection for wash and power rinse tank heat.
- Sealed dial type thermometers for the wash and final rinse temperatures.

Optional Mandatory Specifications:

WASH TANK HEATING EQUIPMENT (Choose One):

ELECTRIC: Low watt density 15 KW tubular heating elements mounted inside the wash tank and easily removable from the outside. The heaters are protected by a stainless steel float system as well as high limit overload protection. Water temperature in the tanks is controlled and maintained by fast reacting thermostats which control the heating elements.

STEAM: Stainless steel coils are utilized rather than injectors so that contaminated steam being injected into the wash water is not an issue. Stainless steel tubular steam coils are mounted inside the wash and power rinse tanks below the optimum water level. The coils are protected by a stainless steel float system. An external steam "Y" strainer and high temperature steam solenoid regulates the flow of steam through the coils. Temperature in the tanks is controlled and maintained by fast reacting thermostats which control the operation of the steam solenoids. A float and thermostatic steam trap is provided and removes steam condensate from the steam coils which can either be plumbed to a drain or pumped back to the boiler if a condensate return system is available. Steam coils require a minimum of 10 PSIG flowing steam supply and a maximum of 20 PSIG. Install with a steam pressure regulator (by others) if steam supply exceeds 20 PSIG.

Optional Features and Accessories:

EXTERNAL 40°F ELECTRIC BOOSTER HEATER: External 24 KW booster heater boosts incoming 140°F water to a minimum of 180°F for hi-temp sanitizing rinse. Custom features include castone-lined tank, low water cutoff, pressure relief valve, as well as a pressure reducing valve. Unit is located next to the output end of the machine, completely preplumbed. Power to the booster heater requires a separate electrical connection. Unless specified otherwise, electrical characteristics of the booster heater will be the same as that of the dishwasher. The booster heater is available in 208/240/480 voltages/3 phase only.

EXTERNAL 70°F RISE BOOSTER HEATER: External 36 KW booster heater capable of boosting incoming 110°F water a minimum of 70 degrees to a minimum of 180°F for hi-temp sanitizing rinse. Unit is located next to the output end of the machine and comes completely preplumbed. Power to the booster heater requires a separate electrical connection. Unless specified otherwise, electrical characteristics of the booster heater will be the same as that of the dishwasher. The booster heater is available in 208/240/480 voltages/3 phase only.

STEAM BOOSTER HEATER: Sized to be connected to a standard 110°F incoming water supply in order to insure 180-195°F hi-temp sanitizing final rinse requirements. Unit comes complete with steam "Y" strainer and high temperature steam solenoid as well as a steam pressure relief valve. Water temperature is controlled and maintained by a fast reacting thermostat which controls the operation of the steam solenoid. A float and thermostatic steam trap is provided and removes steam condensate from the coil which can either be plumbed to a drain or pumped back to a boiler if a condensate return system is available. Must be installed with a steam pressure regulator (by others) if steam supply exceeds 20 PSIG.

TABLE LIMIT SWITCH: Factory wired to machine and mounted to the backsplash of the table in the field. Prevents damage to conveyor drive system, racks, and dishes due to racks backing up on the output end of the machine. Highly recommended for clean dishtables less than 10 feet in length.

VENT COWL COLLARS: Factory installed 4" x 16" x 7" high collars located on the vent cowls to allow easy connection to an external exhaust system including a standard "pant-leg" type exhaust duct. Includes adjustable and lockable damper flap for fine tuning exhaust system to remove appropriate CFM requirements.

50 CYCLE (HERTZ) ELECTRICAL CHARACTERISTICS: Units are available in 50 HZ

in the following voltages: 208V/1 or 3PH, 230V/1 or 3PH, 380V/3PH, and 460V/3PH. Units operating at 50 HZ are not submitted for UL Listing.

SIDELOADER: Factory installed option on input end of conveyor machine. This feature allows the machine to be installed close to a corner and maximize dishroom space. The sideloader option is available in both the hooded and unhooded versions. See separate spec sheets for details.

EXHAUST VENT FAN CONTROL: Automatically turns exhaust vent fan on when rack enters the machine. Delay timer also turns off the exhaust vent fan 5-10 seconds after rack exits machine when no other racks are being conveyed through the machine.

FLANGED FEET: Available for installations where permanent mounting to the floor is required. Fully adjustable for required height.

WATER HAMMER ARRESTOR: Installed inside the supply line.

TSC-66 Traditional Series

Conveyors

Specifications

Note: Check and/or copy all that apply.

TS-66 Series Rack Conveyor Dishwasher - Item No. _____

Shall be a Jackson TS-66 series, single tank rack conveyor dishwasher. Sanitization shall be accomplished by using:

_____ Hi-temp (180°F minimum) sanitizing rinse

Electrical characteristics shall be:

_____ 208V/60HZ/3PH _____ 208V/50HZ/3PH

_____ 208V/60HZ/1PH _____ 208V/50HZ/1PH

_____ 230V/60HZ/3PH _____ 230V/50HZ/3PH

_____ 230V/60HZ/1PH _____ 230V/50HZ/1PH

_____ 460V/60HZ/3PH

Wash tank heating shall be a minimum of 160°F for hi-temp applications and accomplished by:

_____ 15 KW electric heating elements thermostatically controlled.

_____ Stainless steel steam coils thermostatically controlled.

Direction of rack flow shall be (when standing in front of machine):

_____ Right-to-Left _____ Left-to-Right

Unit shall have the following features:

- 252 racks per hour utilizing 0.74 gallons of water per rack for hi-temp sanitizing rinse.
- Incoming water pressure regulator.
- Standard 18" clearance throughout machine.
- Exclusive "Energy Guard" controls system energizes prewash, wash, recirculating rinse, and final rinse sections only when a rack is in place.
- Completely electro-mechanical; no solid-state controls.
- Fully automatic operation including auto-fill.
- Stainless steel wash pump and impeller and completely self-draining.
- Wash section must be a minimum of 16" in length as well as 18" separation between recirculating wash and final rinse.
- Convenient, externally operated lever drain.
- Vent cowls/splash shields with extra curtains on both wash and rinse ends of the machine.
- Stainless steel frame, legs, adjustable bullet feet, and front appearance panel.
- All 304 series stainless steel construction; no 400 series stainless steel and no plastics utilized.

Unit shall have the following features as optional extras:

_____ External electric 24 KW booster heater for a minimum 40°F rise and available in the following voltages:

_____ 208V/50 or 60HZ/3PH

_____ 240V/50 or 60HZ/3PH

_____ 480V/50 or 60HZ/3PH

_____ External electric 36 KW booster heater for a minimum 70°F rise and available in the following voltages:

_____ 208V/50 or 60HZ/3PH

_____ 240V/50 or 60HZ/3PH

_____ 480V/50 or 60HZ/3PH

_____ Steam booster heater.

_____ Exhaust fan control controls external exhaust fan power and duration time.

_____ Flanged feet for permanent in-place mounting to the floor.

_____ Table limit switch completely prewired and extending from the output end of the machine, 15'0" long.

_____ Whisker-style switch

_____ Striker plate switch

_____ Photosensor switch

_____ Installed 4" x 16" x 7" high vent cowl collars for easy connection to an external exhaust system and including adjustable and lockable damper flaps.

_____ output end only _____ input end only

_____ both ends

_____ Incoming water hammer arrestor installed.

_____ Sideloader installed on input end of machine.

_____ unhooded sideloader _____ hooded sideloader

 **Jackson**

www.jacksonmsc.com

1-888-800-5672



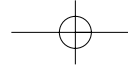

TSC-66 Traditional Series



Right to Left Operation Shown

Approximate Total Load Amps

TSC-66 Series Electrical Data	Electric Tank Heat Models: TSC-66		Steam Tank Heat Models: TSC-66S		Optional 24 KW Electric Booster Heater	Optional 36 KW Electric Booster Heater
	1-PH	3-PH	1-PH	3-PH	*3-PH	*3-PH
208 Volts 60 Cycles	88.3	51.8	18.3	10.1	66.6	99.9
230 Volts 60 Cycles	81.5	47.8	18.3	10.1	60.2	90.4
460 Volts 60 Cycles	N/A	23.9	N/A	5.1	30.1	45.2

Legend to Drawing

- A**– Machine water inlet 1/2" I.P.S., 180°F minimum, 61-1/4" above finished floor
- B**– Electrical connection, approximately 61-1/4" above finished floor. See table for amperage requirements
- C**– Drain connection-1 1/2" I.P.S.
- D**– Prewash water inlet 1/2" I.P.S. 110°F-140°F
- E**– Condensate return connection, 3/4" FPT (return to boiler feeder or open drain)
- F**– Incoming low pressure steam connection, 3/4" FPT (gate valve supplied)
- *Steam tank heat option only
- Note:** All vertical dimensions are +/- 1/2" from floor due to adjustable bullet feet

* Option electric boosters come in 3 phase only.

Note: Optional booster heater requires separate electrical connection. 24 KW and 36 KW booster heaters are designed to supply the dishmachine with rinse water at the appropriate temperature. Models do NOT come with booster heaters as standard equipment.

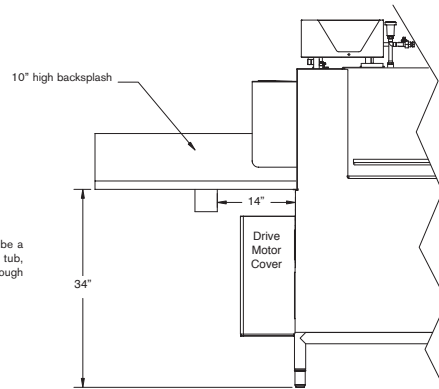

Scrap trough location MUST be a minimum of 14" from the tub, regardless of which side the trough is mounted on.

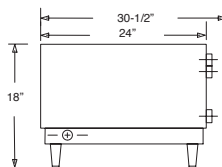

All specifications subject to change without notice.

The maximum recommended distance between any electric booster heater and the dishmachine is 20 ft.

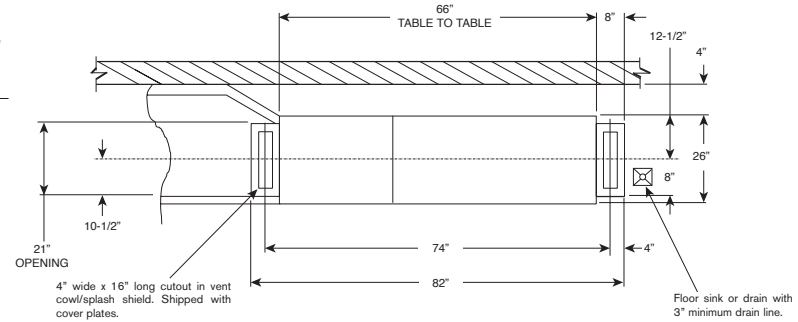

Recommended Table Fabrication

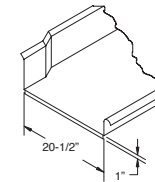

Scrap Trough Location

Machine height with doors open is 72".

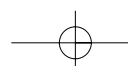
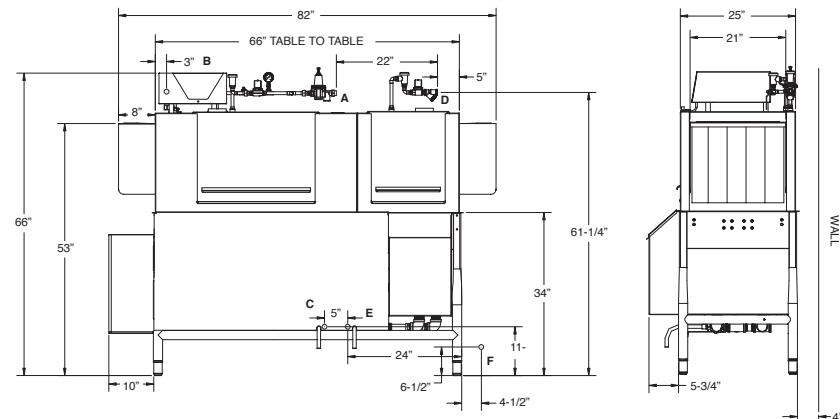

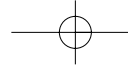

TSC-66 Traditional Series



Left to Right Operation Shown

Legend to Drawing

- A** - Machine water inlet 1/2" I.P.S., 180°F minimum, 61-1/4" above finished floor
 - B** - Electrical connection, approximately 61-1/4" above finished floor. See table for amperage requirements
 - C** - Drain connection-1 1/2" I.P.S.
 - D** - Prewash water inlet 1/2" I.P.S. 110°F-140°F
 - E** - Condensate return connection, 3/4" FPT (return to boiler feeder or open drain)
 - F** - Incoming low pressure steam connection, 3/4" FPT (gate valve supplied)
- *Steam tank heat option only
Note: All vertical dimensions are +/- 1/2" from floor due to adjustable bullet feet

Approximate Total Load Amps

TSC-66 Series Electrical Data	Electric Tank Heat Models: TSC-66		Steam Tank Heat Models: TSC-66S		Optional 24 KW Electric Booster Heater	Optional 36 KW Electric Booster Heater
	1-PH	3-PH	1-PH	3-PH	*3-PH	*3-PH
208 Volts 60 Cycles	88.3	51.8	18.3	10.1	66.6	99.9
230 Volts 60 Cycles	81.5	47.8	18.3	10.1	60.2	90.4
460 Volts 60 Cycles	N/A	23.9	N/A	5.1	30.1	45.2

* Option electric boosters come in 3 phase only.

Note: Optional booster heater requires separate electrical connection. 24 KW and 36 KW booster heaters are designed to supply the dishmachine with rinse water at the appropriate temperature. Models do NOT come with booster heaters as standard equipment.

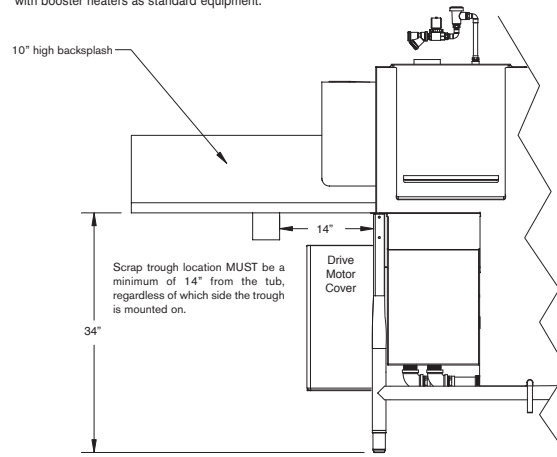

Machine height with doors open is 72".

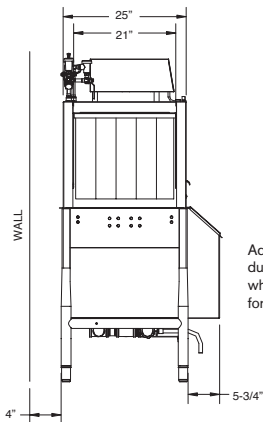

Add 3" to machine width to account for conduit and/or piping on the back of the machine when determining doorways and entrances for the machine to fit through.

The maximum recommended distance between any electric booster heater and the dishmachine is 20 ft.

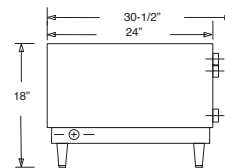

All specifications subject to change without notice.

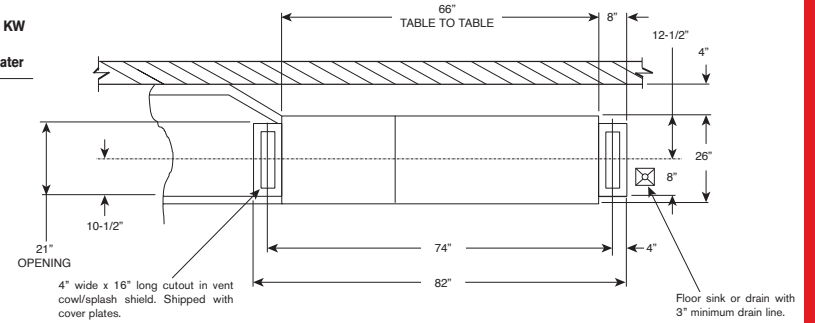

Recommended Table Fabrication

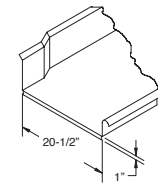

Scrap Trough Location

