



## Standard Features

- 10 gallons per hour
- 1800 - 2 1/2" glasses per hour
- 3 precision dispensers for detergent, rinse additive, and sanitizer
- 208-230/60 HZ / single phase / 20 amps total load
- Automatic conveyor system
- Wash and rinse temperature gauges
- Powerful 3/4 HP wash motor
- 100% fresh water rinse which eliminates rinse water contamination problems
- Low water protection on wash tank heating element
- Single switch operation
- Removable end plugs on wash and rinse arms for easy cleanability
- Heavy duty stainless steel construction
- Interchangeable upper and lower wash and rinse arms
- Automatic fill during cycle
- Stainless steel main frame
- Adjustable bullet feet
- Optional waste accumulator tray
- Available in clockwise or counter clockwise rotation—must specify

## Power/Connections

### Electrical Requirements

Electric Tank Heat KW	
208	2.7
230	3.3
Wash Pump Motor Horsepower	3/4

### Water Requirements

Gallons per Hour (Hot)	10
Flow Pressure (PSI)	15-25
Flow Rate (GPM)	2.6
Inlet Temperature °F (Hot)	130
Inlet Temperature °F (Cold)	70
Waterline Size IPS (Minimum) (Inches)	1/2
Drainline Size (Minimum) (Inches)	2

### Sanitizers Available

Sodium Hypochlorite	50 PPM
Iodiphor	12.5 PPM

## Performance/Capacities

### Operating Capacity

Glasses per Hour (2 1/2")	1800
---------------------------	------

### Operating Cycle (Seconds)

Total Cycle	120
-------------	-----

### Operating Temperatures

Wash (Minimum) °F	130
Rinse °F	70

### Tank Capacity (Gallons)

	4.14
--	------

### Wash Pump Capacity (GPM)

	55
--	----

### Dimensions (Inches)

Width	30 5/16
Depth	30 1/2
Height	39
Wall Clearance (Minimum)	2
Inside Clearance (Height)	10

### Shipping Weight (Lbs.)

	350
--	-----

### Shipping Size (Inches)

Width	33
Depth	33
Height	42

## Short Form Specifications

Item No. \_\_\_\_\_

Unit shall be Jackson Model R-30 chemical sanitizing glasswasher. Electrical characteristics to be 208 or 230 volts / 60 cycles / single phase operation with a 2 minute automatic cycle using 10 gallons of 70°F. minimum final rinse water per hour.

Stainless steel construction to include frame, wash tank, top and side panels. A 3/4 HP motor mounted to a cast iron pump with a stainless steel impeller shall be mounted to the machine frame. As standard the unit shall include:

- Capacity of 1800 2 1/2" glasses per hour
- Gravity drain
- Electro-mechanical components.
- Automatic conveyor system.
- Automatic fill
- Three (3) Chemical dispensing pumps
- Available in either Clockwise or Counter Clockwise rotation.
- Single switch operation

Unit shall be NSF and UL Approved.

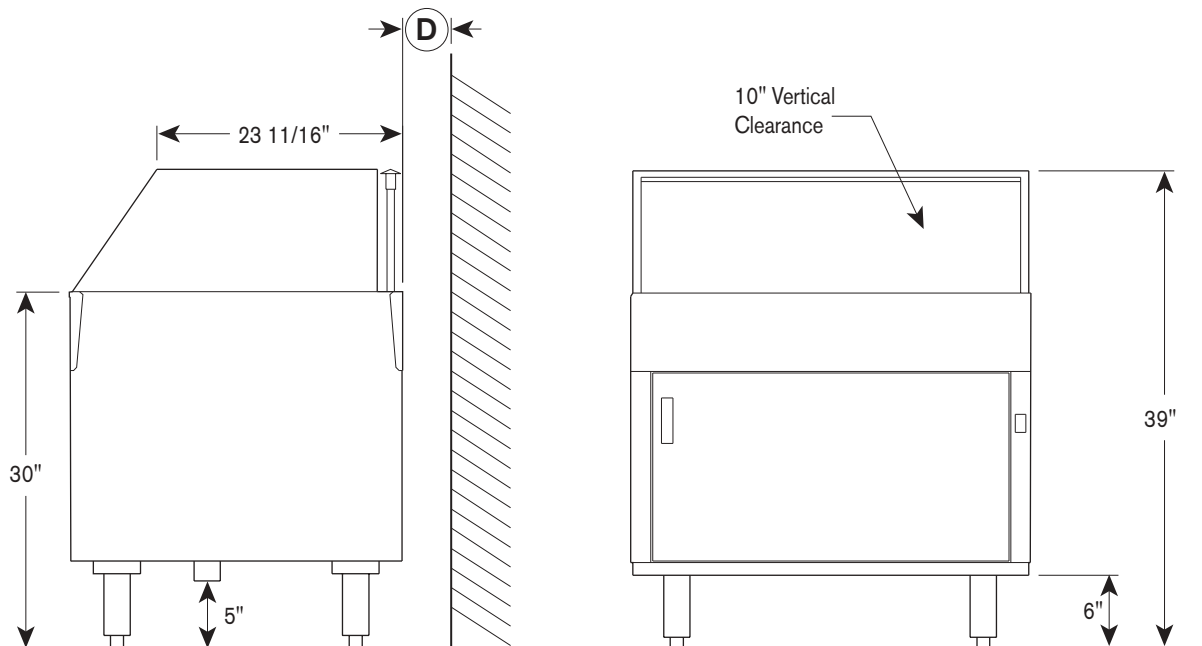
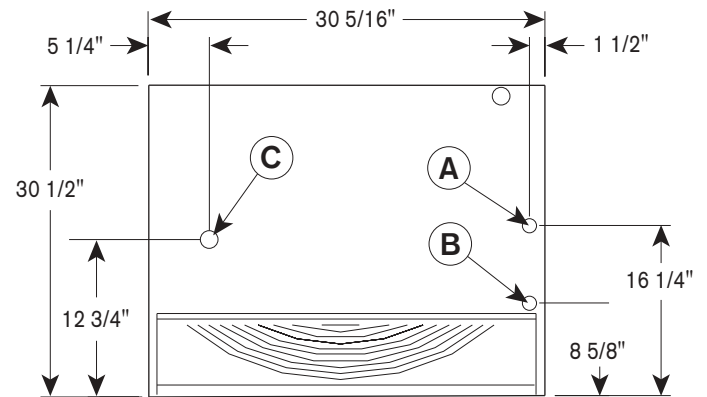

### LEGEND:

- A** – Water inlet 1/2" I.P.S. cold
- B** – Water inlet 1/2" I.P.S. hot
- C** – Drain 2" nominal, 5" from floor
- D** – Standard wall clearance 2"

All dimensions in inches.

All vertical dimensions are +/- 1/2" from floor due to adjustable bullet feet.

### Approximate Total Load Amps

208/60/1	18
230/60/1	19.4

www.jacksonmsc.com  
1-888-800-5672



07610-002-66-58

All specifications subject to change without notice.