

Jackson

Delta[®] 5

Project _____
 Item _____
 Quantity _____
 CSI Section 11400 _____
 Approval _____
 Date _____

Delta[®] 5

Models

Delta[®] 5



Standard Features

- ENERGY STAR[®] qualified
- Functions as both a glass-washer and a dishwasher, accommodating wares up to 11-1/2" (292 mm) high
- Push-button start
- Automatic fill, cycle and drain
- Solid-state timer
- Easily accessible controls
- 3-way dispensing system for detergent, rinse additive and sanitizer
- Stainless steel wash pump
- Lower rotary wash arm and fixed upper jets
- Door safety switch
- Adjustable bullet feet
- Swing-out control box for easy service and access
- Side control panel for easy access to switches
- Dial temperature gauge for constant monitoring of temperature
- Side skirt panels
- Latch-type front (lower) panel
- Delime/manual wash switch

Options

- Water Hammer Arrestor
- Scale Prevention System (SPS)
- Replacement cartridge for SPS (2-pack)

Accessories

- 36-Compartment Rack
 - 4-1/8" tall (105 mm)
 - 5-5/8" tall (143 mm)
 - 7" tall (178 mm)
- Combination Rack
- Peg Rack
- Flat Rack
- Half Rack

Specifications

Uses only 1.16 gallons (4.39 liters) of water per cycle	11-1/2" (292 mm) wash chamber clearance
Cleans 40 racks per hour	Gravity drain
1,440 glasses per hour	Built-in waste accumulator
90-second operating cycle	Sustaining heating element maintains final rinse between 120°F (49°C) and 140°F (60°C)
Powerful 3/4 hp wash pump motor	Removable end plugs on lower wash arm and removable upper jets
Built-in chemical pumps	Durable 304 stainless steel construction
Air-gap water inlet	



SHIPPING ADDRESS
 6209 North U.S. Highway 25E
 Gray, KY 40734

MAILING ADDRESS
 P.O. Box 1060
 Barbourville, KY 40906

Tel: 1-888-800-5672
 Fax: 606-523-1799
 info@jacksonmsc.com

www.jacksonmsc.com



OVERHEAD VIEW

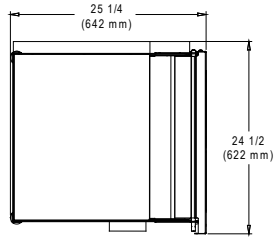

- A - Incoming Water Connection
- B - Drain Connection - 2" IPS
- C - Electrical Connection Point

NOTE: All vertical dimensions are at lowest point due to adjustable bullet feet and may be raised an additional 2 3/4".

SIDE VIEW

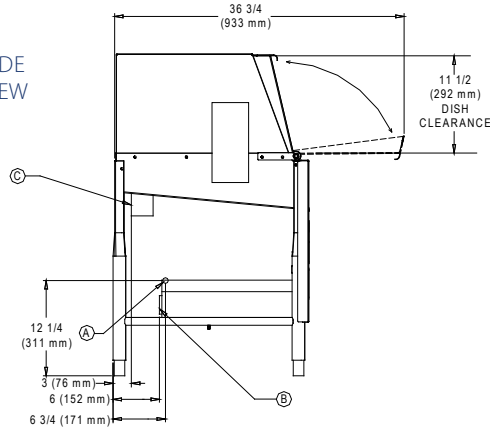

FRONT VIEW

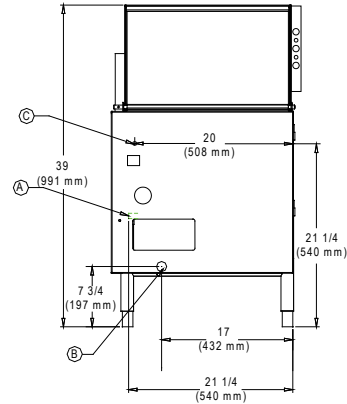

MODEL NO.	MACHINE DIMENSIONS				WALL CLEARANCE	SHIPPING INFORMATION					
	INSIDE CLEARANCE HEIGHT	INSIDE CLEARANCE WIDTH	INSIDE CLEARANCE DEPTH	DOOR OPEN DEPTH		WEIGHT	CLASS	CUBE	HEIGHT	WIDTH	DEPTH
Delta® 5	11-1/2" (292 mm)	20-1/4" (514 mm)	20-1/2" (521 mm)	36-3/4" (933 mm)	2" (51 mm)	210 lbs (95 kg)	92.5	28.2 cu. ft.	51" (1295 mm)	29" (737 mm)	33" (838 mm)

APPROXIMATE TOTAL LOAD AMPS	
115/60/1	16.0

OPERATING CAPACITY	
Racks Per Hour	40
Dishes Per Hour	1,000
Glasses Per Hour	1,440

ELECTRICAL REQUIREMENT	
Rinse Booster Tank Heater	2.0 kW
Wash Pump hp	3/4

OPERATING CYCLE	
Wash Cycle (Seconds)	43
Rinse Time (Seconds)	24
Dwell Time (Seconds)	18
Total Cycle (Seconds)	85

WATER REQUIREMENTS	
Gallons Per Hour	46.4 gal (176 L)
Flow Rate GPM	6.33 gal (24 L)
Flow Pressure (PSI)	15 - 25
Waterline Size (IPS)	1/2"
Drainline Size OD	2"
Tank Capacity	1.16 gal (4.39 L)
Wash Pump Capacity (GPM)	61 gal (231 L)
SANITIZERS AVAILABLE	
Sodium Hypochlorite	50 PPM
Iodophor	12 PPM

OPERATING TEMPERATURES	
Wash (Minimum)	120°F (49°C)
Wash (Recommended)	140°F (60°C)

HOW TO SPECIFY: Delta® 5

SHIPPING ADDRESS
6209 North U.S. Highway 25E
Gray, KY 40734

MAILING ADDRESS
P.O. Box 1060
Barbourville, KY 40906

Tel: 1-888-800-5672
Fax: 606-523-1799
info@jacksonmsc.com

www.jacksonmsc.com
07610-003-61-07 (02/10)

