



## Standard Features

### Model 10A

- Total automatic cycle 72-second cycle
- Automatic and manual controls
- Electric wash tank heat with low water protection
- Incoming water pressure regulator
- External vacuum breaker
- Exclusive counter rotating wash arms provide superior wash action
- Round design distributes even wash action giving superior results
- Heavy duty construction for years of reliable service
- 304 stainless steel
- Must be connected to a 180°F minimum potable water source for sanitizing rinse

### Model 10AB

All the standard features listed for the Model 10A plus a 6.5 KW built-in booster heater. The booster heater is sized to raise incoming water 40°F to 50°F and is thermostatically controlled to maintain proper sanitizing temperature. The Model 10AB must be connected to a 140°F minimum potable water source to guarantee proper sanitizing rinse.

### Model 10APRB

All the standard features listed for a Model 10AB plus a 1/2 HP pump to ensure proper flow pressure during the rinse cycle. The Model 10APRB is designed for areas of low and/or fluctuating water pressure and is highly recommended for facilities on well water systems and anywhere flow pressure is below 15 PSI. The Model 10APRB must be connected to a 140°F minimum potable water source to guarantee proper sanitizing rinse.

## Power/Connections

### Electrical Rating

Wash Pump Motor Horsepower	1/2
Rinse Pump Motor Horsepower (APRB only)	1/2
Electric Wash KW	0.75
Electric Wash Rinse KW	6.5

### Water Requirements

	Inlet Temperature °F
Model 10A	180
Model 10AB	140
Model 10APRB	140
Gallons per Hour	58
Waterline Size IPS (Minimum) (Inches)	1/2
Drainline Size IPS (Minimum) (Inches)	1 1/2
Flow Pressure PSI	15-25
Flow Rate GPM	7.8

## Performance/Capacities

### Operating Capacity

Racks per Hour	45
Dishes per Hour	630
Glasses per Hour	1260

### Operating Cycle (Seconds)

Wash Time	60
Rinse Time	10
Dwell Time	2
Total Cycle	72

### Operating Temperatures

Wash – °F (Minimum)	150
Rinse – °F (Minimum)	180

### Tank Capacity (Gallons)

Wash Tank	4.5
Booster Tank	3.0

### Pump Capacity (GPM)

### Dimensions (Inches)

Width	35 1/2
Depth	24 1/4
Height	58 1/4
Standard Table Height	34
Maximum Clearance	17 1/4

### Standard Racks Supplied

17 1/2" diameter round	
Dish	1
Glass and Silver	1
Four Compartment Silver	1

### Shipping Weight (Lbs.)

	200
--	-----

### Shipping Size (Inches)

Width	42
Depth	33
Height	73

# 10 Series

# Round

## Short Form Specifications

**Model 10A** – Item No. \_\_\_\_\_

Unit shall be Jackson Model 10A round hot water sanitizing dishmachine. Electrical characteristics to be \_\_\_ volts / 60 cycles / 1 phase operation with a 72 second automatic cycle using 58 gallons of 180° F. final rinse water per hour. Stainless steel construction to include hood, frame, wash tank, and adjustable feet. A 1/2 HP motor mounted to a cast iron pump with a stainless steel impeller shall be mounted to the machine frame. As standard the unit shall include:

- Single point connections for all utilities
- Side mounted control box with electro-mechanical components and a delimiting switch as standard.
- Automatic and manual controls
- Manual fill
- Built-in water pressure regulator.

Unit shall be NSF Certified and UL Listed.

**Model 10AB** – Item No. \_\_\_\_\_

Unit shall be Jackson Model 10AB round hot water sanitizing dishmachine. Electrical characteristics to be \_\_\_ volts / 60 cycles / \_\_\_ phase operation with a 72 second automatic cycle using 58 gallons of 180° F. final rinse water per hour. Stainless steel construction to include hood, frame, wash tank, and adjustable feet. A 1/2 HP motor mounted to a cast iron pump with a cast iron impeller shall be mounted to the machine frame. As standard the unit shall include:

- Built-in 6.5 KW booster heater
- Single point connections for all utilities
- Side mounted control box with electro-mechanical components and a delimiting switch as standard.
- Automatic and manual controls
- Manual fill
- Built-in water pressure regulator.

Unit shall be NSF Certified and UL Listed.

**Model 10APRB** – Item No. \_\_\_\_\_

Unit shall be Jackson Model 10APRB round hot water sanitizing dishmachine. Electrical characteristics to be \_\_\_ volts / 60 cycles / \_\_\_ phase operation with a 72 second automatic cycle using 58 gallons of 180° F. final rinse water per hour. Stainless steel construction to include hood, frame, wash tank, and adjustable feet. A 1/2 HP motor mounted to a cast iron pump with a cast iron impeller shall be mounted to the machine frame. As standard the unit shall include:

- Built-in 6.5 KW booster heater
- 1/2 HP pump to increase the final rinse flow pressure
- Single point connections for all utilities
- Side mounted control box with electro-mechanical components and a delimiting switch as standard.
- Automatic and manual controls
- Manual fill
- Built-in water pressure regulator.

Unit shall be NSF Certified and UL Listed.

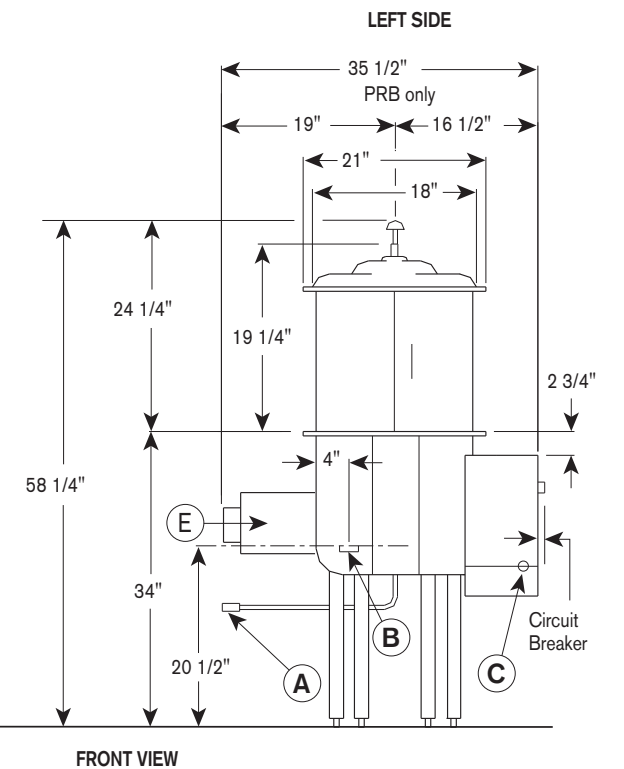
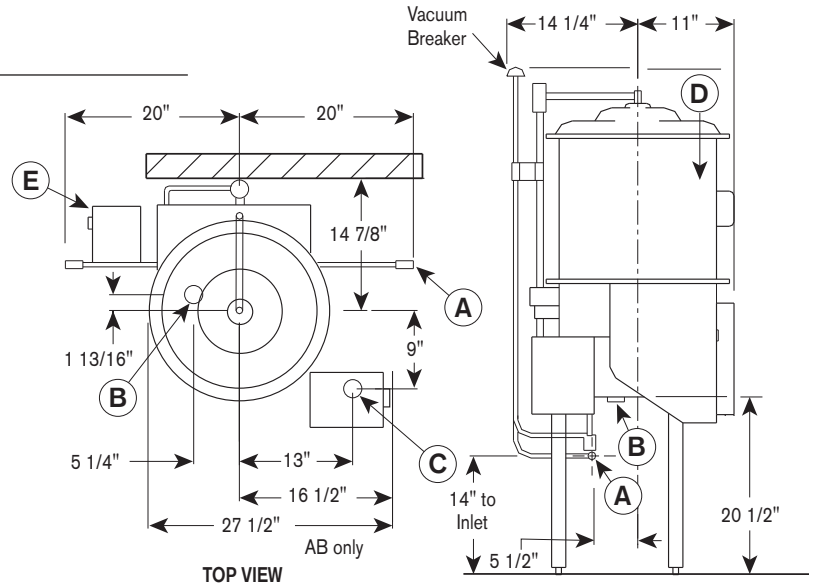

### Approximate Total Load

#### LEGEND:

- A** – Water inlet – 1/2" IPS, plumbing can be directed either right to left
- B** – Drain – 1 1/2" IPS
- C** – Electrical connection. (See table)
- D** – Clearance for dishes – 14"
- E** – Power rinse pump motor (Model 10APRB only)

All dimensions in inches.

All vertical dimensions are +/- 1/2" from floor due to adjustable bullet feet.

Model	Volts	Phase	Amps
10A	208	1	8.0
10A	220	1	8.2
10AB	208	1	38.8
10AB	220	1	37.2
10AB	208	3	25.6
10AB	220	3	24.6
10APRB	208	1	43.4
10APRB	220	1	41.8
10APRB	208	3	30.2
10APRB	220	3	29.2



www.jacksonmsc.com  
1-888-800-5672

