

## Variety Steamer

### Models:

VS-200ADB Double Basket

VS-200ASB Single Basket

VS-350 - Deluxe



VS-200 ADB



VS-350

The Variety Steamer produces steam using plain tap water for quick heating and reconstituting of food items.

Simple push button action delivers an impulse of steam. Because the amount of steam is consistent, it removes the guesswork and produces a uniform finished product from one operator to the next.

Ideal applications include heating pre-cooked portions of pasta, vegetables, rice, shrimp and sliced meat.

### Features:

- Single or Double Basket
- Solid State Controls
- Direct Water Hook-up Kit Supplied
- Stainless Steel Construction

## Dimensions

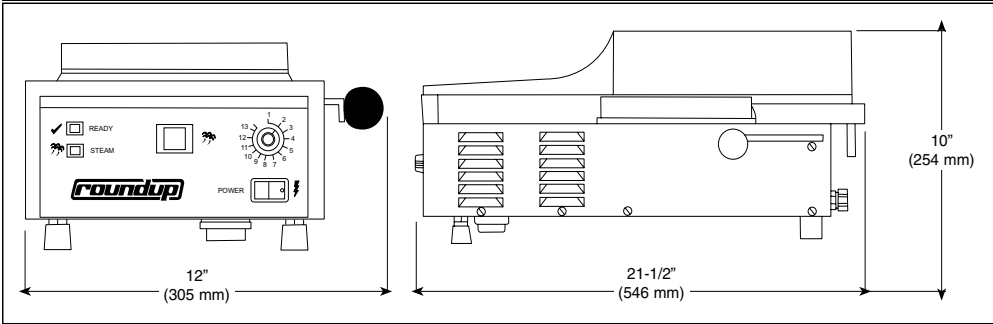

**VS-200**

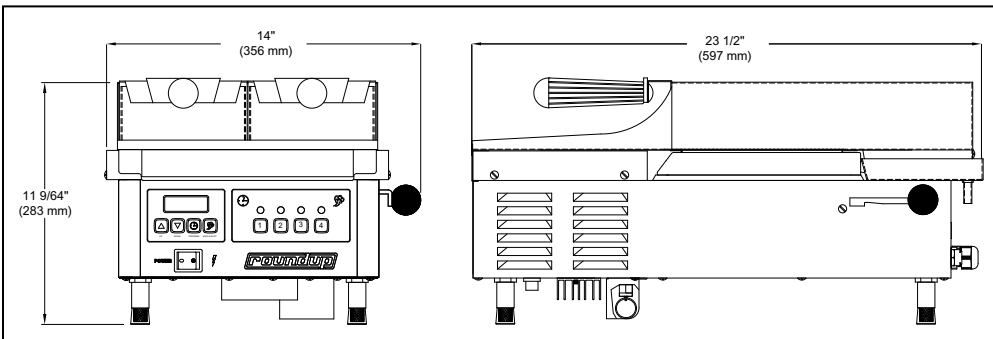

**VS-350**

## Capacities

### VS-200ADB

- 10 oz. of frozen or thawed product in each of two baskets.  
 Note: Pasta must be precooked.

### VS-200ASB

- 20 oz. of frozen or thawed product in one basket.  
 Note: Pasta must be precooked.

### VS-350

- 40 oz. of frozen or thawed product in one basket.  
 Note: Pasta must be precooked.

## Shipping Weight

VS-200	46lbs (21 Kg)
VS-350	64lbs (29 Kg)

## Electrical Cord & Plug Configurations

Letter Code*	Description	Configuration
<b>C</b> <b>R</b> <b>H</b>	Commercial Cord Rockbestos Cord Harmonized Cord	
<b>** (H) C</b>	CEE 7/7, 16 Amp., 250 VAC (Assembly Only).	
<b>** (H) I</b>	IEC-309, 16 Amp., 250 VAC, Pin & Sleeve (Assembly Only)	
<b>*** (C) V</b>	6-20P, 20 Amp., 250 VAC, Non-Locking (Assembly Only)	
<b>S</b>	L6-30P, 30 Amp., 250 VAC, Straight Twist Lock.	

\* Used in Model Designation  
 \*\* Indicates that the plug comes with a Harmonized Cord.  
 \*\*\* Indicates that the plug comes with a Commercial Cord.

## Electrical Ratings - VS-200 ADB

Manufacturing No.	VAC	Watts	Amps	Hz
9100220	208	2850	13.7	50/60
9100222	230	3489	15.8	50/60

## Electrical Ratings - VS-200 ASB

9100210	208	2850	13.7	50/60
9100212	230	3489	15.8	50/60

## Electrical Ratings - VS-350

Manufacturing No.	VAC	Watts	Amps	Hz
9100700	208	5000	24	50/60
9100710	200-240	4575-5444	20.8-22.7	50/60
9100720	220-240	3200-3810	14.5-15.9	50/60