

**Steamer Display Cabinet
Model: SDC-500**

**New
Product
Development!**



The Roundup SDC-500 Steamer Display Cabinet is designed to quickly steam pre-cooked refrigerated or frozen food products and maintain them at ready-to-eat temperatures.

The unit is lit from the top to attractively display food items to your customers.

A resettable hi-limit thermostat is included for additional safety. The SDC-500 also uses an adjustable digital thermostat to allow easy temperature setting.

FEATURES:

- Uses Plain Tap Water.
- Adjustable Shelf Height and Shelf Angle.
- 5 Sliding Shelves Allow Easy Access to Product.
- Adjustable Solid State Thermostat with digital display.
- Resettable Hi-limit Thermostat turns off power to the Heater and Upper Lighting.
- Tempered Safety Glass.
- Stainless Steel Construction for Long Life.
- Easy to fill water pan.
- Unique Water Tube allows for easy monitoring of water level and can be used for quick re-filling or draining of unit.



Dimensions

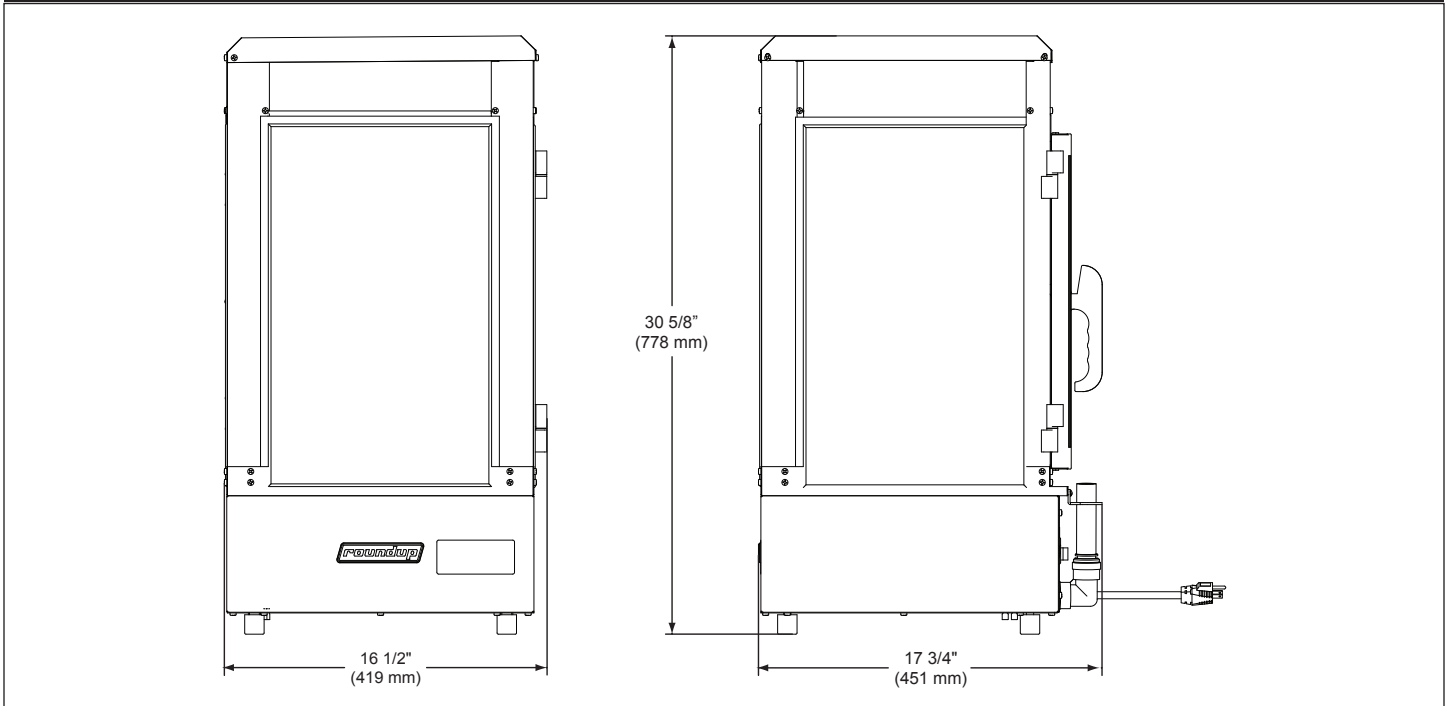

Dimensions

Model & Mfg. No	Width	Depth	Height	Shipping Weight	Operating Weight
SDC-500 9100532	16.50" (419 mm)	17.75" (451 mm)	30.62" (778 mm)	76 lbs. (34 kg)	66 lbs. (30 kg)

Electrical Specifications & Plug Configurations

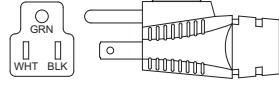
Model & Mfg. No	Voltage	Watts	Amps	Hz	Plug Description	Plug Configuration
SDC-500 9100532	120	1750	14.6	50/60	NEMA 5-15P 15 Amp., 120 VAC., Non-locking (Assembly only)	

Capacities

WATER

Five (5) quarts (4.73 liters) in water tray.
(1.5 quarts or 1.42 liters minimum)

FOOD

Refrigerated or Frozen Product Only

Temperature Ranges

150°F - 180°F (65.5°C - 82°C)