



Our main ingredient is value

SRM60+

MADE IN THE USA

SRM60+

# 60 QT. MIXER

60 QUART FLOOR MODEL

Our SRM60+ Mixer is designed for high volume pizza and institutional operations. For enhanced ease of operation and power efficiency, Univex uses a variable speed transmission that enables the operator to *change speeds without having to first stop the mixer.*

This advanced technology utilizes torque-sensing pulleys to extract a greater torque-to-horsepower ratio with fewer parts. A rugged gear train drives the beater head and PTO shafts.

Standard equipment includes a two-piece, stainless steel removable *Swing Ring™* Safety Guard, a heavy drawn stainless steel bowl, a #12 PTO (Power Take-off). A 15 minute timer and three mixing agitators. Our ALMFC12 Meat & Food Chopper and VS9/VS9H Vegetable Slicer / Grater attachments can be driven by the built-in PTO. An optional power bowl lift is available.

The new and improved 2-piece *Swing Ring™* Safety Guard simply swings apart for accessing the bowl. Its two halves are easily removed for cleaning and fit conveniently in the sink or dishwasher.



- 2-piece *Swing Ring™* Safety Guard opens wide for full access to bowl. Removes easily for cleaning, fits in dishwasher.
- Interlock switches protect operator from injury if Safety Guard is open or bowl is lowered.
- Rugged gear/belt drive system provides durability for tough mixes, and changes speed while mixer is running.
- Heavy-duty stainless steel bowl is standard equipment.
- Equipped with low voltage protection to prevent accidental start-up after power failure.



## OSHA COMPLIANCE

SRM series removable SAFETY GUARDS and interlocking design meet OSHA specifications

29.1910.212 (a)

### WARRANTY

Univex Model SRM60+ Mixer carries a two-year, on-site parts and labor warranty against any flaws in materials and workmanship and a one-year warranty on attachments. This period begins with the date of purchase and, provided the unit is used properly in accordance with our instructions, is in full effect for one year from that date. Any work to be performed under this warranty must be performed between the hours of 8:00 a.m. and 5:00 p.m. local time, Monday through Friday. Univex will not pay overtime charges for work performed other than during normal business hours. Damages incurred in transit or from installation error, accident, alteration or misuse are not covered. Transit damages should be reported to the carrier immediately. Univex shall not be liable for any consequential, compensatory, incidental, or special damages. Contact Univex Service Department for any warranty claims.



UNIVEX CORPORATION ■ 3 Old Rockingham Road ■ Salem, NH 03079-2140  
Tel 603-893-6191 ■ Fax 603-893-1249 ■ E-mail [univex@univexcorp.com](mailto:univex@univexcorp.com)  
TOLL-FREE ORDERING FAX 1-800-356-5614  
[www.univexcorp.com](http://www.univexcorp.com)

April 2005  
Printed in USA

# 60 QT. MIXER

SRM60+

## 60 QUART FLOOR MODEL

\* DENOTES ELECTRICAL CORD LOCATION

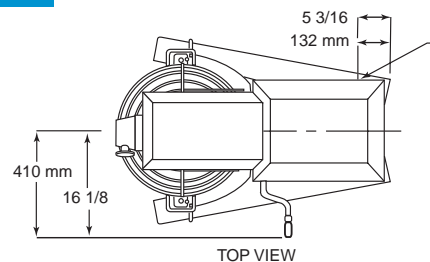
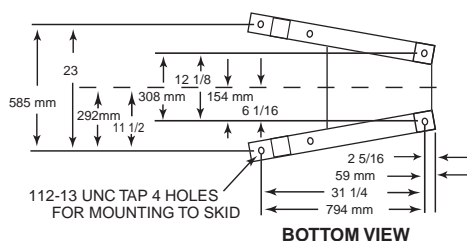
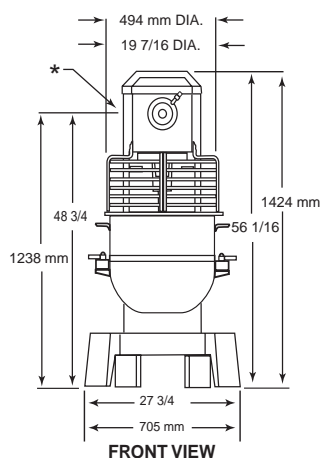

\* DENOTES ELECTRICAL ACCESS

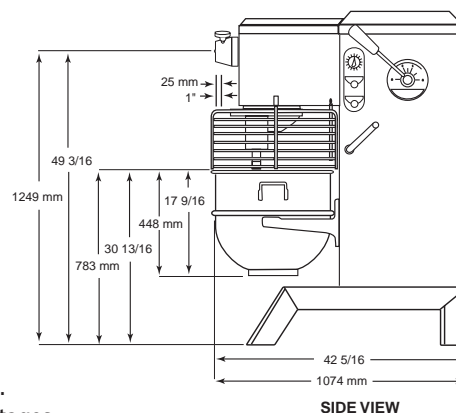

Net Weight: 750 lb. (341 kg)  
 Shipping Weight: 875 lb. (391 kg)  
 Box Dimensions: 65 1/2" (1664 mm) high  
 41 1/4" (1048 mm) wide  
 51" (1295 mm) deep

SRM60+

## SPECIFICATIONS

<b>CAPACITY</b>	72 quarts (68.1 liters)															
<b>MOTOR</b>	3 hp. Capacitor start, 1 phase															
<b>ELECTRICAL</b>	208/240/60 16.8 amps, No cord provided. Consult price list or factory for special voltages															
<b>CONTROLS</b>	Momentary contact STOP and START buttons and contactor. Magnetic starter with overload protection. 15-minute Timer with HOLD.															
<b>TRANSMISSIONS</b>	Univex variable speed transmission with hardened alloy gearing and torque sensing pulleys for reliable performance. Unlike older technology, <i>speed changing is done while mixer is in operation</i> . This drive system is responsive, demand sensitive, and easy-to-service.															
<b>SPEEDS</b>	The Variable Speed transmission not only provides the standard 4 locked-in speeds, but also any in-between speed.															
	<table border="1"> <thead> <tr> <th>SPEED</th> <th>FIRST</th> <th>SECOND</th> <th>THIRD</th> <th>FORTH</th> </tr> </thead> <tbody> <tr> <td>BEATER SHAFT(rpm)</td> <td>75</td> <td>100</td> <td>175</td> <td>340</td> </tr> <tr> <td>PTO(rpm)</td> <td>87</td> <td>115</td> <td>202</td> <td>393</td> </tr> </tbody> </table>	SPEED	FIRST	SECOND	THIRD	FORTH	BEATER SHAFT(rpm)	75	100	175	340	PTO(rpm)	87	115	202	393
SPEED	FIRST	SECOND	THIRD	FORTH												
BEATER SHAFT(rpm)	75	100	175	340												
PTO(rpm)	87	115	202	393												
<b>LUBRICATION</b>	Gearing oil bath															
<b>FINISH</b>	NSF approved resin acrylic enamel															
<b>BOWL</b>	Die-drawn stainless steel with sanitary rim															
<b>STANDARD EQUIPMENT</b>	Stainless Steel 60-Quart Bowl • Batter Beater • Wire Whip • Dough Hook • all stainless removable 2-piece <i>Swing Ring™</i> Safety Guard • #12 Power Take-Off Hub • 15 minute timer															

## AVAILABLE OPTIONS

<b>EQUIPMENT</b>	Power Bowl Lift, Bowl Scraper
<b>ACCESSORIES</b>	Sweet Dough Beater • Pastry Knife • Four-Wing Beater • Bowl Dolly • 30-Quart Bowl & 30-Quart Size Agitators • 30-Quart Bowl Dolly • 30-Quart Bowl Adapter • Splash Extension Ring for 60- & 30-Quart Bowls
<b>ATTACHMENTS</b>	ALMFC12 Meat & Food Chopper • VS9/VS9H Vegetable Slicer/Grater



UNIVEX CORPORATION ■ 3 Old Rockingham Road ■ Salem, NH 03079-2140  
 Tel 603-893-6191 ■ Fax 603-893-1249 ■ E-mail univex@univexcorp.com  
 TOLL-FREE ORDERING FAX 1-800-356-5614  
[www.univexcorp.com](http://www.univexcorp.com)

April 2005  
 Printed in USA