



Our main ingredient is value

SRM30+

MADE IN THE USA

SRM30+

30 QT. MIXER

30 QUART FLOOR MODEL

Our SRM30+ Mixer is designed to handle the heavy use conditions of high volume, small batch pizza chains, as well as full menu operations. Like all Univex Mixers, the SRM30+ uses a power efficient, variable speed transmission that enables the operator to *change speeds without having to first stop the mixer*. This advanced technology utilizes torque-sensing pulleys to extract a greater torque-to-horsepower ratio with fewer parts. A rugged gear train drives the beaterhead and PTO shafts.

Standard equipment on the SRM30+ MIXER includes a two-piece, stainless steel removable *Swing Ring™* Safety Guard, a heavy drawn stainless steel bowl, a #12 PTO (Power Take-off). A 15 minute timer and three mixing agitators. Our ALMFC12 Meat & Food Chopper and VS9/VS9H Vegetable Slicer/Grater attachments can be driven by the built-in PTO.

The new and improved 2-piece *Swing Ring™* Safety Guard simply swings apart for accessing the bowl. Its two halves are easily removed for cleaning and fit conveniently in the sink or dishwasher.



- 2-piece *Swing Ring™* Safety Guard opens wide for full access to bowl. Removes easily for cleaning, fits in dishwasher.
- Interlock switches protect operator from injury if Safety Guard is open or bowl is lowered.
- Rugged gear/belt drive system provides durability for tough mixes, and changes speed while mixer is running.
- Heavy-duty stainless steel bowl is standard equipment.
- Equipped with low voltage protection to prevent accidental start-up after power failure.



OSHA COMPLIANCE

SRM series removable SAFETY GUARDS and interlocking design meet OSHA specifications

29.1910.212 (a)

WARRANTY

Univex Model SRM30+ Mixer carries a two-year, on-site parts and labor warranty against any flaws in materials and workmanship and a one-year warranty on attachments. This period begins with the date of purchase and, provided the unit is used properly in accordance with our instructions, is in full effect for one year from that date. Any work to be performed under this warranty must be performed between the hours of 8:00 a.m. and 5:00 p.m. local time, Monday through Friday. Univex will not pay overtime charges for work performed other than during normal business hours. Damages incurred in transit or from installation error, accident, alteration or misuse are not covered. Transit damages should be reported to the carrier immediately. Univex shall not be liable for any consequential, compensatory, incidental, or special damages. Contact Univex Service Department for any warranty claims.



UNIVEX CORPORATION ■ 3 Old Rockingham Road ■ Salem, NH 03079-2140
Tel 603-893-6191 ■ Fax 603-893-1249 ■ E-mail univex@univexcorp.com
TOLL-FREE ORDERING FAX 1-800-356-5614
www.univexcorp.com

April 2005
Printed in USA

30 QT. MIXER

SRM30+

30 QUART FLOOR MODELS

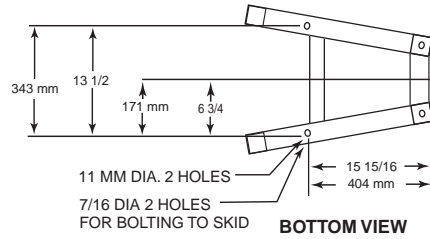
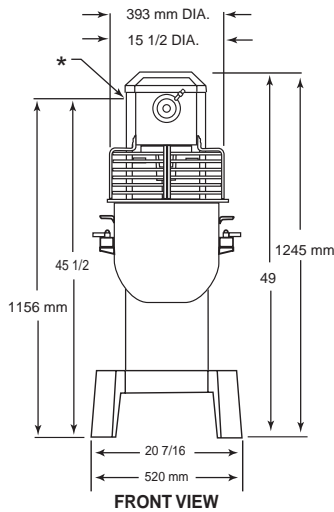

Net Weight: 330 lb. (150 kg)
 Shipping Weight: 360 lb. (163 kg)
 Box Dimensions: 53" (1346 mm) high
 37" (940 mm) wide
 23" (584 mm) deep

* DENOTES ELECTRICAL CORD LOCATION

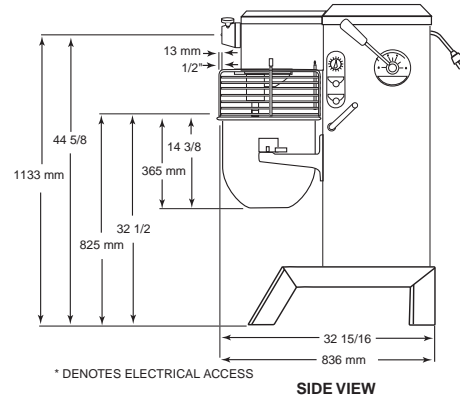
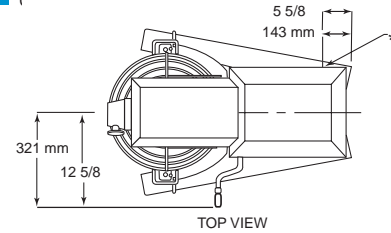

* DENOTES ELECTRICAL ACCESS

SRM30+

SPECIFICATIONS

- CAPACITY:** 36 quarts (34 liters)
- MOTOR:** 1 hp. Capacitor start
- ELECTRICAL:** 115/60/1 13.6 amps, NEMA plug 5-15P.
 Consult price list or factory for special voltages
- CONTROLS:** Momentary contact STOP and START buttons and contactor. Magnetic starter with overload protection. 15-minute Timer with HOLD.
- TRANSMISSIONS:** Univex variable speed transmission with hardened alloy gearing and torque sensing pulleys for reliable performance. Unlike older technology, *speed changing is done while mixer is in operation*. This drive system is responsive, demand sensitive, and easy-to-service.
- SPEEDS:** The Variable Speed transmission not only provides the standard 4 locked-in speeds, but also any in-between speed.

SPEED	FIRST	SECOND	THIRD	FORTH
BEATER SHAFT(rpm)	80	175	305	370
PTO(rpm)	65	140	245	300

- LUBRICATION:** Food grade grease
- FINISH:** NSF approved hybrid epoxy/polyester powder coating
- BOWL:** Die-drawn stainless steel with sanitary rim
- STANDARD EQUIPMENT:** Stainless Steel Bowl • Batter Beater • Wire Whip • all stainless removable 2-piece *Swing Ring™* Safety Guard • #12 Power Take-Off Hub • 15 minute timer

AVAILABLE OPTIONS

- EQUIPMENT :** Bowl Scraper
- ACCESSORIES :** Sweet Dough Beater • Pastry Knife • Four-Wing Beater • 20-Quart Bowl & 20-Quart Size Agitators
- ATTACHMENTS:** ALMFC12 Meat & Food Chopper • VS9/VS9H Vegetable Slicer/Grater



UNIVEX CORPORATION ■ 3 Old Rockingham Road ■ Salem, NH 03079-2140
 Tel 603-893-6191 ■ Fax 603-893-1249 ■ E-mail univex@univexcorp.com
 TOLL-FREE ORDERING FAX 1-800-356-5614
www.univexcorp.com

April 2005
 Printed in USA