



Our main ingredient is value

SRM20

MADE IN THE USA

SRM20

# 20 QT. MIXER

20-QUART COUNTER MODEL

Our SRM20 Counter Mixer satisfies the needs of more foodservice operations than all of our other mixers combined. For enhanced ease of operation and power efficiency, Univex uses a variable speed transmission that enables the operator to *change speeds without having to first stop the mixer*. This advanced technology utilizes torque-sensing pulleys to extract a greater torque-to-horsepower ratio with fewer parts. A rugged gear train drives the beat-head and PTO shafts.

Standard equipment on the SRM20 MIXER includes a two-piece, stainless steel removable *Swing Ring™* Safety Guard, a heavy drawn stainless steel bowl, batter beater, wire whip and a #12 PTO (Power Take-off). Our ALMFC12 Meat & Food Chopper and VS9/VS9H Vegetable Slicer/ Grater attachments can be driven by the built-in PTO.

The new and improved 2-piece *Swing Ring™* Safety Guard simply swings apart for accessing the bowl. Its two halves are easily removed for cleaning and fit conveniently in the sink or dishwasher.



- 2-piece *Swing Ring™* Safety Guard opens wide for full access to bowl. Removes easily for cleaning, fits in dishwasher.
- Interlock switches protect operator from injury if Safety Guard is open or bowl is lowered.
- Rugged gear/belt drive system provides durability for tough mixes, and changes speed while mixer is running
- Heavy-duty stainless steel bowl is standard equipment
- Equipped with low voltage protection to prevent accidental start-up after power failure

### OSHA COMPLIANCE

SRM series removable SAFETY GUARDS and interlocking design meet OSHA specifications

29.1910.212 (a)



### WARRANTY

Univex Model SRM20 Mixer carries a two-year, on-site parts and labor warranty against any flaws in materials and workmanship and a one-year warranty on attachments. This period begins with the date of purchase and, provided the unit is used properly in accordance with our instructions, is in full effect for one year from that date. Any work to be performed under this warranty must be performed between the hours of 8:00 a.m. and 5:00 p.m. local time, Monday through Friday. Univex will not pay overtime charges for work performed other than during normal business hours. Damages incurred in transit or from installation error, accident, alteration or misuse are not covered. Transit damages should be reported to the carrier immediately. Univex shall not be liable for any consequential, compensatory, incidental, or special damages. Contact Univex Service Department for any warranty claims.



UNIVEX CORPORATION ■ 3 Old Rockingham Road ■ Salem, NH 03079-2140  
Tel 603-893-6191 ■ Fax 603-893-1249 ■ E-mail [univex@univexcorp.com](mailto:univex@univexcorp.com)  
TOLL-FREE ORDERING FAX 1-800-356-5614  
[www.univexcorp.com](http://www.univexcorp.com)

April 2005  
Printed in USA

# 20 QT. MIXER

SRM20

SRM20

## 20-QUART COUNTER MODEL

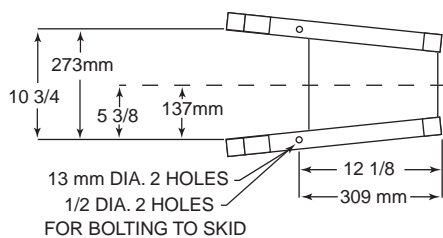
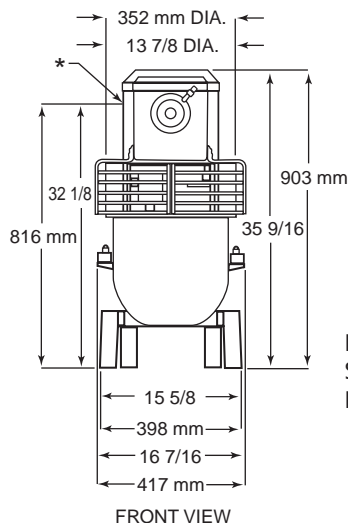

BOTTOM VIEW

Net Weight: 215 lb. (97 kg)  
 Shipping Weight: 260 lb. (118 kg)  
 Box Dimensions: 41" (1041 mm) high  
 36 1/2" (927 mm) wide  
 23" (584 mm) deep

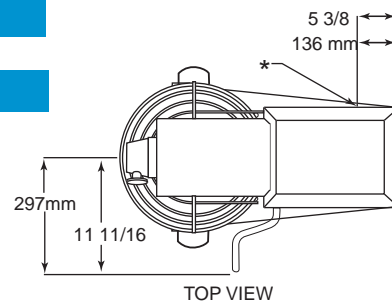

TOP VIEW

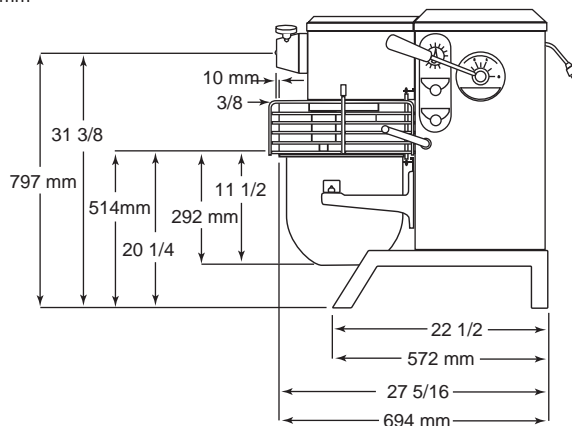

SIDE VIEW

## SPECIFICATIONS

- CAPACITY** 22 quarts (20.8 liters)
- MOTOR** 1/2 hp. Capacitor start
- ELECTRICAL** 115/60/1 9.4 amps, NEMA plug 5-15P.
- CONTROLS** Momentary contact STOP and START buttons and contactor.
- TRANSMISSIONS** Univex variable speed transmission with hardened alloy gearing and torque sensing pulleys for reliable performance. Unlike older technology, *speed changing is done while mixer is in operation.* This drive system is responsive, demand sensitive, and easy-to-service.
- SPEEDS** The Variable Speed transmission not only provides the standard 4 locked-in speeds, but also any in-between speed.

SPEED	FIRST	SECOND	THIRD	FORTH
BEATER SHAFT(rpm)	90	190	305	365
PTO(rpm)	60	125	200	240

- LUBRICATION** Food grade grease
- FINISH** NSF approved hybrid epoxy/polyester powder coating
- BOWL** Die-drawn stainless steel with sanitary rim
- STANDARD EQUIPMENT** Stainless Steel Bowl • Batter Beater • Wire Whip • all stainless removable 2-piece *Swing Ring™* Safety Guard

## AVAILABLE OPTIONS

- EQUIPMENT** Timer (Also available without #PTO at reduced cost), Bowl Scraper
- ACCESSORIES** Dough Hook • Sweet Dough Beater • Pastry Knife • Four-Wing Beater • 12-Quart Bowl & 12-Quart Size Agitators
- ATTACHMENTS** ALMFC12 Meat & Food Chopper • VS9/VS9H Vegetable Slicer/Grater



UNIVEX CORPORATION ■ 3 Old Rockingham Road ■ Salem, NH 03079-2140  
 Tel 603-893-6191 ■ Fax 603-893-1249 ■ E-mail univex@univexcorp.com  
 TOLL-FREE ORDERING FAX 1-800-356-5614  
[www.univexcorp.com](http://www.univexcorp.com)

April 2005  
 Printed in USA