



Our main ingredient is value

SRM12

MADE IN THE USA

SRM12

12 QT. MIXER

12-QUART COUNTER MODEL

FIRST IN THE US TO INTRODUCE BOWL SAFETY RING AS STANDARD EQUIPMENT

Our SRM12 Mixer is the smallest commercial grade mixer available with a #12 PTO (Power Take-Off) as standard equipment. Like all Univex Mixers, the SRM12 uses a power-efficient, variable speed transmission that enables the operator to *change speeds without having to first stop the mixer*. This advanced technology utilizes torque-sensing pulleys to extract a greater torque-to-horsepower ratio with fewer parts. A rugged gear train drives the beater head and PTO shafts.

Standard equipment includes a two piece, stainless steel removable *Swing Ring™* Safety Guard, a heavy drawn stainless steel bowl, batter beater, wire whip and the #12 PTO. Our ALMFC12 Meat & Food Chopper and VS9/VS9H Vegetable Slicer/Grater attachments can be driven by the built-in PTO. A complete line of accessories is available for batch or specialty mixing.

The new and improved 2-piece *Swing Ring™* Safety Guard simply swings apart for accessing the bowl. Its two halves are easily removed for cleaning and fit conveniently in the sink or dishwasher.



- 2-piece *Swing Ring™* Safety Guard opens wide for full access to bowl. Removes easily for cleaning, fits in dishwasher.
- Interlock switches protect operator from injury if Safety Guard is open or bowl is lowered.
- Rugged gear/belt drive system provides durability for tough mixes, and changes speed while mixer is running.
- Heavy-duty stainless steel bowl is standard equipment.
- Equipped with low voltage protection to prevent accidental start-up after power failure.



OSHA COMPLIANCE

SRM series removable SAFETY GUARDS and interlocking design meet OSHA specifications

29.1910.212 (a)

WARRANTY

Univex Model SRM12 Mixer carries a two-year, on-site parts and labor warranty against any flaws in materials and workmanship and a one-year warranty on attachments. This period begins with the date of purchase and, provided the unit is used properly in accordance with our instructions, is in full effect for one year from that date. Any work to be performed under this warranty must be performed between the hours of 8:00 a.m. and 5:00 p.m. local time, Monday through Friday. Univex will not pay overtime charges for work performed other than during normal business hours. Damages incurred in transit or from installation error, accident, alteration or misuse are not covered. Transit damages should be reported to the carrier immediately. Univex shall not be liable for any consequential, compensatory, incidental, or special damages. Contact Univex Service Department for any warranty claims.



UNIVEX CORPORATION ■ 3 Old Rockingham Road ■ Salem, NH 03079-2140
Tel 603-893-6191 ■ Fax 603-893-1249 ■ E-mail univex@univexcorp.com
TOLL-FREE ORDERING FAX 1-800-356-5614
www.univexcorp.com

April 2005
Printed in USA

12 QT. MIXER

SRM12

12-QUART COUNTER MODEL

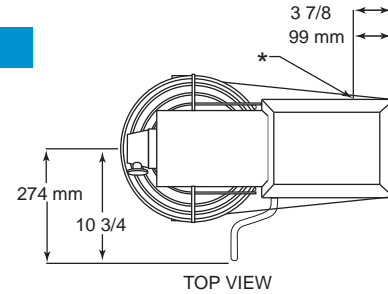
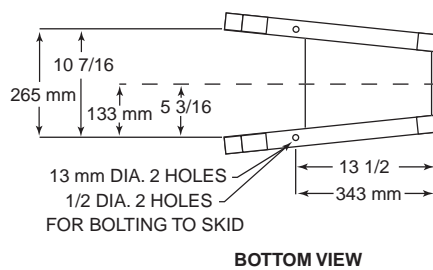
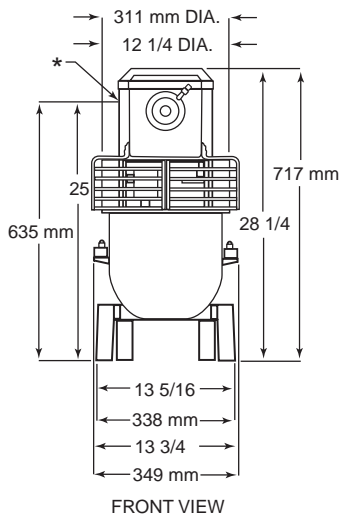

* DENOTES ELECTRICAL CORD LOCATION

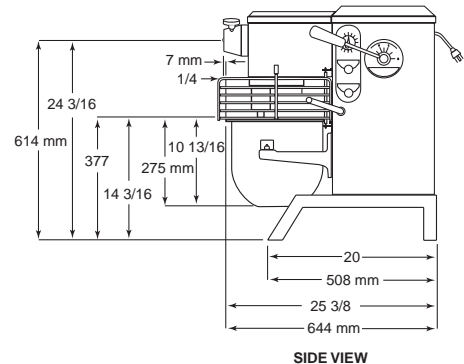

Net Weight: 146 lb. (66 kg)
 Shipping Weight: 170 lb. (77 kg)
 Box Dimensions: 34" (864 mm) high
 30 1/2" (775 mm) wide
 20 1/2" (521 mm) deep

SRM12

SPECIFICATIONS

- CAPACITY:** 15 quarts (14.2 liters)
- MOTOR:** 1/3 hp.
- ELECTRICAL:** 115/60/1 6.2 amps, NEMA plug 5-15P.
 Consult price list or factory for special voltages
- CONTROLS:** Momentary contact STOP and START buttons and contactor.
- TRANSMISSIONS:** Univex variable speed transmission with hardened alloy gearing and torque sensing pulleys for reliable performance. Unlike older technology, *speed changing is done while mixer is in operation*. This drive system is responsive, demand sensitive, and easy-to-service.
- SPEEDS:** The Variable Speed transmission not only provides the standard 4 locked-in speeds, but also any in-between speed.

SPEED	FIRST	SECOND	THIRD	FOURTH
BEATER SHAFT(rpm)	125	180	240	300
PTO(rpm)	145	200	270	345

- LUBRICATION:** Food grade grease
- FINISH:** NSF automotive resin acrylic enamel
- BOWL:** Die-drawn stainless steel with sanitary rim
- STANDARD EQUIPMENT:** Stainless Steel Bowl • Batter Beater • Wire Whip • All stainless removable 2-piece *Swing Ring*™ Safety Guard

AVAILABLE OPTIONS

- EQUIPMENT:** Timer (also available without #12 PTO at reduced cost)
- ACCESSORIES:** Dough Hook • Sweet Dough Beater • Pastry Knife • Four-wing Beater
- ATTACHMENTS:** ALMFC12 Meat & Food Chopper • VS9/VS9H Vegetable Slicer/Grater



UNIVEX CORPORATION ■ 3 Old Rockingham Road ■ Salem, NH 03079-2140
 Tel 603-893-6191 ■ Fax 603-893-1249 ■ E-mail univex@univexcorp.com
 TOLL-FREE ORDERING FAX 1-800-356-5614
www.univexcorp.com

April 2005
 Printed in USA