



Our main ingredient is value

M40, M60, M80, M100

SPIRAL DOUGH MIXERS

FOR BAKERY OPERATIONS

SMALL TO MID-SIZE MODELS WITH FIXED BOWLS

Outstanding engineering and quiet operation make Univex M Series mixers an excellent choice for the large volume dough producer. Precision tolerances between the spiral arm, bowl and kneading column allow highly efficient blending of ingredients in short working times. Two speeds are standard, but single-speed models are also available for pizza and bagel production.

Choose manual, semi-automatic or automatic operation using the simple controls. Electronic timers can be set for both speeds. Automatic shifting into second speed frees up operator time. Rotation of the bowl can also be set to reverse during the automatic cycle. For unloading, the convenient pulse feature turns the bowl incrementally with the guard up. Electrical interlocks prevent accidental mixer operation.

The powerful belt drive provides low-vibration, low-noise performance and economical maintenance, for years of reliable service. And, despite their weight, M Series mixers are easy to move and position, thanks to built-in casters and leveling feet.

The M100 and larger models are available equipped with power tilting lifts for both table and divider heights. Contact Factory for information.



- Up to 220 lbs. dough capacity – up to 130 lbs. flour capacity!
- Heavy-duty engineering – handles tough doughs
- Automatic, semi-automatic or manual mode
- Electronic timers automatically shift from 1st to 2nd speed
- Low maintenance costs
- Integral bowl safety guard
- Bi-directional bowl rotation
- Bowl pulse
- Moves easily on casters
- Models available with tilt lifts for table or divider height

WARRANTY

Univex M Series Spiral Dough Mixers carry a one-year, on-site parts and labor warranty against any flaws in materials and workmanship. This period begins with the date of purchase and, provided the unit is used properly in accordance with our instructions, is in full effect for one year from that date. Any work to be performed under this warranty must be performed between the hours of 8:00 a.m. and 5:00 p.m. local time, Monday through Friday. Univex will not pay overtime charges for work performed other than during normal business hours. Damages incurred in transit or from installation error, accident, alteration or misuse are not covered. Transit damages should be reported to the carrier immediately. Univex shall not be liable for any consequential, compensatory, incidental, or special damages. Contact Univex Service Department for any warranty claims.



UNIVEX CORPORATION ■ 3 Old Rockingham Road ■ Salem, NH 03079-2140

Tel 603-893-6191 ■ Fax 603-893-1249 ■ E-mail univex@univexcorp.com

TOLL-FREE ORDERING FAX 1-800-356-5614

www.univexcorp.com

April 2005
Printed in USA

M40, M60, M80, M100

SPIRAL DOUGH MIXERS

FOR BAKERY OPERATIONS

M40, M60, M80, M100

SMALL TO MID-SIZE MODELS WITH FIXED BOWLS

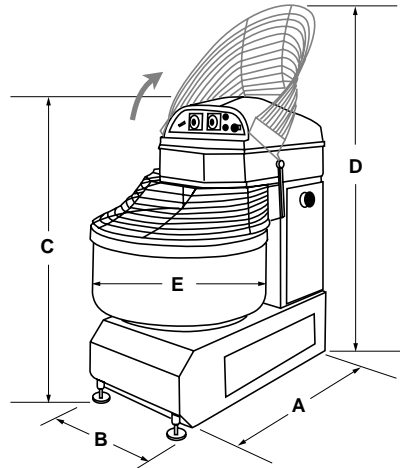

M40, M60, M80, M100

	M40	M60	M80	M100
A DEPTH	41 1/2" (105 cm)	43 1/2" (110 cm)	48" (122 cm)	48" (122 cm)
B WIDTH	22 1/2" (57 cm)	24" (61 cm)	28 3/4" (73 cm)	28 3/4" (73 cm)
C HEIGHT	44" (112 cm)	47" (119 cm)	55 1/2" (141 cm)	55 1/2" (141 cm)
D OPEN HEIGHT	59" (150 cm)	63" (160 cm)	74 1/2" (189 cm)	74 1/2" (189 cm)
E BOWL DIA.	21" (53 cm)	23" (58 cm)	27 3/4" (70 cm)	27 3/4" (70 cm)
NET WEIGHT	552 lbs. (250 kg)	728 lbs. (330 kg)	1103 lbs. (500 kg)	1114 lbs. (505 kg)
SHIPPING WEIGHT	640 lbs. (290 kg)	816 lbs. (370 kg)	1235 lbs. (560 kg)	1246 lbs. (565 kg)
CRATE depth	49 1/4" (125 cm)	49 1/4" (125 cm)	55 1/4" (140 cm)	55 1/4" (140 cm)
width	29 3/4" (75 cm)	29 3/4" (75 cm)	35 1/2" (90 cm)	35 1/2" (90 cm)
height	55 1/4" (140 cm)	55 1/4" (140 cm)	63" (160 cm)	63" (160 cm)
CUBIC MEASURE	46 ft ³ (1.3 m ³)	46 ft ³ (1.3 m ³)	71 ft ³ (2.0 m ³)	71 ft ³ (2.0 m ³)

SPECIFICATIONS

CAPACITIES	Model	M40	M60	M80	M100
	Dough	90 lbs. (40 kg)	130 lbs. (60 kg)	175 lbs. (80 kg)	220 lbs. (100 kg)
	Flour	55 lbs. (25 kg)	80 lbs. (37 kg)	110 lbs. (50 kg)	130 lbs. (60 kg)
	Bowl	74 qts. (70 ltr)	100 qts. (95 ltr)	150 qts. (142 ltr)	166 qts. (157 ltr)
MOTORS					
	Spiral Arm Motor				
	Speeds* 1/2 (rpm)	100/200	100/200	100/200	100/200
	HP	1.7/3.6	2.4/4.8	6.0/8.3	6.0/8.3
	AMP Draw (208V)	10.3/12.4	11.5/14.5	22.4/26.5	22.4/26.5
	AMP Draw (220V)	9.8/11.7	10.9/13.7	20.9/25.0	20.9/25.0
	Bowl Motor (rpm)	15-16	15-16	15-16	15-16
	HP	0.3	0.6	1.0	1.0
	AMP Draw (208V)	2.3	3.4	6.3	6.3
	AMP Draw (220V)	2.1	3.2	6.0	6.0

*Optional single-speed models available for bagel and pizza operations. Contact Factory for information.

- ELECTRICAL** 208/60/3-phase, 220/60/3-phase, or 460/60/3-phase. Low voltage electrical interlocks prevent mixer operation without bowl guard in place. No cord provided. Contact Factory for special voltages.
- CONTROLS** Main Power switch. Momentary contact STOP and START buttons. Electronic timers for 1st and 2nd speeds. Bi-directional bowl rotation. Bowl pulse with guard raised.
- DRIVE SYSTEM** Multi-belt spiral arm drive for quiet, low-vibration operation and low-cost maintenance.
- CONSTRUCTION** Powder-coated steel body. Stainless steel bowl, spiral arm and bowl guard. Leveling feet, plus built-in casters for easy movement.
- TILT LIFT OPTIONS** Consult Factory for information on the M100 and larger models equipped with hydraulic powered tilting lifts, available in table and divider heights.



UNIVEX CORPORATION ■ 3 Old Rockingham Road ■ Salem, NH 03079-2140
 Tel 603-893-6191 ■ Fax 603-893-1249 ■ E-mail univex@univexcorp.com
 TOLL-FREE ORDERING FAX 1-800-356-5614
www.univexcorp.com

April 2005
 Printed in USA