

DUKE®

613Q-G3 CONVECTION OVEN



CATALOG NO. 9526

with 50/50 independent doors

single section - deep depth

OVERALL DIMENSIONS:

Height: 60", includes 27" legs

Width: 38"

Depth: 43-1/2"

Cavity Dimensions: 29"W x 24"H x 28"D

STANDARD FEATURES:

Stainless steel front, sides and top. 20% larger interior cavity than industry standard, 13 rack positions with 1-11/16" spacing, 6 racks supplied as standard, porcelainized interior finish with 7/8" covered corners, simultaneously opening doors and 27" angular painted legs with adjustable feet. Two speed blower motor.

OVEN SECTIONS:

Stainless steel front, sides and top. 50/50 stainless steel doors with double pane glass in both doors. Stainless steel interior door liners and door gaskets. Doors mounted on full length solid steel shafts and bronze bushings. Interior lighting (2, 50 watt, 115v bulbs). Bottom, sides and back fully insulated with 1-1/2" thick insulation, top to have 3" thick insulation.

46,000 BTU input, electronic pilot re-light system, 1/2 HP two speed blower motor, 115v, ON-OFF-COOL DOWN switch, manual gas shut-off on control panel.

OTHER OPTIONS:

Solid stainless steel door in lieu of glass, stainless steel interior, stainless steel back panel, 27" stainless steel legs, stainless steel open leg base with rack guides, casters, porcelain drip tray, field stacking kit (8" legs and flue connector), Pulse Fan option ("W" control only), 208/240 volt single phase motor on gas oven, seismic feet, 48" flexible disconnect with restraining device, down draft hood, extra oven racks and extended warranty (2 years parts and labor).

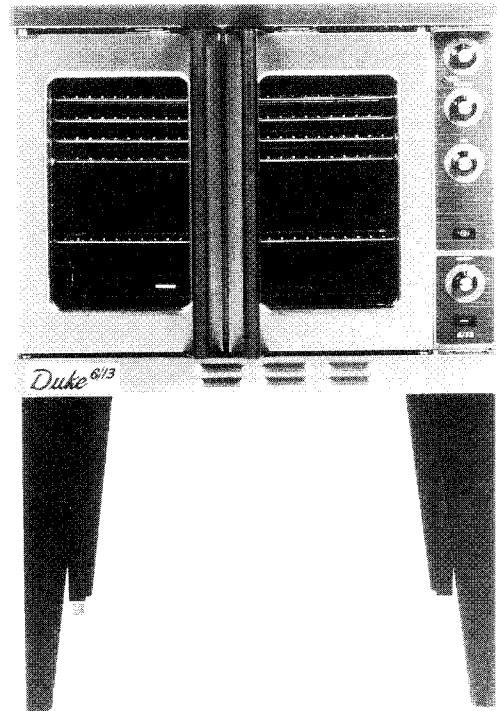

CONTROL OPTIONS: must pick one

"___V" — Basic snap action thermostat (200°-500°F) and 60 minute electric dial timer with continuous sounding buzzer, and 2-speed fan.

"___W" — Solid state digital time and temperature controls, knob adjustable 12 hour countdown timer, and 2-speed fan.

"___X" — **Cook and Hold**, solid state time and temperature, 12 hour countdown timer, and 2-speed fan.

"___Z" — Five programmable menu buttons, knob adjustable solid state digital time and temperature controls, 12 hour countdown timer, **Cook and Hold** feature and 2-speed fan.

"___ZX" — Five programmable buttons, 5-rack ID timers, knob adjustable solid state digital time and temperature controls, 12 hour countdown timer, and 2-speed fan.

"___ZZ" — Sixteen programmable menu buttons, 5 rack ID timers, push button control with solid state digital time and temperature control, manual mode, **Cook and Hold**, Fan Delay Gentle Pulse, 2-speed fan and auxiliary back up thermostat control system.

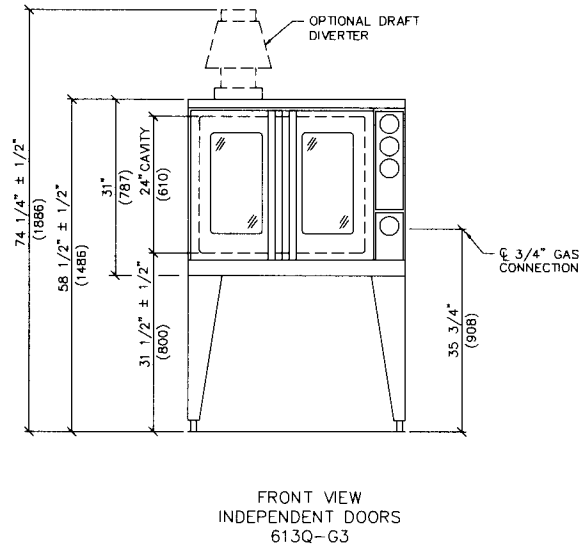
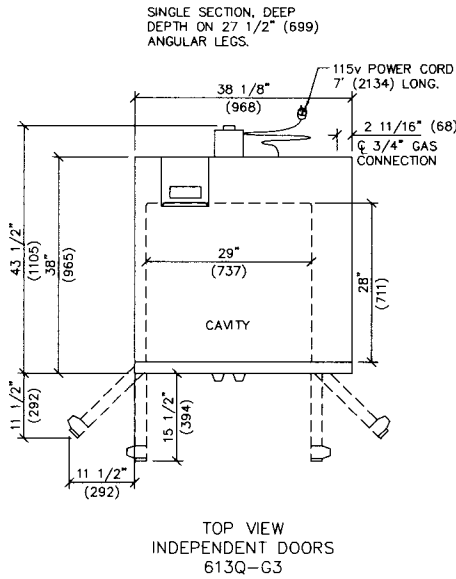

Model	Depth		Width		Height		Cube crated ft.	Weight	
	in.	cm	in.	cm	in.	cm		lbs.	kg
613Q-G3	43-1/2	110.5	38	96.5	60	152.4	56.0	540	245

Model	Total BTU/hr per section	Gas connection per section	Electrical requirements per section	Crated Dimensions per section
613Q-G3	46,000	3/4"	3.5 amps (115v) 2 amps (208/240v)	L - 51" W - 42-1/2" H - 39"

1. Regulated gas pressure required: 3.5" WC natural / 10" WC propane
2. Specify gas type
3. Specify altitude over 2,000 feet
4. Combustible surface clearance: 1" side, 1" rear, 6" floor
5. Standard 115 volt units supplied with 5' cord and plug

OPTIONS:

- | | | |
|---------------------------------|-------------------------------------|--|
| Solid stainless steel door | Casters | 28" flexible disconnect w/restraining device |
| Stainless steel interior | Porcelain drip tray | Down draft hood |
| Stainless steel back panel | Field stacking kit | Extra oven racks |
| 27" stainless steel legs | Pulse Fan option ("W" control only) | Extended warranty |
| S/S open leg base w/rack guides | 208/240 volt single phase motor | |
| | Seismic feet | |