



# FLAV-R-SAVOR® LARGE CAPACITY MERCHANDISING CABINETS

Models WFST-1X, WFST-2X

The Hatco large capacity Flav-R-Savor Heated and Humidified Merchandising Cabinet holds more product at proper serving temperature than standard size models. Prepare food in advance of peak periods and place product straight from the oven into the full-view cabinets to increase impulse sales. Temperatures range from 80° to 190°F (27° to 88°C).

## FLEXIBILITY

Available with a 4-shelf stationary rack, Flav-R-Savor utilizes controlled moisturized heat to create a "blanket" effect around the food to maintain quality and proper serving temperatures.

Model WFST-1X features a chrome-plated 4-shelf multi-purpose stationary wire rack capable of holding standard sheet pans 18" x 26" (457 x 660 mm). This flexible rack allows the operator to customize the Flav-R-Savor to fit multiple foodservice uses with slant or horizontal shelves. The WFST-2X has an additional set of French-style doors on the customer side of the unit for easy pass-thru convenience. Optional self-closing doors are available for self-serve applications.

## QUALITY

The following features assure the finest performance for years to come:

- Controlled moisturized heat creates a "blanket" effect around the food in the WFST models.
- Tempered glass doors and side panels provide maximum heat retention and allow for full cabinet display.
- Maintains proper serving temperature and keeps food moist and tender.
- Shatter-resistant incandescent lights enhance product displays while safeguarding food products from bulb breakage.
- Available in black or clear anodized finish with French-style doors and 6' (1829 mm) cord and plug.
- Optional stacking kit, self-closing sliding or French doors, and custom graphic decals.



WFST-1X with accessory sheet pans



WFST-2X with optional Designer color and sliding doors

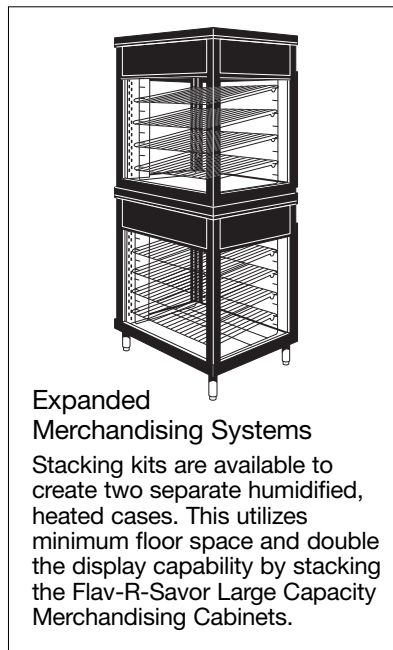

## Expanded Merchandising Systems

Stacking kits are available to create two separate humidified, heated cases. This utilizes minimum floor space and double the display capability by stacking the Flav-R-Savor Large Capacity Merchandising Cabinets.

## Custom Food Decals



Eye-catching food decals for the side panels. Maximum 3 decals per unit.



METAL SHEATHED AIR HEATING ELEMENTS  
GUARANTEED AGAINST BURNOUT AND BREAKAGE  
FOR TWO YEARS.



HATCO CORPORATION P.O. Box 340500 Milwaukee, WI 53234-0500 U.S.A.  
(800) 558-0607 • (414) 671-6350 • Fax (800) 543-7521 • Int'l Fax (414) 671-3976  
www.hatcocorp.com • E-mail: equipsales@hatcocorp.com

Form No. WFST-1006(S)

Printed in U.S.A.



# FLAV-R-SAVOR® LARGE CAPACITY MERCHANDISING CABINETS

Models WFST-1X, WFST-2X

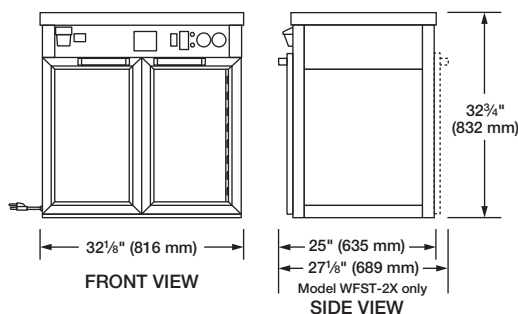

## SPECIFICATIONS

Model	Type	Rack Style	Shipping Weight
WFST-1X	2 Doors	Stationary	163 lbs. (74 kg)
WFST-2X	4 Doors	Stationary	188 lbs. (85 kg)

## WATER QUALITY REQUIREMENTS

Water supply in excess of 3.0 grains of hardness per gallon (GPG) (.75 grains of hardness per liter) must be treated and softened before being used. Water containing over 3.0 GPG (.75 GPL) will decrease the efficiency and reduce the operating life of the unit.

*Note: Product failure caused by liming or sediment buildup is not covered under warranty.*

## Display Racks

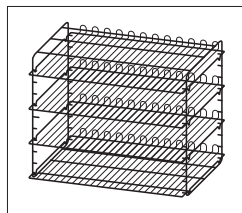

**4-Shelf Multi-Purpose Rack**  
(Holds max. 18" x 26" (457 x 660 mm)  
Full-size Sheet Pans)

## DIMENSIONS

WFST-1X: 32 $\frac{1}{8}$ " W x 25" D x 32 $\frac{3}{4}$ " H (816 x 635 x 832 mm).  
WFST-2X: 32 $\frac{1}{8}$ " W x 27 $\frac{1}{8}$ " D x 32 $\frac{3}{4}$ " H (816 x 689 x 832 mm).  
Cabinet Opening: 28" W x 21 $\frac{7}{8}$ " H (711 x 556 mm).

## VOLTAGE

120 volts, 60 Hz, 1790 watts, 14.9 amps  
(requires NEMA 5-15P, NEMA 5-20P – Canada).  
220 volts, 50/60 Hz, 1750 watts, 8.0 amps  
(uses CEE 7/7 Schuko plug configuration).  
240 volts, 50/60 Hz, 1790 watts, 7.5 amps  
(uses BS-1363 plug configuration).

## CORD LOCATION

Facing controls, left-hand side panel, bottom right corner.

## PLUG CONFIGURATIONS

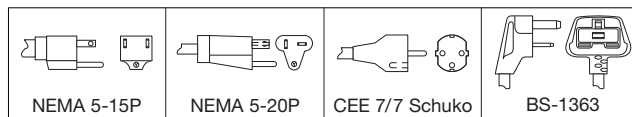

## OPTIONS (NOT FOR RETROFIT)

- Designer Colors: Warm Red, Black, Gray Granite, White Granite, Navy Blue, Hunter Green
- Self-closing Sliding Doors (In lieu of Hinged Doors on one side only for WFST-2X)
- Self-closing French Doors

## ACCESSORIES

- Stacking Kit in Gray or Black (Includes 6" (152 mm) Stainless Steel Legs, Top and Bottom Frame)
- 4" (102 mm) Adjustable Legs
- Sign Holder (Without acrylic window)
- Custom Food and Graphic Decals (3 per set)  
Chicken, Ribs, or Today's Hot Specials
- Full-size Sheet Pans 18" x 26" (457 x 660 mm)
- Half-size Sheet Pans 18" x 13" (457 x 330 mm)

## PRODUCT SPECS

### Holding and Display Cabinet

The humidity controlled Holding and Display Cabinet shall be a Flav-R-Savor® Model ...., rated at ....volts and ....watts, as manufactured by the Hatco Corporation, Milwaukee, WI 53234 U.S.A.

The cabinet shall have ....door(s), tempered glass sides, stationary rack, and incandescent display lights. It shall include

a water reservoir, humidity selector switch, temperature selector dial, on-off switch, indicating lights, and a 6' (1829 mm) cord with plug attached.

Accessories shall include adjustable legs, stacking hardware, pans, merchandising display sign(s), and food graphic decals.